



# PARASOUND

*affordable audio for the critical listener*

## *T/DQ-1600 Broadcast Reference Tuner*

Congratulations on your purchase of this precision audio component and thank you for your selection of Parasound. Your T/DQ-1600 Broadcast Reference Tuner has been designed with the latest technology to perform flawlessly in the finest music systems. Premium parts and advanced design with full remote control make the T/DQ-1600 one of the finest tuner values ever offered. You have made an excellent choice.

Please take a few moments now to read these instructions thoroughly so you may fully understand the sophisticated capabilities of your new tuner.

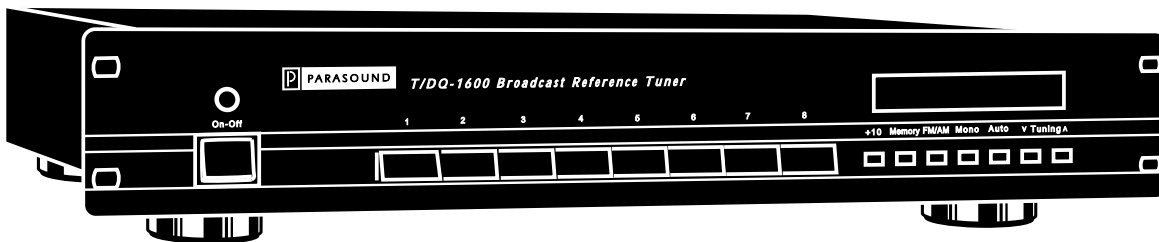

### **Unpacking**

Remove the remote control handset and the AC cord which are packed separately inside the carton. We recommend using only this specially selected cord for the best musical reproduction.

Save your carton and the packing inserts for future safe transport in case you move or the unit requires shipping for repair. Note: the actual printed carton is not itself strong enough for safe shipping; you must place this carton into an additional outer "overcarton" before shipment.

Before you proceed, find the serial number which is located on the rear panel of the unit and note it here for future reference or in case the unit is ever stolen \_\_\_\_\_.

### **Placement of the T/DQ-1600**

Keep your Parasound T/DQ-1600 away from direct sunlight that may interfere with its remote control sensor. It should be placed away from a heat source such as hot air registers or radiators. Do not place the unit directly on a pile carpet that could interfere with air flow into its bottom vent openings. If you stack your components, we suggest you place your T/DQ-1600 below or alongside other components which may generate heat. Additionally, close proximity to some power amplifiers or CD players may interfere with clear radio reception of your T/DQ-1600.

## Connecting Your T/DQ-1600

### Audio Connections

Before making any connections, turn off the power to your preamplifier and power amplifier. This will avoid an accidental "blast" of sound which could damage your speakers.

Connect the cables supplied between the OUTPUT jacks on your T/DQ-1600 and any high level input jacks on your preamplifier or receiver marked TUNER, CD, AUX or TAPE PLAY. Connect the RIGHT and LEFT channels according to their markings on both units. Make certain that all your connections are secure and that there is no tension on the cables which could cause them to pull loose later.

You may prefer to try premium audio interconnect cables which are available from your Parasound dealer. The benefits of these are debated among audio hobbyists, and we cannot guarantee you will always hear an audible improvement that will justify their cost.

You may connect the output of your T/DQ-1600 directly to a power amplifier which has input level controls, however you may require the additional gain of a preamplifier to reach adequate listening levels.

Once the inputs have been connected, plug the AC cord into any convenient outlet or into an outlet on the rear panel of your preamplifier or receiver. Try to run the AC cord in a perpendicular direction to the audio cables to minimize hum.

### FM Antenna Connections

Adequate FM reception and subsequent sound quality is largely dependent upon your choice and location of the antenna. There are several options to consider when selecting an antenna and connecting it to your T/DQ-1600.

#### Dipole Antenna

A standard FM "folded dipole" antenna is included with your T/DQ-1600. The dipole antenna is adequate for most urban and suburban locations and is very easy to install. Simply connect the spade connectors to the screws marked 300  $\Omega$  on the supplied balun adapter and connect the adapter to the round "F" connector on the rear panel of your T/DQ-1600.

#### Outdoor Antenna

For best reception and maximum noise rejection, we recommend the use of a high-quality outdoor FM antenna. Although this requires a little extra effort, the additional stations you can receive and the superior sound quality will be well worthwhile. For best noise rejection, use 75  $\Omega$  cable with an "F" connector and connect the antenna directly to your T/DQ-1600. If you use 300  $\Omega$  twin lead cable, use the balun adapter as described above.

#### Cable Transmission

Many cable companies transmit FM stations and cable TV audio signals along with the cable TV channels. With some cable operators, the quality of the signal can be very good depending on the quality of their transmitter. Connection to your T/DQ-1600 is as simple as connecting a signal splitter to the cable output and connecting a 75  $\Omega$  cable to both your T/DQ-1600 and your television. Check with your local cable company to check for the availability of FM stations in your area and any additional charges for this service.

#### "Powered" Antennas

Small powered indoor antennas are sometimes useful when it is impractical to install an outdoor antenna or when FM transmission is not available. However, they can sometimes add noise and distortion to the RF signal. In most cases, you can receive signals better with the supplied dipole antenna. Use discretion when using these types of antennas.

## **AM Antenna Connections**

A molded plastic loop antenna is supplied with your T/DQ-1600. To install the antenna, snap it into its receptacle clip on the rear panel and connect the two wires to the posts labeled AM and GND. You can swivel the antenna away from the rear panel for better AM reception. **Note:** Never try to lift your T/DQ-1600 by this AM antenna; it will not support its weight and the antenna or its bracket may break.

## **External Remote Control Connection**

Your T/DQ-1600 accepts the input of any popular infrared repeater system to facilitate remote control operation from another room or when your tuner is installed within a closed cabinet. This connector is a popular 1/8" (3.5 mm) mini jack and its center conductor is +, the outer is -. For further details contact your Parasound dealer or custom installer.

## **AC Line Cord**

The high-quality IEC standard AC cord supplied with your T/DQ-1600 should be connected directly to an AC wall outlet or an unswitched outlet on your preamplifier or receiver that is always "live." This will insure that your preset stations will remain programmed even when your system is turned off.

## **Operating your T/DQ-1600**

Before turning the unit on, recheck all your connections and turn down the volume control on your preamplifier to avoid any unpleasant "blasts" that could damage your speakers.

### **On-Off Switch**

Push once to turn on. Push again to turn off. The fluorescent display will light up within about 2 seconds.

### **Preset Buttons 1-8**

Press these buttons to recall a preset station. You can use the front panel preset buttons in conjunction with the +10 shift button on the front panel for a total of 16 of the 20 available preset FM or AM stations.

### **+10 Shift Button**

Press and hold this button to shift to the upper level of preset stations. For example to select preset 16, press the +10 button then press preset 6; to select preset 11, press the +10 button then press preset 1.

### **Memory Button**

Press this button to program the preset stations into memory. To preset a station first press memory, then press the preset number. You have 5 seconds after you press memory to store a preset. The memory button can also be used in conjunction with the +10 button.

### **AM/FM Button**

Press this button to toggle between the FM and AM frequency bands. This switch automatically operates according to how you have programmed your presets.

### **Mono/Mute Off Button**

Your T/DQ-1600 has a circuit that will automatically mute weak or distant stations with excessive interchannel noise. Press the MONO button prior to tuning in weaker stations. This button will defeat the muting circuit and receive the station in mono to significantly reduce the level of noise.

## Auto and Tuning Buttons

This button controls the operation of the up and down tuning buttons. When the AUTO is button engaged, the tuning buttons will advance to the nearest station with enough strength for the tuning circuitry to lock onto. With the AUTO button disengaged, the tuning buttons advance in increments of 100 kHz for FM and 10 kHz for AM (50 kHz for FM and 9 kHz for AM in Europe) whether or not there is a station available at the selected frequency.

## Front Panel Display

The front panel display of your T/DQ-1600 will indicate the following functions:

- The selected broadcast frequency
- The selected frequency bandwidth (AM or FM)
- The selected frequency range (MHz for FM or kHz for AM)
- A tuned signal presence indicator showing that adequate strength signal is available
- The selected station preset between 1 and 20. If the frequency selected is not a preset station, this indicator will not light.

## Remote Control

The remote control included with your T/DQ-1600 is the same remote used to control the Parasound P/LD-1100 and P/LD-2000. When using the T/DQ-1600 with either of these preamplifiers, you only have to use one of the provided remote handsets to control all of the functions of both units.

The remote control duplicates every function on the front panel of your T/DQ-1600 with the following exceptions:

- The remote control has the capability of an additional two station presets on the remote control with the buttons labeled P9 and P10 for a total of 20 presets.
- The handset Polarity button has corresponding circuitry only in the Parasound P/LD-2000 preamplifier, and it has no function on your T/DQ-1600.

The remote control transmitter has a range of approximately 20 feet. Use only AA alkaline batteries in the handset and observe the correct polarity which is marked in the case.

## Maintaining your T/DQ-1600

Your T/DQ-1600 requires no periodic maintenance and has no user serviceable parts inside. Do not remove the top cover to avoid risk of electric shock. To keep it clean use only a soft cloth and never use any solvents or abrasives. Fingerprints may be removed with a soft cloth moistened only with a few drops of clear water.

Your T/DQ-1600 has corrosion-free gold RCA jacks, but each year it is a good idea to twist the input plugs to preserve perfect signal transfer by removing corrosion which might have accumulated on the connecting plugs themselves. *Make sure the unit is turned off while you do this.*

The remote control handset batteries should be removed whenever it will be unused for an extended period. Remove the battery cover annually to inspect and remove leaking batteries.

## Power Fuse

If this fuse blows, it is an indication of internal parts failure. Do not replace it with any larger value to avoid damage to internal parts. *Substitution of a larger fuse will void your warranty.*

## In Case of Trouble

If you are experiencing problems with your T/DQ-1600, please refer to the troubleshooting chart below.

<b>Problem</b>	<b>Possible Remedy</b>
One channel out	Bad connection at preamplifier or power amplifier. <i>Check all audio and speaker connections.</i>
Noisy reception	Bad connection at antenna. <i>Check antenna connections.</i>  Poorly located antenna. <i>Try repositioning antenna or installing an outdoor antenna.</i>  Interference from CD player or LD player. <i>Turn off power switch of CD or LD player.</i>  Weak station. <i>Engage mono button or reposition antenna</i>
Loses preset memory	Power loss to the tuner. <i>Make sure it is plugged into an unswitched power outlet. Do not switch off AC to T/DQ-1600.</i>
Remote does not operate unit	Low batteries. <i>Check batteries in remote.</i>  IR Interference. <i>Check to insure that the front panel IR receiver is not exposed to sunlight, etc.</i>

If you are still having problems, contact your authorized Parasound dealer or call Parasound Technical Services. We can suggest other diagnostic tests you can easily perform and which will save you a lot of trouble.

If we determine that your T/DQ-1600 should be returned to Parasound for inspection and possible servicing, you must first obtain a Return Authorization number from Parasound. You will be asked to repack the unit in its original carton and cardboard packing *plus* an additional outer box over its own box for proper protection in transit. You must include your power cord and remote control handset. The Return Authorization number must be clearly marked on the outer carton only. You should ship the unit by UPS with adequate insurance specified. You must include a copy of your purchase receipt to validate your ownership.

Units that arrive without your specific Return Authorization number, without a suitable shipping carton or evidence of improper internal packing or collect will be refused. We do not accept collect shipments. After repair under warranty, the unit will be returned to you via prepaid UPS. If we found no problem with the unit, we will ship the unit by UPS collect for return shipping charges. In the case of an out of warranty repair, we will advise you repair charges before you ship the unit. The same packing requirements and RA requirement apply.

## T/DQ-1600 Specifications

### **Tuning Range**

**FM:** 87.5 MHz to 108 MHz

**AM:** 520 kHz to 1610 kHz

### **FM Sensitivity**

**Mono** IHF 10.8 dBf

**Stereo** IHF 37.2 for 50 dB of quieting

### **AM Sensitivity**

IHF 175 uV/m

### **FM Stereo Separation**

50 dB @ 1 kHz

40 dB @ 10 kHz

### **FM Selectivity**

80 dB

### **AM Selectivity**

50 dB

### **FM Frequency Response**

20 Hz to 15 kHz +/- 1 dB

### **AM Frequency Response**

20 Hz to 4.5 kHz +/- 2 dB

### **Total Harmonic Distortion**

**FM Mono**  $\leq 0.07\%$

**FM Stereo**  $\leq 0.1\%$

### **Total Harmonic Distortion**

**AM**  $\leq 0.5\%$

### **Capture Ratio**

1 dB

### **AM Suppression**

60 dB

### **Dimensions**

19" wide x 3 1/2" high x 12 3/8" deep 4 1/8" high with feet

### **Power Requirements**

110 V - 120 V AC, 8 W; may be rewired for 220 V - 240 V, 50 Hz

**Weight** 12 lb.

## Special Features

- Ultra Wideband IF Section
- CMOS Solid State Switching
- Regulated Power Supply
- Audiophile-grade Components
- Twenty Station Presets
- Fully Remote Controlled
- Auto Scan Circuitry
- Silver-plated internal wiring
- 19" Rack Mount Front Panel
- Unified Remote Handset
- Rear Panel IR Connection
- Heavy-duty chassis

Feature and specifications subject to change or improvement without notice.

## Rewiring for 220 V - 240 V 50 Hz Operation

Your T/DQ-1600 may be rewired for operation abroad. This involves changing power transformer wiring. Please refer this conversion to a skilled electronics technician to avoid personal injury or possible harm to the unit. There are high voltages present inside the chassis even after the power is turned off and the AC plug has been disconnected.

For 110 V - 120 V operation, connect the red and violet transformer primary wires together, then connect the white and gray primary wires together. Next, connect the white/gray wires to one leg of the 110 V-120 V source and the red/violet wires to the other leg of the 110 V-120 V source.

To convert to 220 V - 240 V operation, first disconnect the white wire from the gray wire and disconnect the violet primary wire from the red primary wire. Next, connect the white and violet wires together. Finally, connect the gray wire to one leg of the 220 V-240 V source, and red wire to the other leg of the 220 V-240 V source.

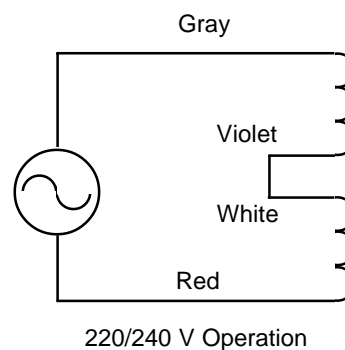
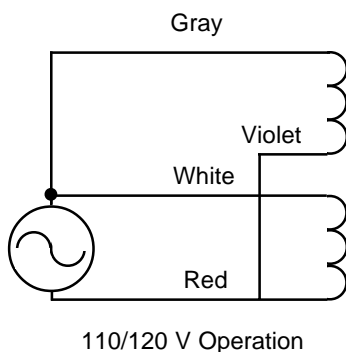

## Parasound Limited Warranty (USA only)

Your Parasound T/DQ-1600 is covered by a limited warranty against defects in materials and workmanship for a period of two years from date of purchase. This warranty is provided by the Parasound dealer where the unit was purchased. Warranty repair will be performed only when your purchase receipt is presented to validate your ownership, date of purchase and authorized status of the selling dealer. Defective parts will be repaired or replaced without charge by your authorized dealer's store or the location designated by your dealer that is authorized to service Parasound equipment. Additional information is available by calling or writing to the Service Manager, Parasound Products, Inc. at the address below. Charges for unauthorized service and transportation costs are not reimbursable under this warranty.

This warranty becomes void if the product has been damaged by alteration, misuse, accident or neglect. Alteration includes any removal, obscuration or defacement of its serial number. This warranty becomes void if unit has been connected or operated contrary to printed instructions. The warrantor assumes no liability for property damage or any other incidental or consequential damage whatsoever which may result from the failure of this product. Any and all warranties of merchantability and fitness implied by law are limited to the duration of this expressed warranty.

Some states do not allow limitations on how long an implied warranty lasts, so the above limitations may not apply to you. Some states do not allow the exclusion or limitation of incidental or consequential damages, so the above limitation or exclusion may not apply to you.

This warranty gives you specific legal rights and you may also have other rights which vary state by state.



PARASOUND

*affordable audio for the critical listener*

*Parasound Products, Inc. 950 Battery Street, San Francisco, CA 94111  
800-822-8802 / 415-397-7100 / FAX 415-397-0144*