

# ONKYO SERVICE MANUAL

## SYNTHESIZED FM STEREO TUNER

### MODEL T-9090

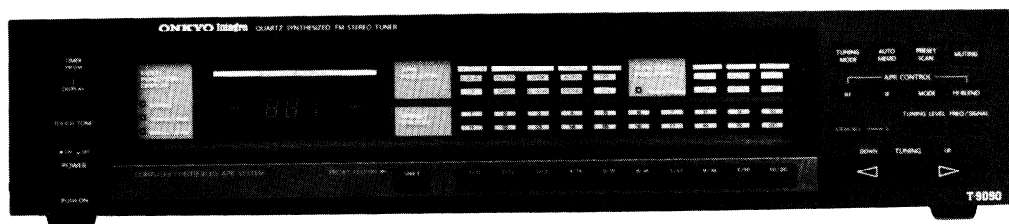

#### SAFETY-RELATED COMPONENT WARNING!!

COMPONENTS IDENTIFIED BY MARK  $\triangle$  ON THE SCHEMATIC DIAGRAM AND IN THE PARTS LIST ARE CRITICAL FOR RISK OF FIRE AND ELECTRIC SHOCK. REPLACE THESE COMPONENTS WITH ONKYO PARTS WHOSE PARTS NUMBERS APPEAR AS SHOWN IN THIS MANUAL.

MAKE LEAKAGE-CURRENT OR RESISTANCE MEASUREMENTS TO DETERMINE THAT EXPOSED PARTS ARE ACCEPTABLY INSULATED FROM THE SUPPLY CIRCUIT BEFORE RETURNING THE APPLIANCE TO THE CUSTOMER.

#### TABLE OF CONTENTS

Specifications . . . . .	2
Service procedures . . . . .	2
Block diagram . . . . .	3
Exploded view . . . . .	4
Parts list . . . . .	5
Block diagram of IC . . . . .	6
Adjustment procedures . . . . .	12
Schematic diagram . . . . .	17
Printed circuit board parts list . . . . .	19
Packing view . . . . .	23

**ONKYO**  
**AUDIO COMPONENTS**

# SPECIFICATIONS

## (120V model)

Tuning Range:	87.9 – 107.9 MHz (200kHz steps)
Usable Sensitivity:	Mono: 12.8dBf, 1.2 $\mu$ V (75 ohms) Stereo: 17.2dBf, 2.0 $\mu$ V
50dB Quieting Sensitivity:	Mono: 15.8dBf, 1.7 $\mu$ V Stereo: 37.2dBf, 20 $\mu$ V
Capture Ratio:	1.0dB
Intermodulation:	110dB
Image Rejection Ratio:	100dB
IF Rejection Ratio:	100dB
Signal-to-Noise Ratio:	Mono: 95dB (IHF) Stereo: 85dB (IHF)
Alternate Channel Att:	80dB IHF ( $\pm$ 400kHz, IF: super narrow)
AM Suppression Ratio:	60dB
Total Harmonic Distortion:	Mono: 0.009% (IF : wide) Stereo: 0.02% (IF : wide)
Frequency Response:	30 – 15,000Hz+0.5dB, -1.0dB
Stereo Separation:	55dB at 1kHz (IF : wide) 33dB at 70 – 10,000Hz (IF : wide)
Output Voltage:	0 – 1.5V
<b>General</b>	
Power Supply:	AC120V, 60Hz
Antennas:	75 ohms unbalanced
Semiconductors:	FETs: 18 Transistors: 38 ICs: 22 Diodes: 86 LEDs: 41
Dimensions (W x H x D):	450 x 99 x 388mm (17 3/4" x 4" x 15 3/8")
Weight:	6.6 kg., 14.5 lbs.

- Specifications and features are subject to change without notice.

# SERVICE PROCEDURES

## 1. Replacing the lamp

This unit uses the lamp listed below.

Circuit no.	Parts no.	Description
PL921	210064A	PL 6.3V, 250mA, Dial plate illumination

## 2. Safety-check out (D model)

After correcting the original service problem, perform the following safety check before releasing the set to the customer:

Connect the insulating-resistance tester between the plug of power supply cable and nickel screw on the back panel.

Specification: 3.3M $\Omega$   $\pm$ 10% at 500V

## 3. Change of De-emphasis

W models are equipped with a 50 $\mu$ sec-75 $\mu$ sec selector switch. This switch is located on the back panel. This switch is set to 50 $\mu$ sec at the factory, but may have to be reset to 75 $\mu$ sec depending on the area where the unit is used.

Europe: 50 $\mu$ sec

U.S.A.: 75 $\mu$ sec

## (other models)

Tuning Range:	87.5 – 108.0 MHz (50kHz steps)
Usable Sensitivity:	Mono: 0.8 $\mu$ V (S/N 26dB, 40kHz Dev.) DIN Stereo: 20.0 $\mu$ V (S/N 46dB, 40kHz Dev.) DIN
50dB Quieting Sensitivity:	Mono: 15.8dBf, 1.7 $\mu$ V Stereo: 37.2dBf, 20 $\mu$ V
Capture Ratio:	1.0dB
Intermodulation:	110dB
Image Rejection Ratio:	100dB
IF Rejection Ratio:	100dB
Signal-to-Noise Ratio:	Mono: 95dB (IHF) Stereo: 85dB (IHF)
Selectivity:	80dB ( $\pm$ 300kHz, IF : super narrow)
AM Suppression Ratio:	60dB
Total Harmonic Distortion:	Mono: 0.009% (IF : wide) Stereo: 0.02% (IF : wide)
Frequency Response:	30 – 15,000Hz+0.5dB, -1.0dB
Stereo Separation:	55dB at 1kHz (IF : wide) 33dB at 70 – 10,000Hz (IF : wide)
Output Voltage:	0–1.5V
<b>General</b>	
Power Supply:	AC220V, 50Hz AC120/220V, 50/60Hz
Antennas:	75 ohms unbalanced (DIN socket)
Semiconductors:	FETs: 18 Transistors: 38 ICs: 22 Diodes: 86 LEDs: 41
Dimensions (W x H x D):	450 x 99 x 388mm (17 3/4" x 4" x 15 3/8")
Weight:	6.6 kg., 14.5 lbs.

## 4. Change of voltage

W models are equipped with a voltage selector to conform with local power supplies. This switch is located on the back panel. Be sure to set this switch to match the voltage of the power supply in your area before turning the power switch on.

This switch is set to 220V at the factory. Voltage is changed by sliding the groove in the switch with the screwdriver to the right or left. Confirm that the switch has been moved all the way to the right or left before turning the power switch on.

## 5. Memory Preservation

This unit does not require memory preservation batteries. A built-in memory power back-up system preserves contents of the memory during power failures and even when the unit is unplugged. The unit must be plugged in and the power switch turned on and off once in order to charge the back-up system. Note that since this is not a permanent memory, the power switch must be turned on and off a few times each month to keep the back-up system operable. The period of time during which memory contents are preserved after power has last been turned off varies depending on climate and the location and placement of the unit. On the average, memory contents are protected over a period of 3 to 4 weeks (a minimum of 2 weeks) after the last time power has been turned off. This period is shorter when the unit is exposed to very high humidity or used in an area with an extremely humid climate.

# BLOCK DIAGRAM

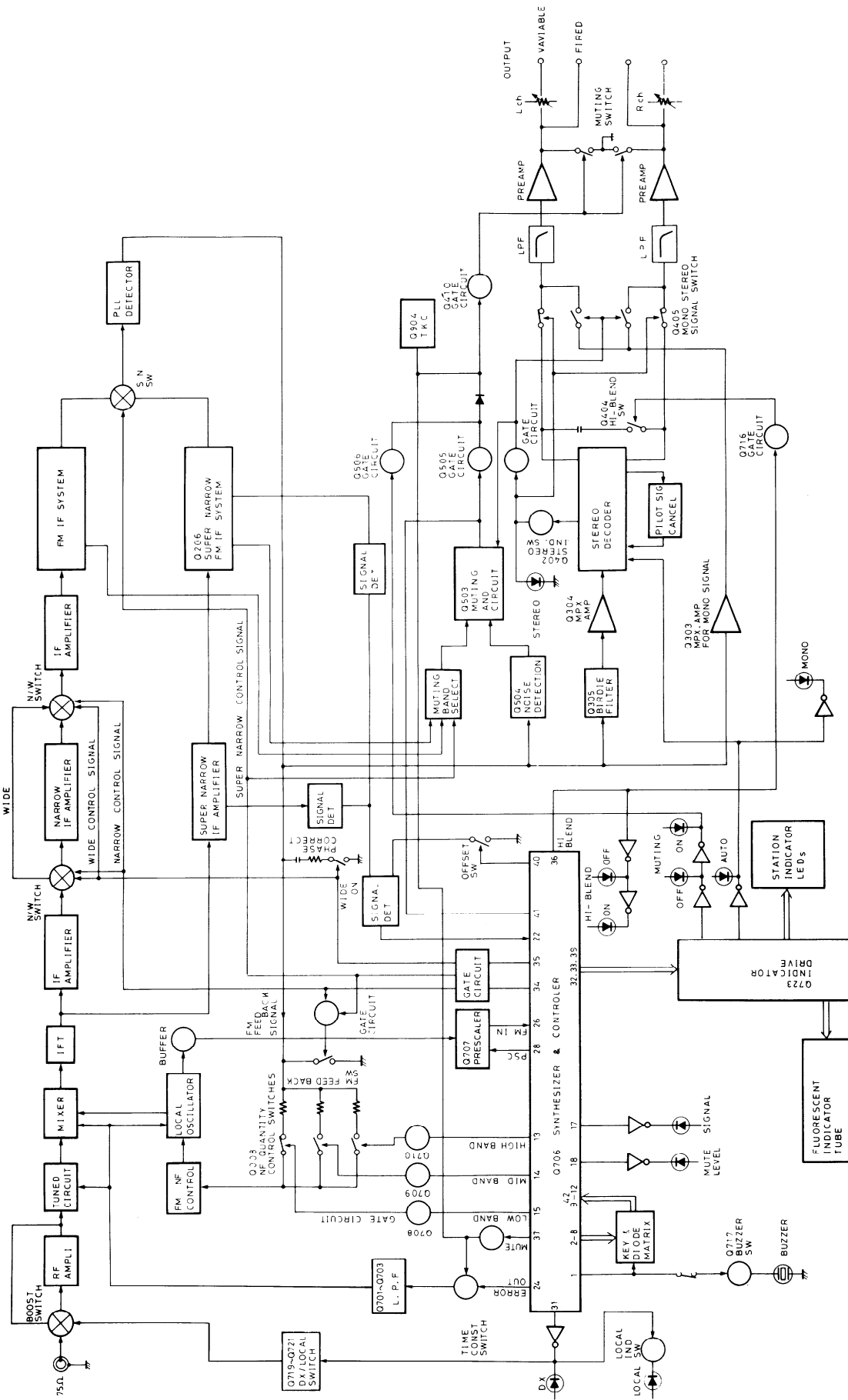

**EXPLODED VIEW**

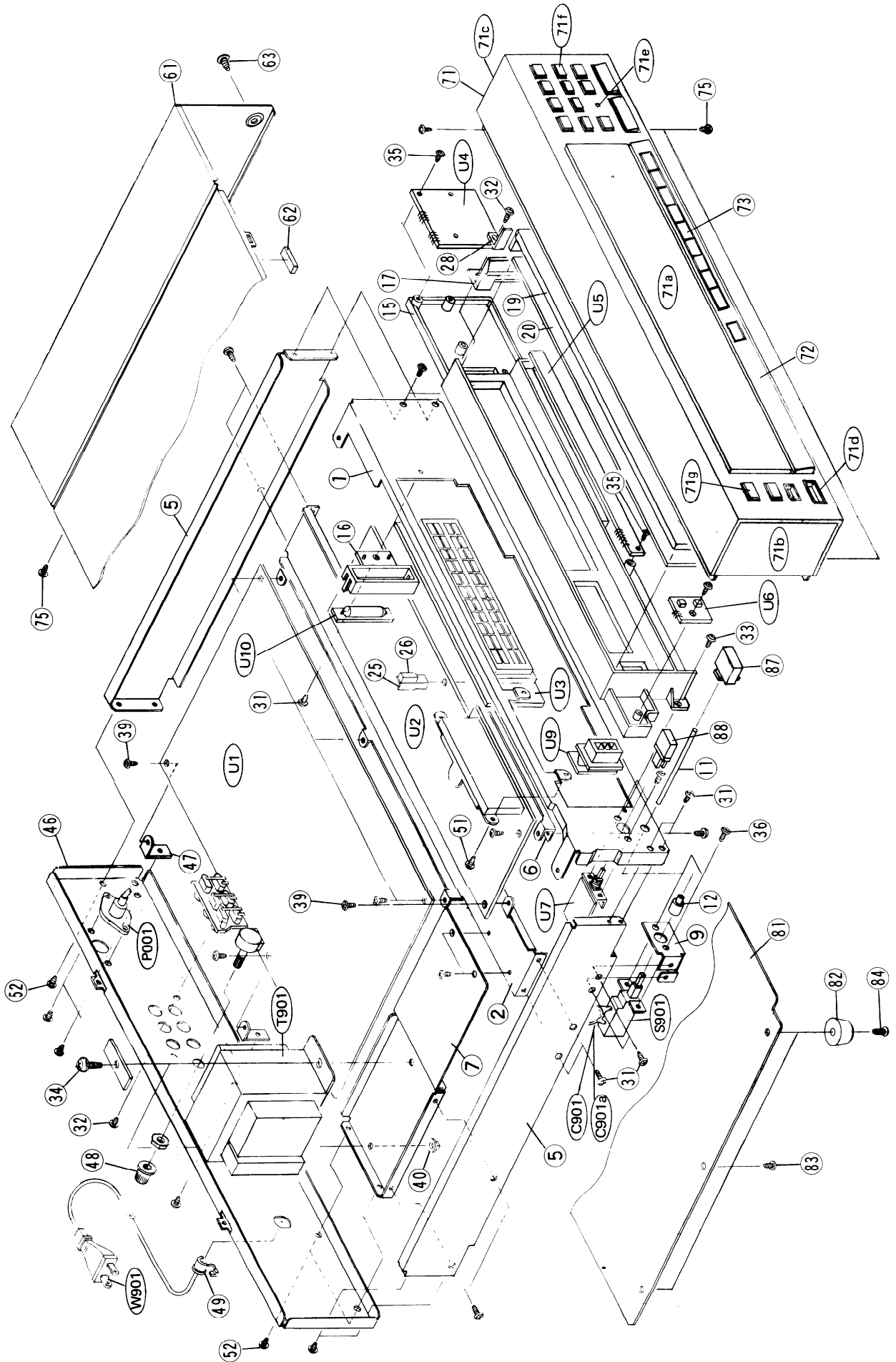

## PARTS LIST

REF. NO.	PART NO.	DESCRIPTION	REF. NO.	PART NO.	DESCRIPTION
1	27110223A	Front bracket	72	27262302A	Plate P
2	27130359B	Bracket F	73	28321642A	Knob, preset
5	27115163	Side bracket	75	834430068	3TTS+6B(BC), Tapping screw
6	27130360	Bracket M	81	27170179	Bottom board
7	27130361A	Bracket, power transformer	82	27175009A	T-C, Leg
9	27140913	Bracket, power switch	83	831430088	3TTW+8B(BC), Tapping screw
11	27160149B	Shaft	84	834430108	3TTS+10B(BC), Tapping screw
12	28320135	Connector	87	28321394	Knob, power
15	27190289A	Holder	88	28321672A	Knob, tone
16	27190290A	Holder, lamp	C901	3500065A	△ 0.01μF, 125V/400V, AC, Capacitor IS
17	27190291	Holder, dial plate			
19	28130218B	Dial plate	C901a	27300601	△ Cover for C901
20	28133105A	Back plate	P1	223004-1	B-5-1, Terminal
25	27140957	Bracket, holder	P001	25045156	Socket, antenna
26	28140563	20×10×6mm, Cushion	R920	431523355	△ 3.3MΩ, 1/2W, Solid resistor [D]
27	28140564	25×5×1.5mm, Cushion	S901	25035295	△ NPS-111-L261P, Power switch
28	27140958	Bracket, pulley	S902	25065123	△ NSS-1258P, Voltage selector switch [W]
31	834430068	3TTS+6B(BC), Tapping screw	T901	230814	△ NPT-843D, Power transformer [D]
32	834430108	3TTS+10B(BC), Tapping screw		230816	△ NPT-843G, Power transformer [G]
33	831430088	3TTW+8B(BC), Tapping screw		230815	△ NPT-843DG, Power transformer [W]
34	830440109	4TTC+10C(BC), Tapping screw	U1	18308588	NARF-2088, FM RF/IF/MPX and power supply circuit pc board ass'y [D]
35	834430080	3TTP+8P(BC), Tapping screw		18314588B	NARF-2088b, FM RF/IF/MPX and power supply circuit pc board ass'y [G]
36	82143006	3P+6FN(BC), Pan head screw		18310588A	NARF-2088a, FM RF/IF/MPX and power supply circuit pc board ass'y [W]
38	870065	Special washer	U2	18308589	NADG-2089, Digital circuit pc board ass'y [D]
39	831130088	3TTW+8B, Tapping screw		18314589B	NADG-2089b, Digital circuit pc board ass'y [G]
40	86414010	FWN4×10FN, Flange nut		18310589A	NADG-2089a, Digital circuit pc board ass'y [W]
46	27120620A	Back panel [D]	U3	18308590	NALED-2090, Indicator pc board ass'y
	27120621A	Back panel [G]	U4	18308591	NASW-2091, Operation switch pc board ass'y
	27120622A	Back panel [W]	U5	18308592	NASW-2092, Station switch pc board ass'y
47	27140914	Bracket, back	U6	18308593	NASW-2093, Program/Display switch pc board ass'y
48	28320540	Knob L	U7	18308594	NASW-2094, Touch tone switch pc board ass'y
49	270280	△ SR-4K-4, Strainrelief	U8	18310595	NASW-2095, De-emphasis switch pc board ass'y [W]
51	834430068	3TTS+6B(BC), Tapping screw	U9	18308596	NALED-2096, Indicator pc board ass'y
52	801230	3TTS+8BQ(BC), Tapping screw	U10	18308597	NAPL-2097, Dial illumination lamp pc board ass'y
53	834230108	3TTS+10B(Ni), Nickel screw	W901	253112	△ AS-UC-4#18, Power supply cord [D]
54	82143006	3P+6FN(BC), Pan head screw		253083-1	△ AS-CEE, Power supply cord [G/W]
61	28184124-1A	Top cover			
62	28140020	10×40×4, Cushion			
63	838440089	4TTB+8C(BC), Tapping screw			
71	18308121	Front panel ass'y			
71a	28191262	Clear plate			
71b	28125103	End cap L			
71c	28125104	End cap R			
71d	27267279	Guide, power			
71e	28198592	Facet			
71f	28321655B	Knob, tuning			
71g	28321669A	Knob, timer			

NOTE: THE COMPONENTS IDENTIFIED BY MARK △ ARE CRITICAL FOR RISK OF FIRE AND ELECTRIC SHOCK. REPLACE ONLY WITH PARTS NUMBER SPECIFIED.

[D] : Only 120V model  
[G] : Only 220V model  
[W] : Only Universal model

# BLOCK DIAGRAM OF IC

μPD1712CU-712-513 (Synthesizer and controller)

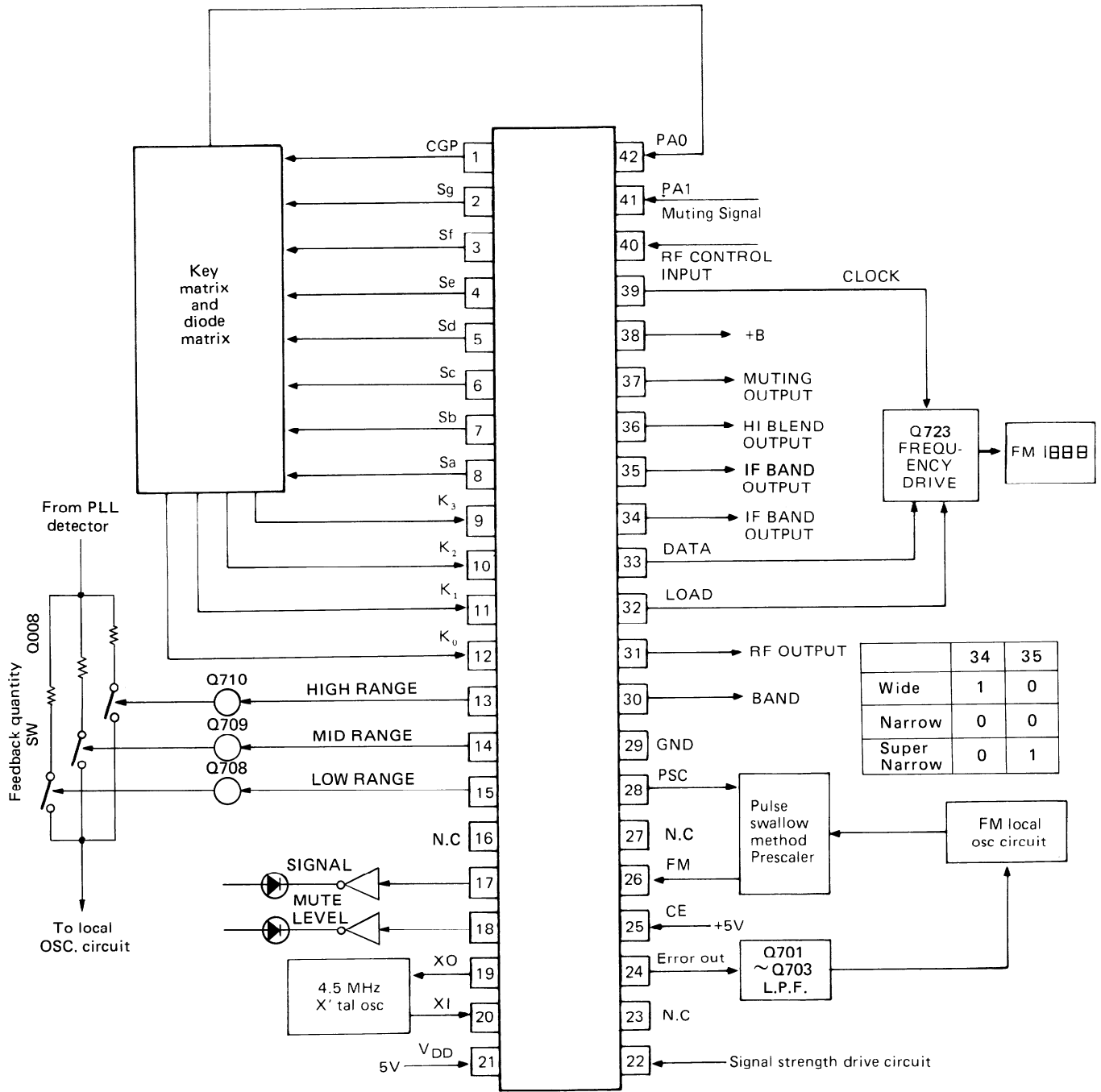

## Matrix circuit

	PAD (42)	K3 (9)	K2 (10)	K1 (11)	K0 (12)
Sg (2)	MEMORY	UP	DOWN	AUTO/MANUAL	
Sf (3)	DISPLAY	PROGRAM	AUTO MEMORY	PRESET SCAN	PRESET REVERSE
Se (4)	M5/M15	M4/M14	M3/M13	M2/M12	M1/M11
Sd (5)	M10/M20	M9/M19	M8/M18	M7/M17	M6/M16
Sc (6)		HI-BLEND	IF	RF	MUTE LEVEL
Sb (7)			SIGNAL/FREQ	MUTING	MONO/STEREO
Sa (8)	TEST		APR DEFEAT		
CGP (1)	BAND 2	BAND 1	BAND 0	PRESET	APR

1	CGP	Buzzer drive output and Key return signal source of diode matrix . Active high.
2	Sg	Key return signal source output terminals. Active high.
3	Sf	
4	Se	
5	Sd	
6	Sc	
7	Sb	
8	Sa	
9	K3	Terminals for input of the key return matrix and diode matrix.
10	K2	
11	K1	
12	K0	
13	D6	These terminals output signal that switches the frequency range of FM to 3 divided. Active high.
14	D5	
15	D4	
16	D3	N.C
17	D2	Signal indicator output. Active high.
18	D1	Muting level indicator output. Active high.
19	X0	Connect to the 4.5MHz crystal oscillator.
20	X1	
21	V <sub>DD</sub>	Device power terminal; supplies 5V during normal operation and 3V from the super capacitor C804 for memory preservation.
22	AD	A/D converter input terminal.
23	E02	Charge pump output of the phase detector which constitutes the PLL. High level is output when the divided oscillation frequency is higher than the reference frequency. In the opposite case, Low level is output. Floating occurs when the frequencies match. The output is applied to the variable capacitor diode in the local oscillation circuit of FM through low pass filter Q701, Q702 and Q703. The output from both terminals is the same, but only E01 is used.
24	E01	
25	CE	Chip enable input. Device selection signal terminal. High level . . . Normal operation Low level . . . Memory preservation.
26	FM	FM local oscillator input.
27	AM	AM local oscillator input. Not used.
28	PSC	Output to control the division ratio of the prescaler.
29	GND	Ground terminal
30	PB3	FM/AM band selector output. FM at the high level.
31	PB2	DX/LOCAL selector output. DX at the high level.
32	PB1	LOAD output.
33	PB0	DATA output
34	PC3	IF band selector output. Wide position at the high level.
35	PC2	IF band selector output. Super narrow position at the high level.
36	PC1	Output to switch the hi-blend filter. Active low.
37	PC0	Muting output. Active high.
38	INT	Remote control input. Not used.
39	PA3	CLOCK output.
40	PA2	RF control input.
41	PA1	Sensor input.
42	PA0	Key return signal input.

**μPB553AC (Prescaler)**

**Pin Connection**

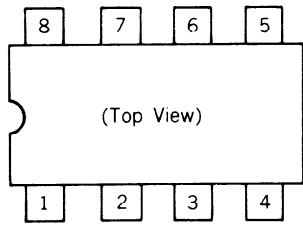

1. Pin 1 (Vcc)..... +5 volts Supply
2. Pin 2 (IN).....FM local oscillator signal input
3. Pin 3 (CHK).....Check terminal
4. Pin 4 (GND).....Ground terminal
5. Pin 5 (OUT).....Prescaler terminal
6. Pin 6 (PSC).....Prescaler control terminal
7. Pin 7,8.....Not connected

**Block Diagram**

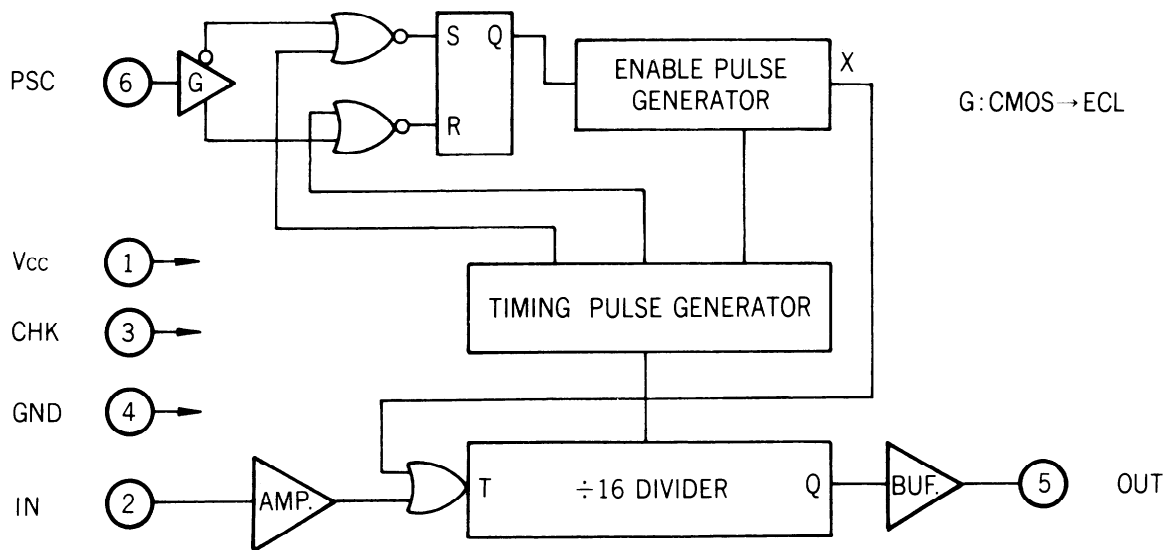

**Timing Chart**

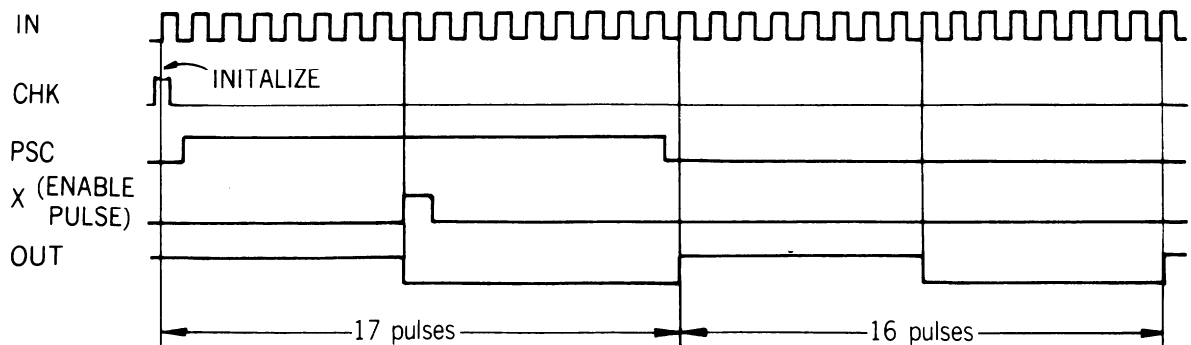



### μPD6320G (Indicator drive)

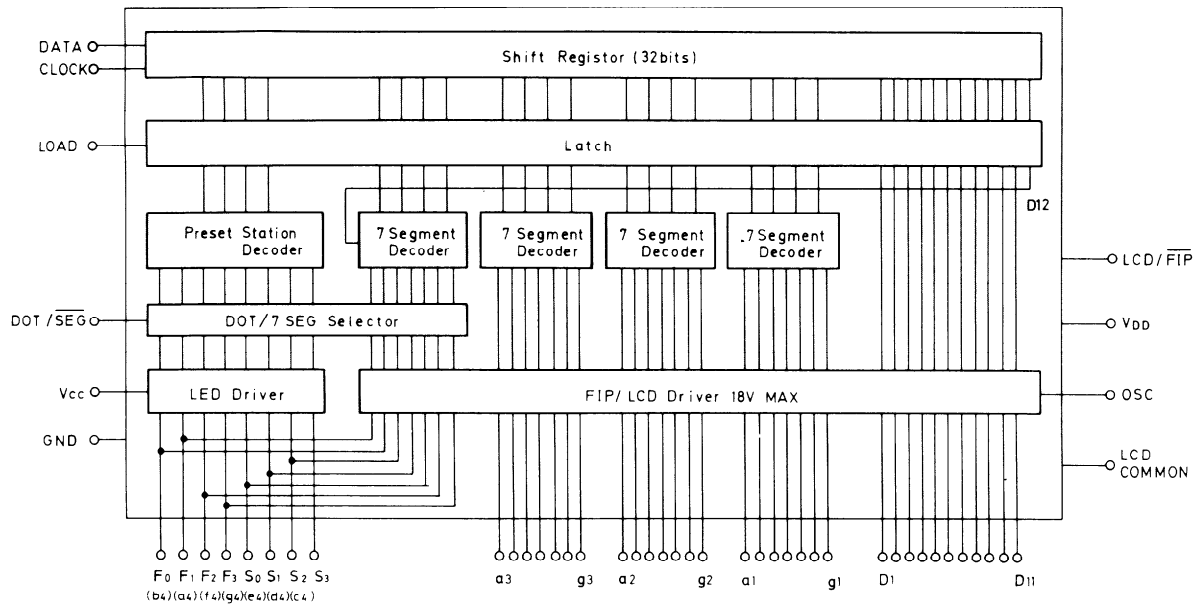

### NJM4560 (Operation amplifier)

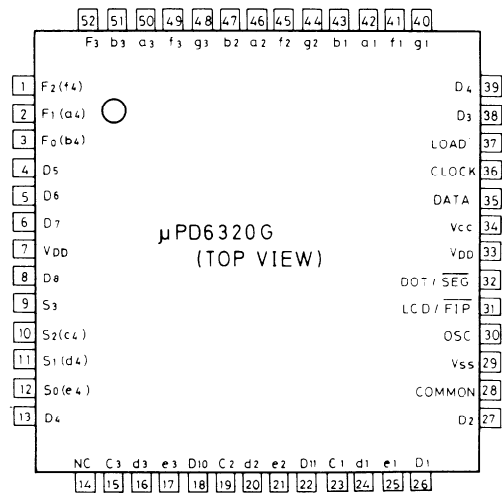
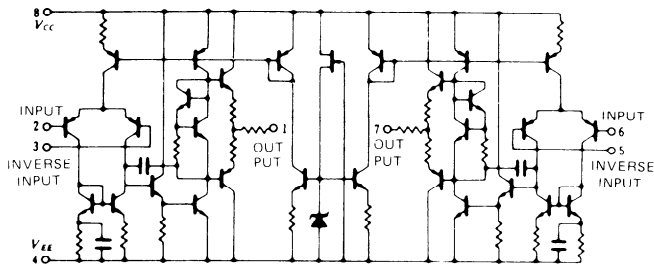

### μPA81C (Indicator drive)

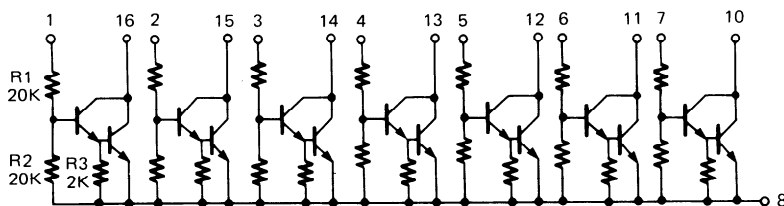

LA1235 (FM IF system)

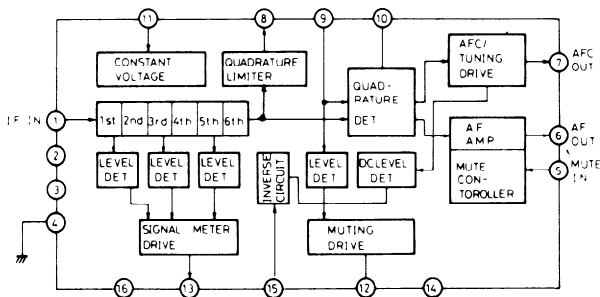

- 1. IF signal input
- 2. IF amplifier switch input  
H level: Off
- 5. Muting switch input
- 6. Composite signal output
- 7. AFC output
- 8. IF amplifier output
- 9. 10.7MHz input
- 10. Reference voltage
- 11. Power supply
- 12. Muting output  
Tuned: L level
- 13. Signal strength output
- 15. Muting level

4066 (Analogue switch)

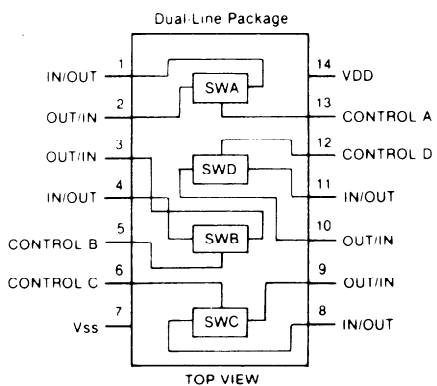

4011B (Naud gate)

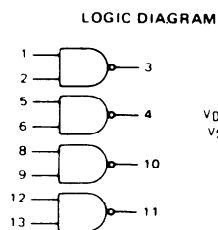

CIRCUIT SCHEMATICS  
(1/4 of Device Shown)

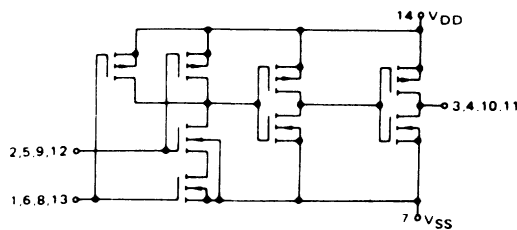

μPC1163H (FM IF amp.)

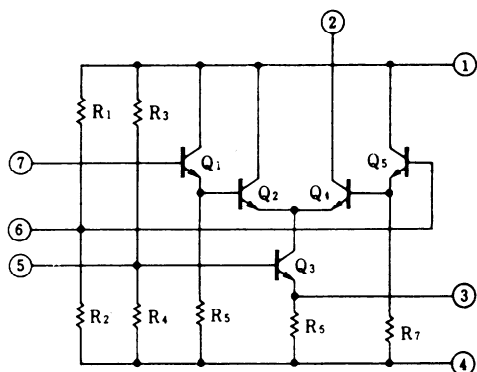

Terminal No.	Operation
1	Vcc
2	OUTPUT
3	BYPASS
4	GND
5	BYPASS
6	INPUT BIAS
7	INPUT

$\mu$  PC1223C (Stereo decoder)

## Block diagram

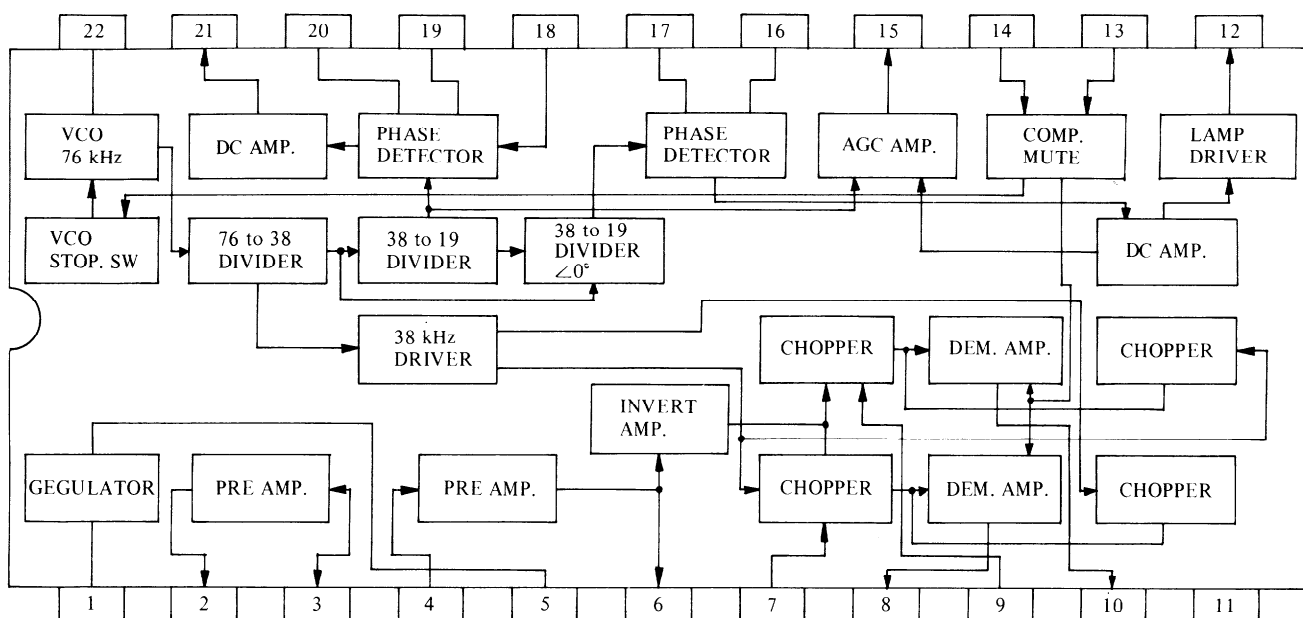

Terminal No.	Connection	Terminal No.	Connection
1	V <sub>cc</sub>	12	ST. LAMP INDICATOR
2	PRE AMP. OUTPUT 1	13	ST-MONO SW & VCO STOP
3	PRE AMP. INPUT 1	14	MUTING SWS
4	PRE AMP. INPUT 2	15	19kHz CANCEL
5	BYPASS	16	LPF
6	PRE AMP. OUTPUT 2	17	LPF
7	POST AMP. INPUT	18	FILTER INPUT
8	L-ch OUTPUT	19	LPF
9	POST AMP. INPUT	20	LPF
10	R-ch OUTPUT	21	LPF
11	GND	22	OSC RC NETWORK

# ADJUSTMENT PROCEDURES

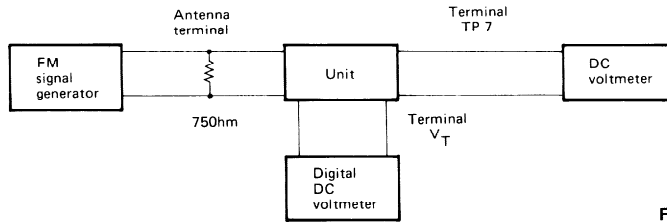

Fig. 1

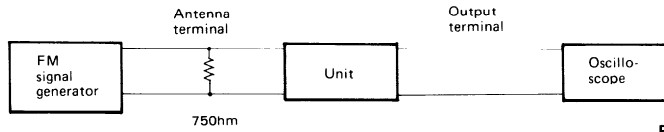

Fig. 2

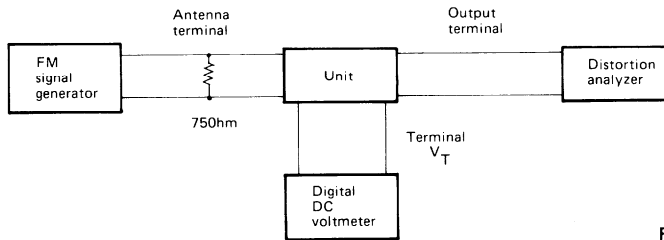

Fig. 3

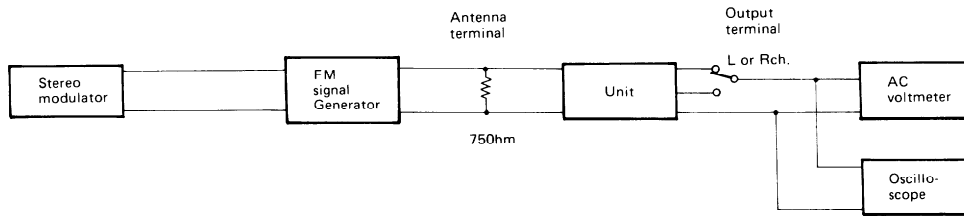
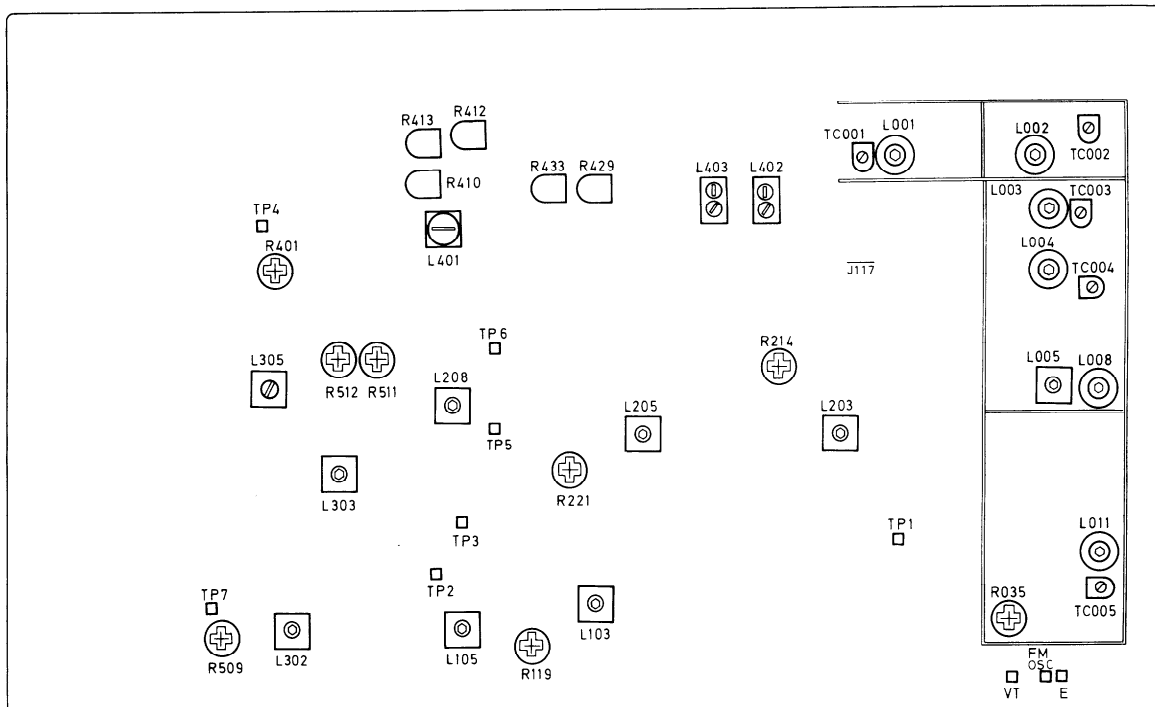

Fig. 4



Item	Step	Connection of instrument	FM SG output	Stereo modulator output	Tuned frequency	Output indicator	Adjustment point	Adjust for	Remarks				
Front End	1	Fig. 1		_____	107.9MHz	Digital DC	TC005	24.0 ± 0.2V	Before adjustment, turn the semi-fixed resistors R509 and R512 fully clockwise. Repeat the steps 1 and 2 until no further adjustment is necessary.				
	2				87.9MHz	voltmeter	L011	4.0 ± 0.1V					
	3				107.9MHz 1kHz, 75kHz dev. 10dB/ $\mu$ V (15.2dB $\Omega$ )	DC	TC001, TC002, TC003, TC004, L008	Maximum		Repeat the steps 3 and 4 until no further adjustment is necessary.			
	4				87.9MHz 1kHz, 75kHz dev. 10dB/ $\mu$ V (15.2dB $\Omega$ )	voltmeter	L001, L002, L003, L004, L203, L205	Maximum					
	5							Maximum					
IF level of wide & narrow		Connect the DC voltmeter to pin 13 of Q106	99.1MHz 1kHz, 75kHz dev. 10dB/ $\mu$ V (15.2dB $\Omega$ )	_____	99.1MHz	DC voltmeter	L005, L103	Maximum					
IF level of super narrow		Fig.1	99.1MHz 1kHz, 75kHz dev. 10dB/ $\mu$ V (15.2dB $\Omega$ )	_____	99.1MHz	DC voltmeter	L203, L205	Maximum					
Muting level of wide and narrow	1	Fig.2 Connect the DC voltmeter to terminals TP-2 and TP-5	99.1MHz 1kHz, 75kHz dev. 60dB/ $\mu$ V (6.5dB $\Omega$ )	_____	99.1MHz	DC voltmeter	L105	0V					
	2									99.1MHz 12dB/ $\mu$ V (1.7.5dB $\Omega$ )	Oscilloscope	R119	Muting circuit opens.
Muting level of super narrow	1	Fig. 2 Connect the DC voltmeter to terminals TP-4 and TP-5	99.1MHz 1kHz, 75kHz dev. 60dB/ $\mu$ V (6.5dB $\Omega$ )	_____	99.1MHz	DC voltmeter	L208	0V					
	2									99.1MHz 12dB/ $\mu$ V (1.7.5dB $\Omega$ )	Oscilloscope	R221	Muting circuit opens.
P.L. detector		Connect the DC voltmeter to Jumper lead J117	99.1MHz 1kHz, 75kHz dev. 80dB/ $\mu$ V (8.5dB $\Omega$ )	_____	99.1MHz	DC voltmeter	L303	0V	IF band: Wide RF: DX				
FM feedback		Fig. 3	99.1MHz 400Hz, 75kHz dev. 80dB/ $\mu$ V (8.5dB $\Omega$ )	_____	99.1MHz	Distortion analyzer	R035	Minimum	Before adjustment, set the semi-fixed resistor R035 to the center position.				
										Digital DC voltmeter	TC005	Same value before adjustment	
VCO		Connect the frequency counter to TP4	99.1MHz 1kHz, 75kHz dev. 80dB/ $\mu$ V (8.5dB $\Omega$ )	_____	99.1MHz	Frequency counter	R401	76kHz ± 76Hz					
Carrier leakage		Fig. 4	99.1MHz, 80dB Ext. modulation	Only pilot signal	99.1MHz	AC voltmeter or oscilloscope	L401, R401	Minimum					
	Separation									1	99.1MHz Ext. modulation 80dB/ $\mu$ V (8.5dB $\Omega$ )	Oscilloscope	R413
Signal meter	1		99.1MHz, 5dB/ $\mu$ V	L channel	99.1MHz	AC voltmeter or oscilloscope	R429	Separation of L and R are same and maximum.	IF band: Super narrow				
	2									60dB/ $\mu$ V	R channel	R433	Separation of L and R are same and maximum.
	3									90dB/ $\mu$ V	R channel	R214	95dB

# SCHEMATIC DIAGRAM

A B C D

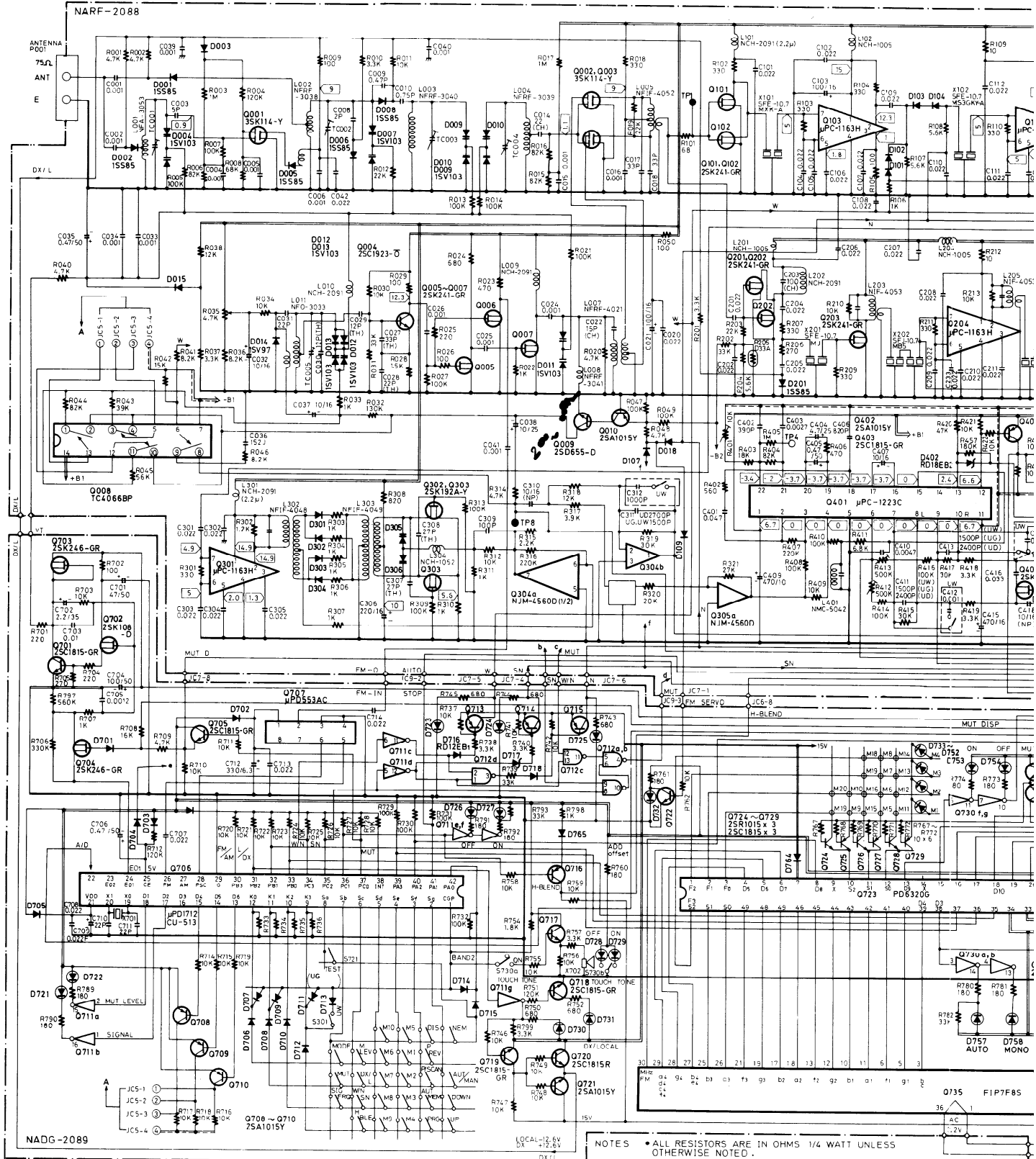

- NOTES
- ALL RESISTORS ARE IN OHMS 1/4 WATT UNLESS OTHERWISE NOTED.
  - ALL CAPACITORS ARE IN μF 50VW UNLESS OTHERWISE NOTED.
  - ELECTROLYTIC CAPACITORS ARE IN μF/VV.
  - CIRCUIT IS SUBJECT TO CHANGE FOR IMPROVEMENT.
  - THE COMPONENTS IDENTIFIED BY MARK ARE CRITICAL FOR SAFETY.
  - VOLTAGE (MEASURED WITH V.T.V.M.) IS DC VOLTAGE.
  - ALL DIODES ARE 1S1555 or DS442X or 1S2076 UNLESS OTHERWISE NOTED

1  
2  
3  
4  
5







# PRINTED CIRCUIT BOARD-PARTS LIST

FM RF/IF/MPX and power supply circuit pc board  
(NARF-2088)

CIRCUIT NO.	PART NO.	DESCRIPTION	CIRCUIT NO.	PART NO.	DESCRIPTION
Q008	222575 or 222840661	TC4066BP or 4066	D911, D913 D914 D912	223133 or 223145 2240971 or 2239492	DS442X or 1S2076TD GZA-6. 2X or RD6. 2EB2
Q103, Q104	222474	$\mu$ PC-1163H		Coils	
Q106	222680	LA-1235	L001	233321	NFA-3053
Q204	222474	$\mu$ PC-1163H	L002	233322	NFRF-3038
Q206	222680	LA-1235	L003	233324	NFRF-3040
Q301	222474	$\mu$ PC-1163H	L004	233323	NFRF-3039
Q304, Q305	222579	NJM4560D	L007	233212	NFRF-4021
Q401	222732	$\mu$ PC1223C	L008	233326	NFRF-3041
Q405, Q406	222575 or 222840661	TC4066BP or 4066B	L009, L010	233304	NCH-2091
Q407, Q501	222579	NJM4560D	L011	233325	NF0-3033
Q503	222579	NJM4560D	L012, L101	233304	NCH-2091
Q901	222780151	78M15	L102	233105	NCH-1005
	Transistors		L104	233304	NCH-2091
Q001-Q003	2212514	3SK114(Y)	L201	233105	NCH-1005
Q004	2211723	2SC1923(O)	L202	233304	NCH-2091
Q005-Q007	2212195	2SK241(GR)	L204	233105	NCH-1005
Q009	2211704 or 2211705	2SD655(D) or 2SD655(E)	L206	233304	NCH-2091
Q010	2211454	2SA1015(Y)	L207	233105	NCH-1005
Q101, Q102	2212195	2SK241(GR)	L301	233304	NCH-2091
Q105	2212274	2SK192A(Y)	L304	233241	NCH-1052
Q107	2211723	2SC1923(O)	L305	333319	NMC-6049
Q201-Q203	2212195	2SK241(GR)	L401	233303	NMC-5042
Q205	2211255	2SC1815(GR)	L402, L403	233320	NMC-6050
Q207	2211723	2SC1923(O)	L501	231042 or 233122	NCH-2082 or NCH-3013
Q302, Q303	2212274	2SK192A(Y)	L502	233031	NMC-9-1
Q402	2211454	2SA1015(Y)		Transformers	
Q403	2211255 or 2210746	2SC1815(GR) or 2SC945A(P)	L005	233317	NFIF-4052
Q404	2211945 or 2211944	2SK246(GR) or 2SK246(Y)	L103	233318	NFIF-4053
Q408, Q409	2211704 or 2211705	2SD655(D) or 2SD655(E)	L105, L208	233295	NFIF 4047
Q410, Q906	2211454	2SA1015(Y)	L203, L205	233318	NFIF-4053
Q504-Q506	2211255 or 2210746	2SC1815(GR) or 2SC945A(P)	L302	233296	NFIF-4048
Q903, Q905	2200792 or 2200793	2SB649(B) or 2SB649(C)	L303	233297	NFIF-4049
Q904	2211256	2SC1815(BL)		Ceramic filters	
	Diodes		X101, X104	3010085	SFE10. 7MXK-A
D001, D002	223149	1SS85	X102, X103	3010086	SFE10. 7MS3GKY-A
D103	223133 or 223145	DS442X or 1S2076TD	X201, X203	3010087	SFE10. 7MJ-A
D004, D007	223154	1SV103	X202	3010088	SFJ10. 7MB5-A
D005, D006	223149	1SS85		Capacitors	
D008	223149	1SS85	TC001-TC005	3060017	NTC-10P15, Trimmer
D009-D013	223154	1SV103	C009	3020006	0.47pF $\pm$ 5%, 500V
D014	223148	1SV97	C010	3020007	0.75pF $\pm$ 5%, 500V
D015	223133 or 223145	DS442X or 1S2076TD	C021	352741019	100 $\mu$ F, 16V, Elect.
D017-D019	223145	1S2076TD	C032, C037	352741009	10 $\mu$ F, 16V, Elect.
D101-D110	223133 or 223145	DS442X or 1S2076TD	C035	352784799	0.47 $\mu$ F, 50V, Elect.
D202-D206	223145	1S2076TD	C038	352751009	10 $\mu$ F, 25V, Elect.
D201	223149	1SS85	C103	352741019	100 $\mu$ F, 16V, Elect.
D301-D304	223133 or 223145	DS442X or 1S2076TD	C115	352741009	10 $\mu$ F, 16V, Elect.
D401	223145	1S2076TD	C119	352780109	1 $\mu$ F, 50V, Elect.
D305, D306	223136	KV1226	C128	352780229	2.2 $\mu$ F, 50V, Elect.
D402	2241191 or 2239712	GZA-18X or RD18EB2	C131	352742219	220 $\mu$ F, 16V, Elect.
D502	223132 or 223156	1K60 or 0A99A	C220	352780109	1 $\mu$ F, 50V, Elect.
D503	2240931 or 2239452	GZA5. 1X or RD5. 1EB2	C224	352780229	2.2 $\mu$ F, 50V, Elect.
D505, D506	223133 or 223145	DS442X or 1S2076TD	C230	352741019	100 $\mu$ F, 16V, Elect.
D509-D514	223145	1S2076TD	C306	352742219	220 $\mu$ F, 16V, Elect.
D507	4000068	VD1222	C310	352941006	10 $\mu$ F, 16V, Non-polar elect.
D901	223862	WL-01	C402	370133914	390pF $\pm$ 5%, 100V, APS
D902-D906	223804	SR1K-2	C404	352750479	4.7 $\mu$ F, 25V, Elect.
D907	2241151 or 2239672	GZA15X or RD15FB2	C405	352784799	0.47 $\mu$ F, 50V, Elect.
D908	2239812	RD30EB2	C406	370138214	820pF $\pm$ 5%, 100V, APS
D909, D910	2241011 or 2239532	GZA-7. 5X or RD7. 5EB2	C407, C507	352741009	10 $\mu$ F, 16V, Elect.
			C409, C415	352744719	470 $\mu$ F, 16V, Elect.
			C417-C420	352941006	10 $\mu$ F, 16V, Non-polar elect.
			C504, C505	352784799	0.47 $\mu$ F, 50V, Elect.
			C506	352781099	0.1 $\mu$ F, 50V, Elect.
			C904	384171037	0.01 $\mu$ F, 630V, DT
			C905	352764719	470 $\mu$ F, 35V, Elect.
			C906, C907	352741019	100 $\mu$ F, 16V, Elect.
			C908	352761009	10 $\mu$ F, 35V, Elect.
			C909	352762229	2,200 $\mu$ F, 35V, Elect.
			C910	352753319	330 $\mu$ F, 25V, Elect.
			C911	352742219	220 $\mu$ F, 16V, Elect.

CIRCUIT NO.	PART NO.	DESCRIPTION
C913	352761009	10 $\mu$ F, 35V, Elect.
C914	352761019	100 $\mu$ F, 35V, Elect.
C915	352784719	470 $\mu$ F, 50V, Elect.
C917	352742209	22 $\mu$ F, 16V, Elect.
C918	352744719	470 $\mu$ F, 16V, Elect.
C919, C921	352741019	100 $\mu$ F, 16V, Elect.
	Resistors	
R035	5225019	N10HR4.7KBD, Semi-fixed
R119	5225015	N10HR10KBD, Semi-fixed
R205	4000028	D33A, Thermistor
R214, R221	5225015	N10HR10KBD, Semi-fixed
R401	5225015	N10HR10KBD, Semi-fixed
R410	5215047	N08HR100KBC, Semi-fixed
R412, R413	5215049	N08HR500KBC, Semi-fixed
R429, R433	5215048	N08HR200KBC, Semi-fixed
R452, R453	5146046	N16RGL2KB15, Variable
R509	5225015	N10HR10KBD, Semi-fixed
R511	5225037	N10HR220KBD, Semi-fixed
R512	5225032	N10HR22KBD, Semi-fixed
R903	441626814	680 $\Omega$ , 1W, Metal oxide film
R904	441620274	2.7 $\Omega$ , 1W, Metal oxide film
	Terminal	
	2010102	Antenna cable
	25045137	NPJ-6PDBL52, Output
	Radiator	
	27160146	RAD-52
	Socket	
	25050140	NJPS-3P-S
	Shielded plates	
	27150180	Front end
	27150181	Front end
	27150182	Front end
	27150191	Front end

#### Digital circuit pc board (NADG-2089)

CIRCUIT NO.	PART NO.	DESCRIPTION
	ICs	
Q706	222769	$\mu$ PC1712CU-712-513
Q707	222619	$\mu$ PB553AC
Q711	222807	$\mu$ PA81C
Q712	222513 or 222840111	$\mu$ PD4011B or 4011B
Q723	222770	$\mu$ PD6320G
Q730	222807	$\mu$ PA81C
	Fluorescent indicator tube	
Q735	212023	FIP7F8S
	Transistors	
Q701, Q705	2211255 or	2SC1815(GR) or
Q717, Q718	2210746	2SC945A(P)
Q702	2212294	2SK108(D)
Q703, Q704	2211945	2SK246(GR)
Q708-Q710	2211454	2SA1015(Y)
Q713-Q716	2211454	2SA1015(Y)
Q719, Q721	2211454	2SA1015(Y)
Q720, Q722	2211255 or	2SC1815(GR) or
Q731, Q733	2210746	2SC945A(P)
Q732	2211454	2SA1015(Y)
Q734	2200782	2SD669(B)
	Diodes	
D701, D702	223133 or	DS442X or
D704-D710		
D712	223145	1S2076TD
D714, D715	223133 or	DS442X or
D762-D764	223145	1S2076TD
D703, D765	223133 or 223105	DS442X or 1S1555
D716-D718	2241111 or 2239632	GZA-12X or RD1.2EB1
D719	2241291	RD3.3EB1
D720	2240971 or 2239493	GZA-6.2X or RD6.2EB2
	X'tal	
X701	3010052	XTL-4.5M
	Buzzer	
X702	241048	RKM24-4A0
	Capacitors	
C701	352784709	47 $\mu$ F, 50V, Elect.
C702	395160227	2.2 $\mu$ F, 35V, Tantalum

CIRCUIT NO.	PART NO.	DESCRIPTION
C704	352781019	100 $\mu$ F, 50V, Elect.
C706	352784799	0.47 $\mu$ F, 50V, Elect.
C709	3020017	0.022F, 5V, Super
C712	352723319	330 $\mu$ F, 6.3V, Elect.
C715, C716	352741009	10 $\mu$ F, 16V, Elect.
	Resistors	
R720-R728	49121103509	10k $\Omega$ x9, 1/8W, Network
R729-R732	49121104504	100k $\Omega$ x4, 1/8W, Network
R733-R736	49121104504	100k $\Omega$ x4, 1/8W, Network
R796	441727504	75 $\Omega$ , 2W, Metal oxide film
	Radiator	
	27160145	RAD-51
	Sockets	
	25050141	NJPS-4P-S
	25050145	NJPS-8P-S
	25050147	NJPS-10P-S
	Switch	
S721	25035408	NPS-111-S372
	Bracket	
	27130352	Fluorescent tube

#### Indicator pc board (NALED-2090)

CIRCUIT NO.	PART NO.	DESCRIPTION
	Transistors	
Q724, Q726	2211255 or	2SC1815(GR) or
Q728	2210746	2SC945A(P)
Q725, Q727	2211454	2SA1015(Y)
Q729		
	LEDs	
D723, D726	225137	SEL2413E
D728, D731	225137	SEL2413E
D754, D757	225137	SEL2413E
D760	225137	SEL2413K
D724, D725	225142	SEL2913K
D727, D729	225142	SEL2913K
D730, D756	225142	SEL2913K
D732-D753	225142	SEL2913K
D758, D761	225142	SEL2913K
	Holder	
	27190288A	LED
	Screws	
	833426060	2.6TTP+6P(BC), Tapping

#### Operation switch pc board (NASW-2091)

CIRCUIT NO.	PART NO.	DESCRIPTION
	Switches	
S701-S707	25035389	NPS-111-S353
S720, S721		
S723-S726		
	LED	
	225126	GL3PR1

#### Station switch pc board (NASW-2092)

CIRCUIT NO.	PART NO.	DESCRIPTION
S708-S717	25035408	NPS-111-S372, Push switch
S719		

#### Program/display switch (NASW-2093)

CIRCUIT NO.	PART NO.	DESCRIPTION
S718, S722	25035389	NPS-111-S353, Push switch

#### Touch tone switch pc board (NASW-2094)

CIRCUIT NO.	PART NO.	DESCRIPTION
S730	25035372	NPS-122-L336, Push switch

#### De-emphasis switch pc board (NASW-2095) [Only Universal model]

CIRCUIT NO.	PART NO.	DESCRIPTION
S301	25065240	NSS-42102, Slide switch

# PRINTED CIRCUIT BOARD VIEW FROM BOTTOM SIDE

## DIGITAL CIRCUIT (NADG-2089)

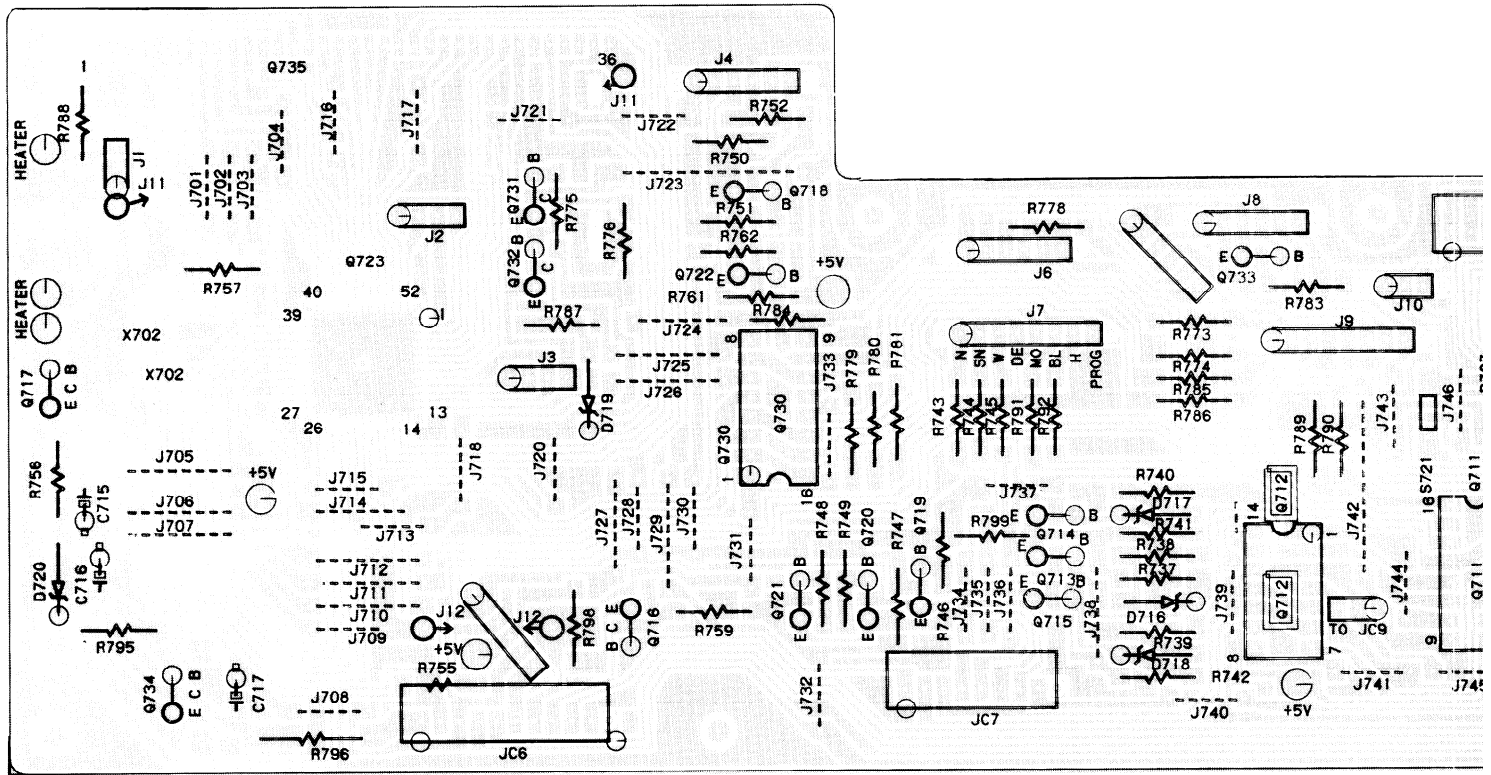

## INDICATOR CIRCUIT (NALED-2090)

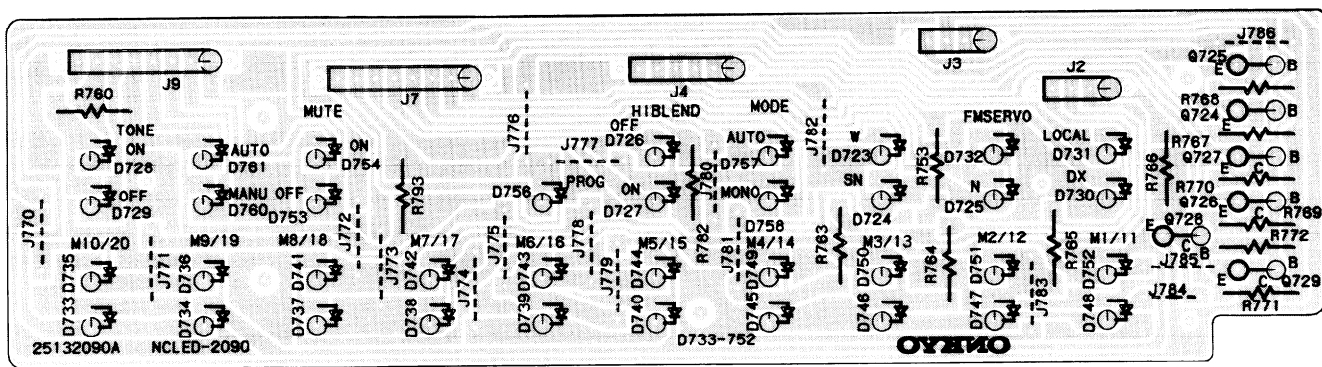

## STATION SWITCH (NASW-2092)

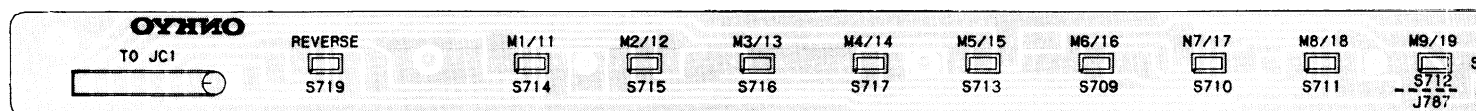

Indicator pc board (NALED-2096)

CIRCUIT NO.	PART NO.	DESCRIPTION
D721, D722	225137	SFL2413F, LED
D755	225142	SEL2913K, LED
	27190292A	Holder, LED
	833426060	2.6TTP+6P(BC), Tapping screw

Dial illumination lamp pc board (NAPL-2097)

CIRCUIT NO.	PART NO.	DESCRIPTION
PL901	210064A	250mA, 6.3V, Lamp

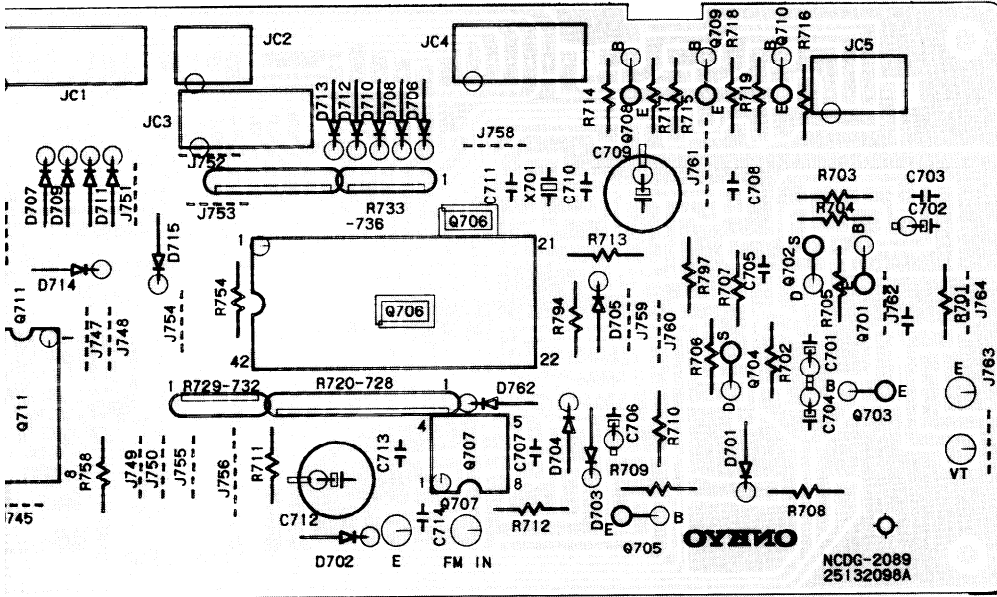

OPERATION SWITCH (NASW-2091)

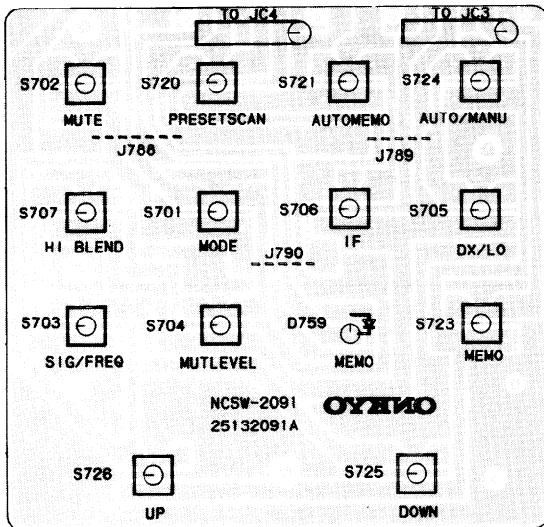

(NASW-2093)

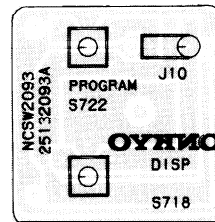

(NASW-2094)

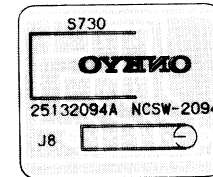

(NALED-2096)

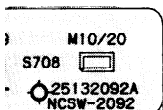
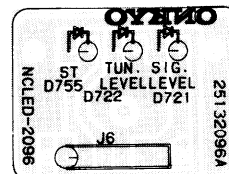

# PACKING VIEW

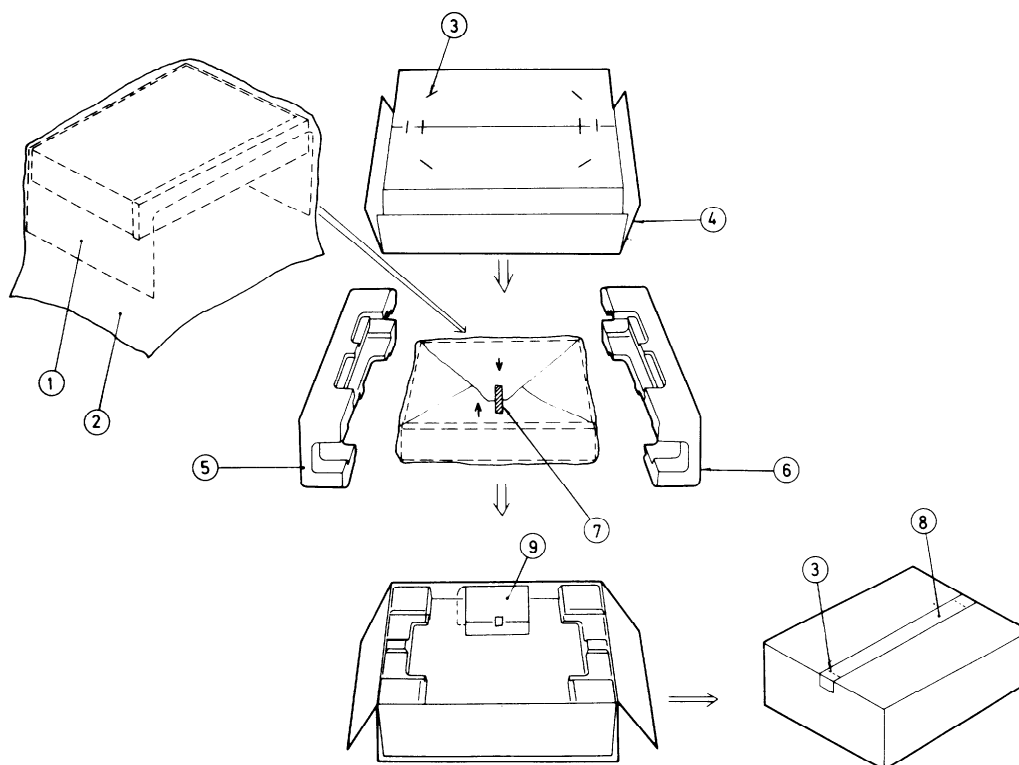

REF. NO.	PARTS NO.	DESCRIPTION
1	29095012-1	500 × 800mm, Protection sheet
2	29100038A	720 × 950mm, Poly=vinyl bag
3	282301	Sealing hook
4	29050981	Master carton box
5	29090921	Pad R
6	29090920	Pad L
7	261504	W=30mm, Adhesive tape
8	260012	50 × 640mm, Damplon tape
9		Accessory bag ass'y
	<b>U.S.A. model</b>	
	29340799	Instruction manual
	2010069	Connection cable
	25060088	FM adaptor
	292064A	FM antenna
	29365006-6	Warranty card
	29358002A	Service station list
	29100006	350 × 250mm, Poly=vinyl bag
	<b>120V model</b>	
	29340799	Instruction manual
	2010069	Connection cable
	25060088	FM adaptor
	292064A	FM antenna
	29100006	350 × 250mm, Poly=vinyl bag
	<b>220V model</b>	
	29340800	Instruction manual
	2010069	Connection cable
	25060088	FM adaptor
	292064A	FM antenna
	29100006	350 × 250mm, Poly=vinyl bag
	<b>Universal model</b>	
	29340800	Instruction manual
	2010069	Connection cable
	25060088	FM adaptor
	292064A	FM antenna
	25055040	CV-K-2, Conversion plug
	29100006	350 × 250mm, Poly=vinyl bag