

- (✓) Squeeze the bare ends of the wires with a pair of pliers until the wires are flattened slightly.
- (✓) Twist lugs 2 and 5 of switch CN 90 degrees as shown.
- () Insert the bare end of one of the large black wires through lug 2 to lug 5 of switch CN. Bend the wire as shown at lug 5. Be sure the insulation of this wire is close to lug 2. Solder lugs 2 and 5.
- (✓) Refer to Part B of Detail 13-5A and insert the bare end of the remaining large black wire through lug 3 to lug 6 of switch CN. Bend the wire as shown at lug 6 to make a mechanically secure connection. Be sure the insulation of this wire is close to lug 3. Solder lugs 3 and 6.
- (✓) Form the large black wires at lugs 2 and 3 of switch CN straight toward the rear of the switch.

- (✓) Refer to Part B of Detail 13-5A and slide the black insulator forward and onto the rear of the switch. Then work the insulator forward, first one side then the other, until the exposed wires and lugs are completely covered and the insulator is over the switch as far as it will go.

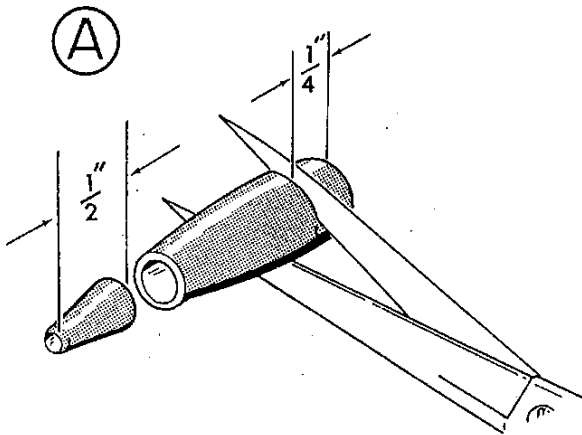

Detail 13-5A

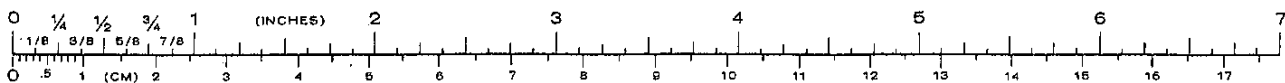
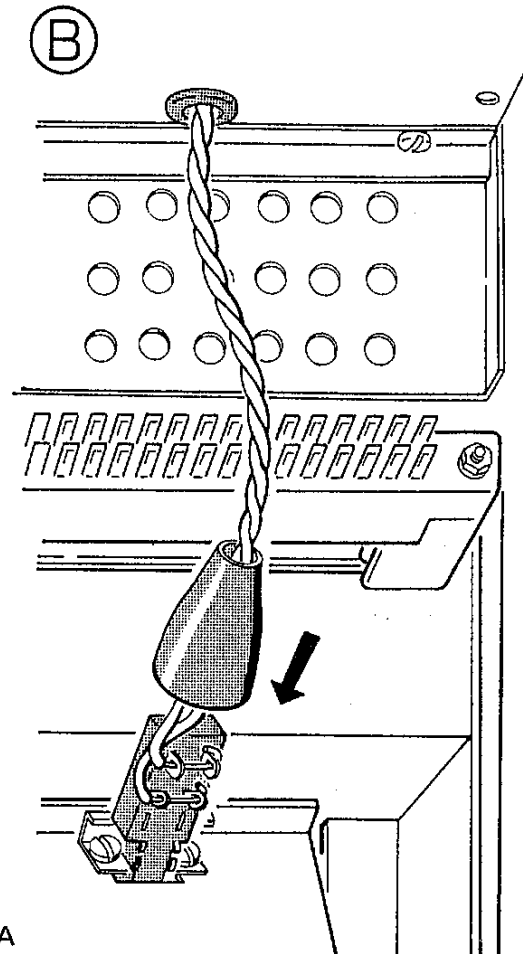

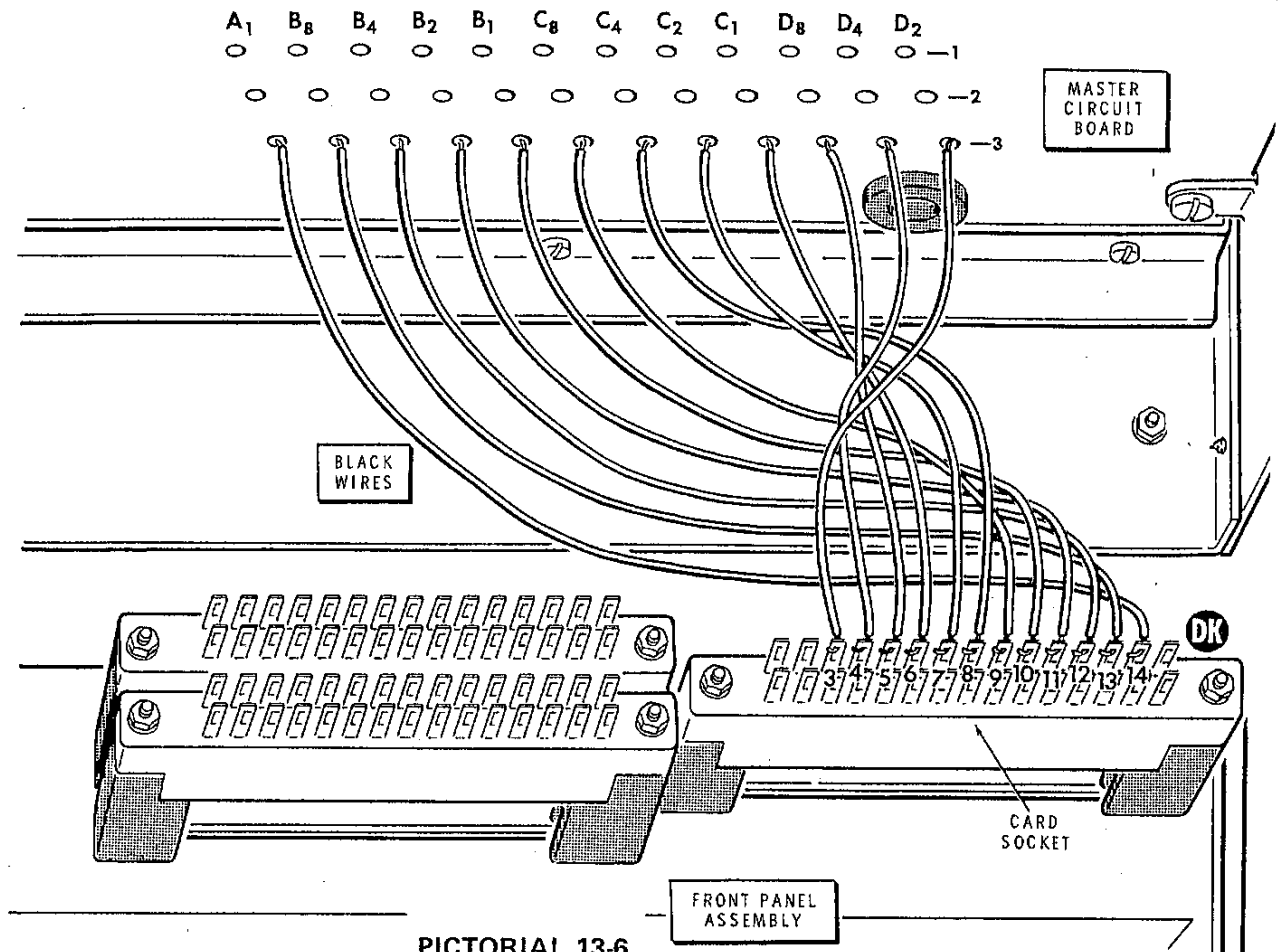

PICTORIAL 13-6

Card Socket Wiring

Refer to Pictorial 13-6 for the following steps.

- (/) Prepare twelve 11" lengths of small black stranded wire.

NOTE: When installing these wires in the following steps, solder one end of each wire to the side of the master circuit board the integrated circuits are mounted on. The other ends will be connected to card socket DK.

Install these twelve small black wires in the following steps:

	HOLE IN ROW 3 OF MASTER CIRCUIT BOARD	LUG OF CARD SOCKET DK
()	A ₁ (S-1)	14 (S-1)
()	B ₈ (S-1)	13 (S-1)

	HOLE IN ROW 3 OF MASTER CIRCUIT BOARD	LUG OF CARD SOCKET DK
()	B ₄ (S-1)	12 (S-1)
()	B ₂ (S-1)	11 (S-1)
()	B ₁ (S-1)	10 (S-1)
()	C ₈ (S-1)	9 (S-1)
()	C ₄ (S-1)	8 (S-1)
()	C ₂ (S-1)	7 (S-1)
()	C ₁ (S-1)	6 (S-1)
()	D ₈ (S-1)	5 (S-1)
()	D ₄ (S-1)	4 (S-1)
()	D ₂ (S-1)	3 (S-1)

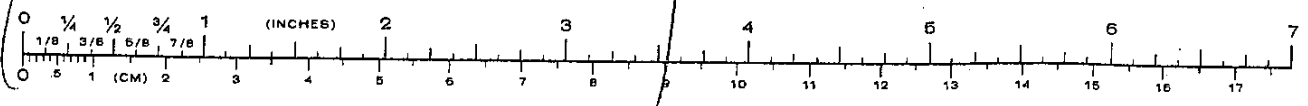

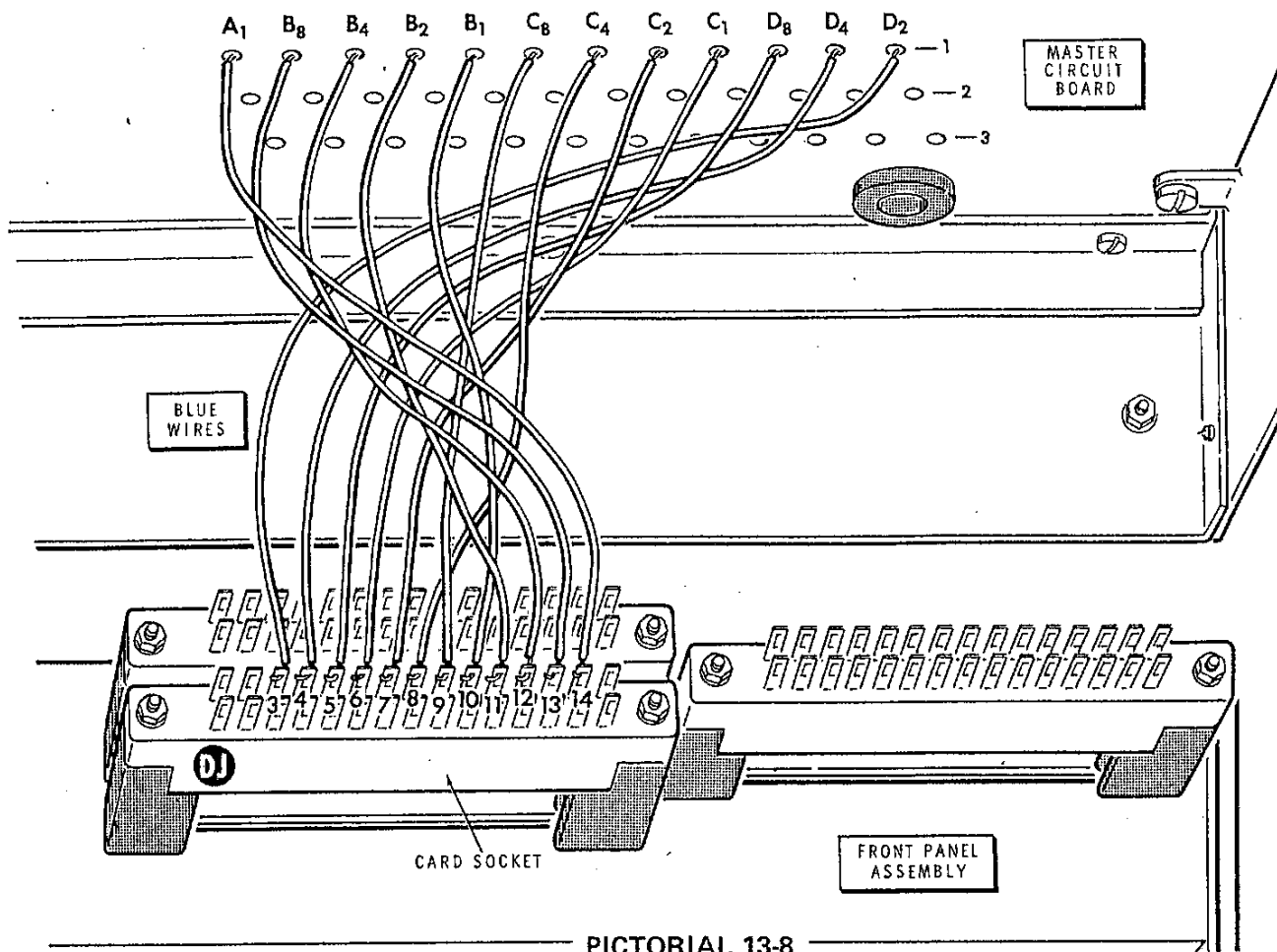

Refer to Pictorial 13-8 for the following steps.

- 1 Prepare twelve 11" lengths of the small blue stranded wire.

NOTE: When installing these wires in the following steps, solder one end of each wire to the side of the master circuit board the integrated circuits are mounted on. The other ends will be connected to card socket DJ.



Install these twelve small blue wires in the following steps:

HOLE IN ROW 1 OF MASTER CIRCUIT BOARD	LUG OF CARD SOCKET DJ
A ₁ (S-1)	14 (S-1)
B ₈ (S-1)	13 (S-1)
B ₄ (S-1)	12 (S-1)
B ₂ (S-1)	11 (S-1)
B ₁ (S-1)	10 (S-1)
C ₈ (S-1)	9 (S-1)
C ₄ (S-1)	8 (S-1)
C ₂ (S-1)	7 (S-1)
C ₁ (S-1)	6 (S-1)
D ₈ (S-1)	5 (S-1)
D ₄ (S-1)	4 (S-1)
D ₂ (S-1)	3 (S-1)

() Cut off the excess lead lengths from the master circuit board. Be sure that none of the card socket wires are touching each other.

() Refer to Part A of Detail 13-8A and position the wire tie around the black, orange, and blue wires coming from the card sockets. Then carefully pull the wire tie until it is tight around the wires as shown in Part B of the Detail. Cut off the excess length of the wire tie.

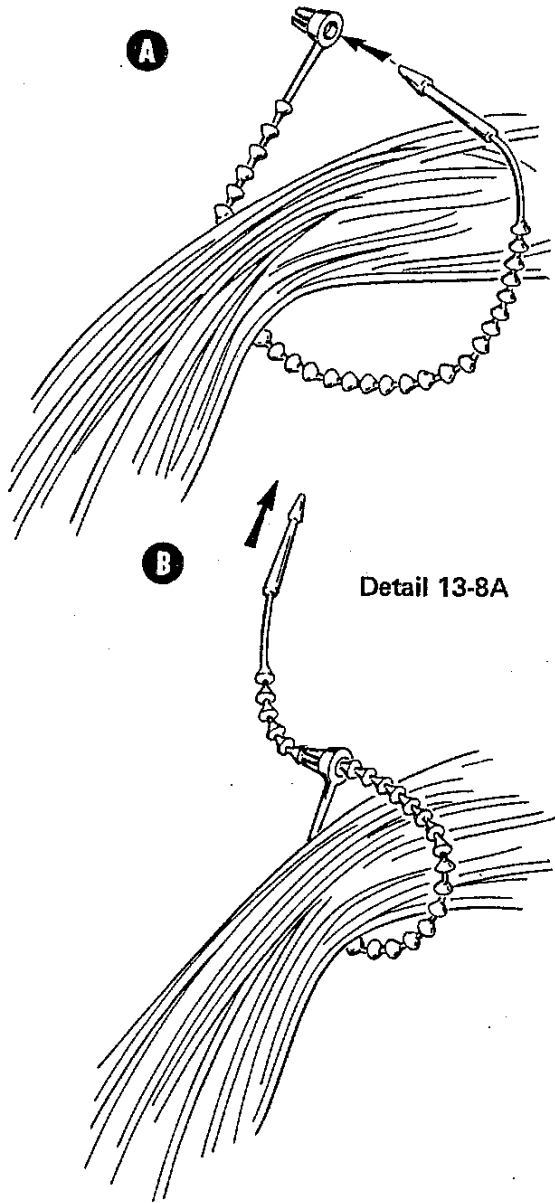

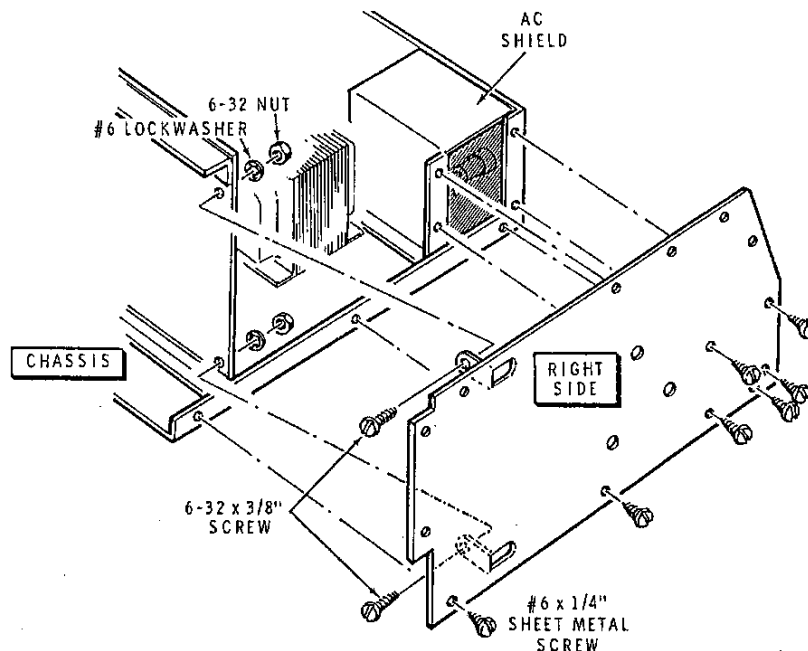

PICTORIAL 14-1

Refer to Pictorial 14-1 for the following steps.

- (✓) Mount the right side to the chassis as shown with seven #6 x 1/4" sheet metal screws.
- (✓) Use 6-32 x 3/8" hardware and mount the right side to the master circuit board. Be careful not to break off any of the wires connected to the card sockets.

Refer to Pictorial 14-2 for the following steps.

- (✓) Refer to Detail 14-2A and install the twenty-one buttons on the front panel switches. Install each button by setting it on the switch shaft and then pressing it firmly onto the switch. Securely hold the front subpanel while installing the buttons.
- (✓) Temporarily loosen the hardware holding 3-switch assembly CK to the front subpanel.
- (✓) Similarly loosen the hardware holding 5-switch assembly CL to the front subpanel.
- (✓) Loosen the hardware holding power switch CN to the front subpanel.

- (✓) Locate the trim panel and position it on a soft cloth under the front panel assembly as shown.
- (✓) Place a #8 flat washer on each mounting post of the trim panel as shown. The holes in the flat washers should be lined up with the holes in the mounting posts.
- (✓) Center the trim panel in the front panel assembly. Be sure the holes in the trim panel, #8 flat washers, and front panel assembly are lined up. Then mount the trim panel to the front panel assembly with 6-32 x 1/4" screws. NOTE: Do not overtighten the screws.
- () Position 3-switch assembly CK so the buttons are centered in the trim panel; then remove the trim panel and tighten the hardware holding the assembly.
- () Again center the trim panel and position 5-switch assembly CL so the buttons are centered in the trim panel. Then remove the trim panel and tighten the hardware holding the assembly.
- () Now center the trim panel and position Power switch CN so its button is centered in the trim panel. Then remove the trim panel and tighten the hardware holding the switch.

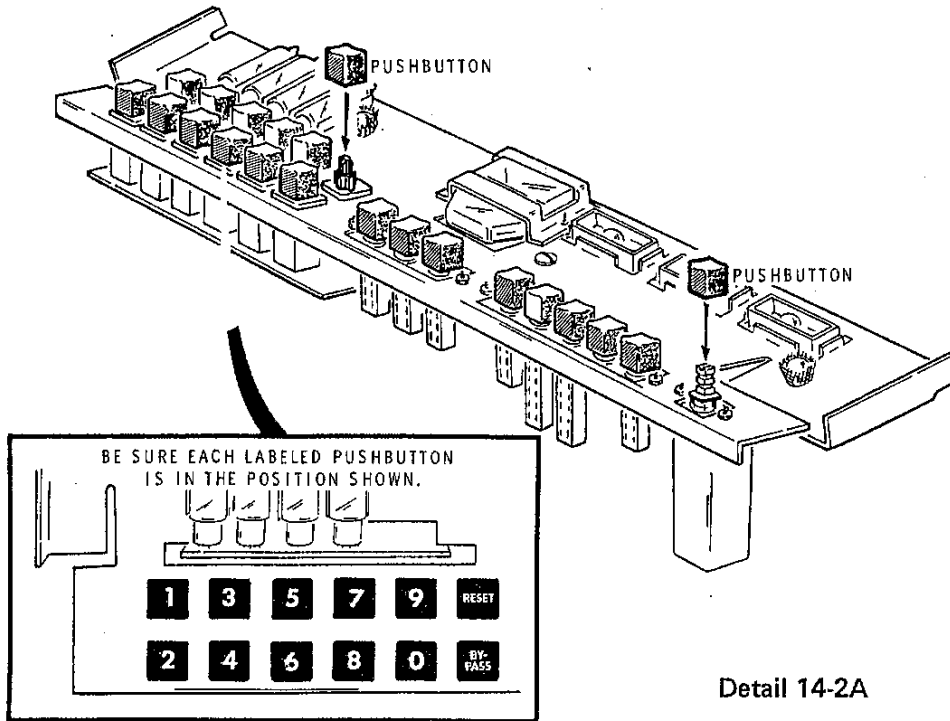
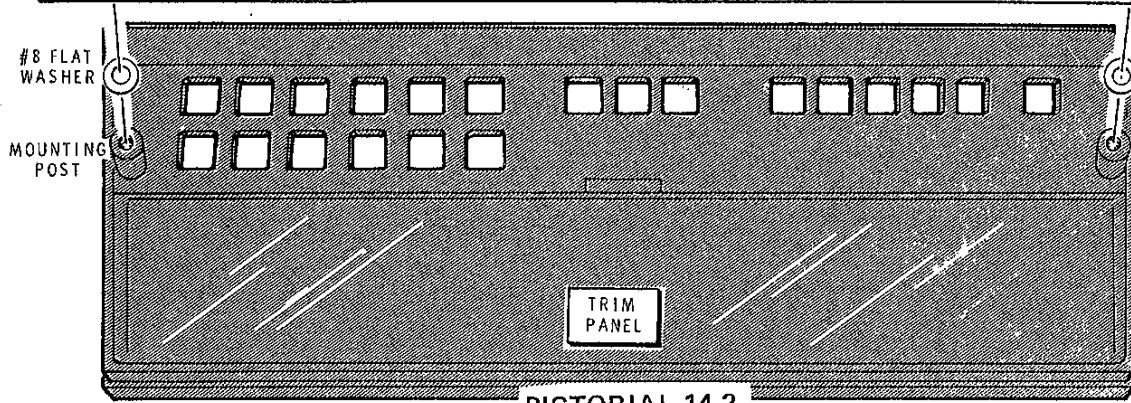
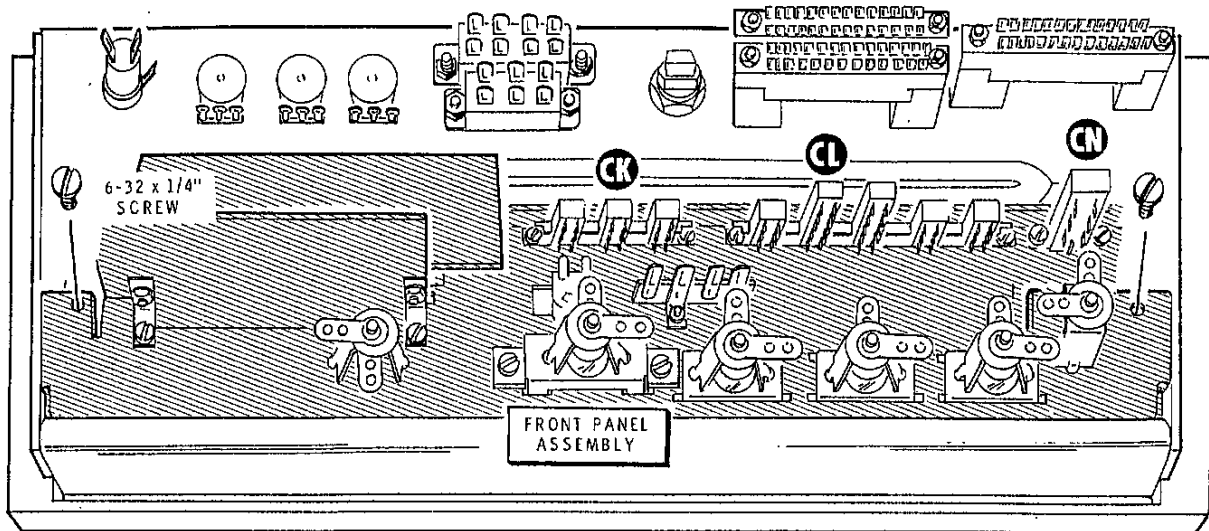



Refer to Pictorial 14-3 for the following steps.

- (✓) Peel away the backing paper and install the top rail label on the top rail as shown in the Pictorial. Be sure the label is positioned so it can be read from the front of the Tuner.
- (✓) Carefully fold the front panel assembly up to the chassis. NOTE: Position the wire harness, card socket wires, and Power switch wires so they will not get pinched. Then carefully fit the front panel assembly onto the chassis. The front panel assembly will temporarily be in this position to complete the remaining steps.

NOTE: The door can be opened and closed by lightly pressing on one of the corners. In one position the door is flush with the front panel, and in the other position the door is open slightly so it can be grasped for opening.

- (✓) Rotate the Auto-Sweep Speed control, Noise Squelch control, and the AGC Squelch control fully counterclockwise.

- (✓) Use the small allen wrench to start 4-40 x 1/8" setscrews in the round knobs.

NOTE: It will be easier to install the round knobs in the following steps if the setscrews are tightened to a point where the knob can just be slipped on the control shaft. Then tighten the setscrew.

- (✓) Install a round knob on each of the controls. Position the pointer of each knob as shown in the Pictorial.
- (✓) Carefully remove the front panel assembly from the chassis. Position the assembly face up in front of the chassis.

NOTE: The remaining parts and hardware will be used during the "Test and Adjustments" and "Final Assembly" sections of the Manual.

This completes the Step-by-Step Assembly section of the Manual. Carefully inspect the Tuner and all circuit boards for loose or unsoldered wires, and cold solder connections. Remove any wire clippings or solder splashes that may be lodged in the wiring. Then proceed with the "Tests and Adjustments" section of the Manual.

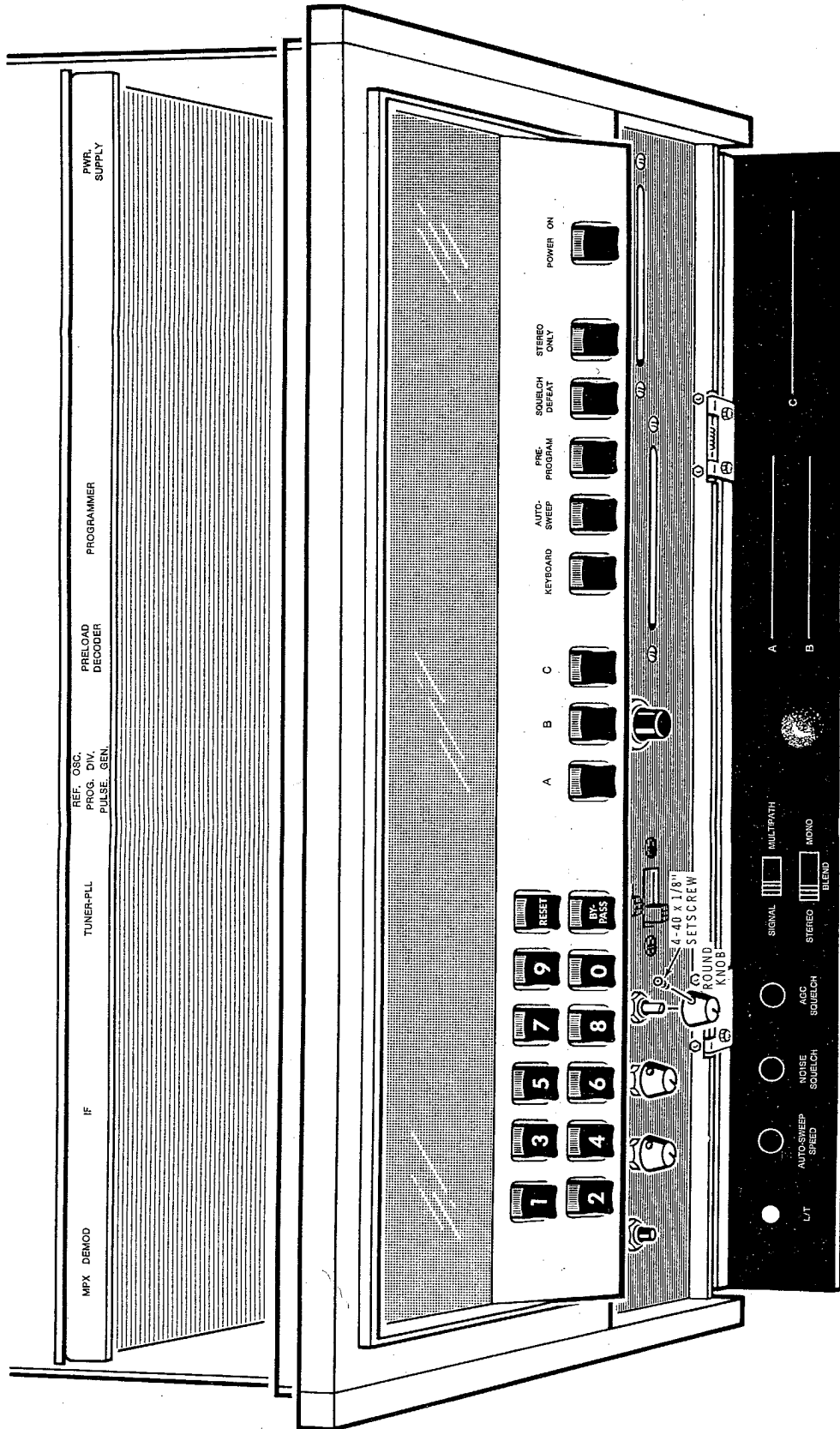

PICTORIAL 14-3

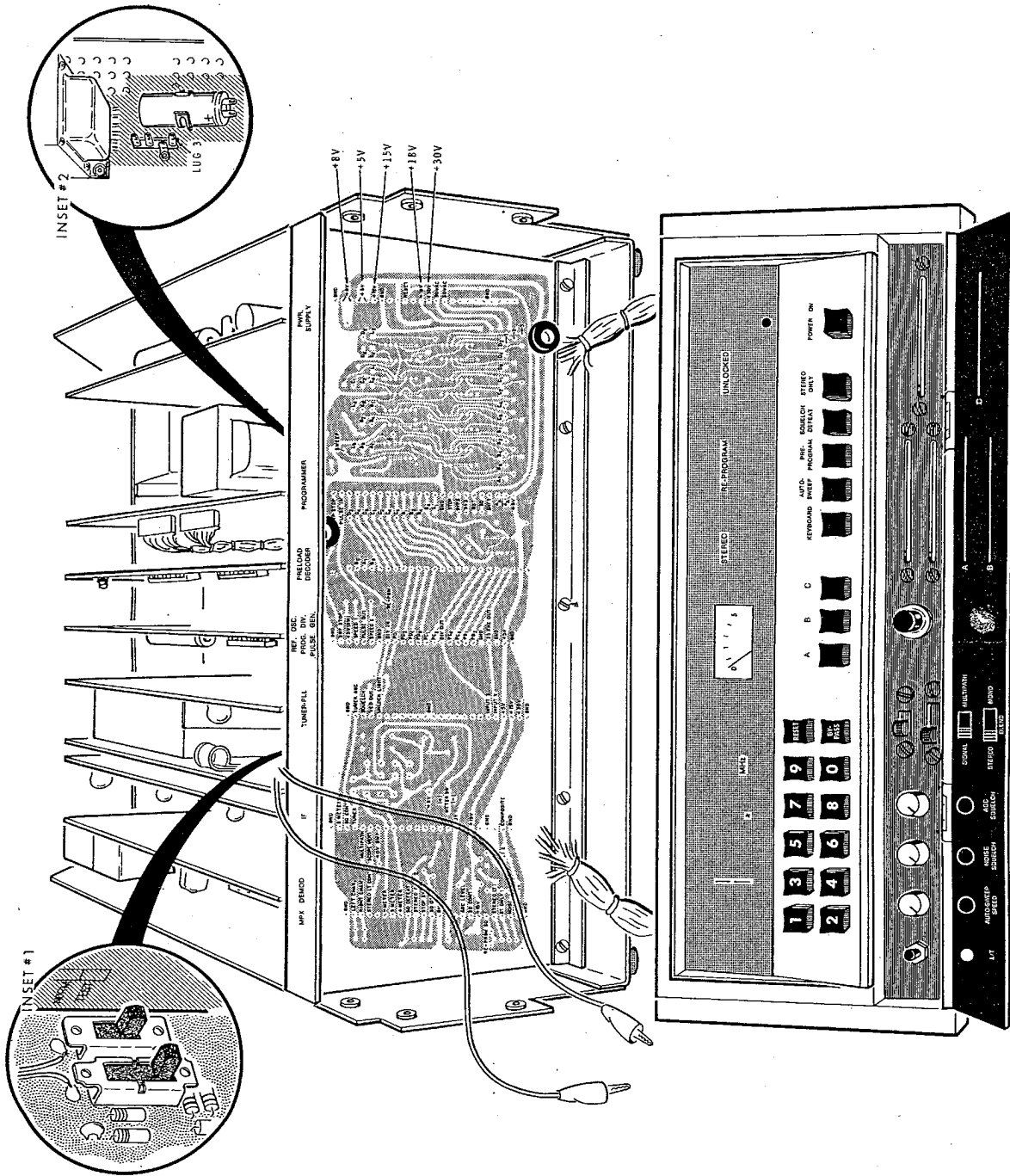

Figure 1-1

TESTS AND ADJUSTMENTS

The purpose of this section of the Manual is to make sure your Tuner will operate properly and that it will not be damaged as a result of a wiring error or some other difficulty. For example, a transistor could be destroyed instantly by a short circuit that causes excessive current. If you do not obtain the correct meter reading in any of the following steps, refer to the "In Case of Difficulty" section, Page 159.

The "In Case of Difficulty" section is divided into the five parts listed below. Each section contains a different type of

information to help you. After you locate and repair the difficulty, return to this section and complete the rest of the steps.

The "In Case of Difficulty" contains:

Visual Checks,
Troubleshooting Chart,
Bench Testing,
Checking Components,
Test Charts.

TESTS

NOTE: None of the plug-in circuit boards should be installed at this time.

Refer to Figure 1-1 (fold-out from Page 122) for the following steps.

- (✓) Position the front panel assembly and chassis as shown so you can watch the meter and operate the switches.
- () Open the front panel door and place the SIGNAL-MULTIPATH switch in the SIGNAL position.

TEST METER AND SECONDARY VOLTAGE CIRCUITS

- (✓) Locate the METER and RANGE switches, which are on the component side of the master circuit board, as shown in inset drawing #1.
- (✓) Set the METER switch to the TEST position.
- (✓) Set the RANGE switch to the OHMS position.

- (✓) Remove the test leads from their cable clamp.

NOTE: The Tuner was wired to operate from either a 120 Vac or 240 Vac power source. In the following steps, connect the Tuner to the ac power source for which it has been wired.

- (✓) Plug the power cord into an ac power source.
- (✓) Press the front panel POWER ON button to the ON (in) position. The meter should light up and indicate zero, and the MHz and power lamps should light. If the meter does not light up or indicate zero, press the POWER ON button to the off (out) position immediately and refer to the "In Case of Difficulty" section on Page 159.
- (✓) Connect the red and black test leads together. The meter should read as shown.





- (✓) Disconnect the red and black test leads. Then connect the black test lead to the chassis.
- (✓) Set the RANGE switch to the 50 Vdc position.
- (✓) Refer to Figure 1-1 and connect the red test lead to lug 3 of the terminal strip shown in inset drawing #2. The meter should read the following.



- (✓) Disconnect the test leads.

POWER SUPPLY CIRCUIT BOARD

If you do not get the correct meter reading in one of these "Power Supply Circuit Board" steps, refer to the "Trouble Reference. . ." column. This will refer you to a particular step (or two) in Test Chart 1 on Page 170. This Test Chart step will list several possible causes for your difficulty. (But

for tests on other circuit boards, refer to the general "In Case of Difficulty" instructions on Page 159.)

- (✓) Refer to Figure 1-2 and install the unused circuit board connector on the power supply circuit board.
- (✓) Set the RANGE switch to OHMS and perform the tests in the following chart.

NOTE: The circuit board connector pins line up with the lettering on the edge of the circuit board. When performing the following tests, be sure the test leads are connected to test pins that line up with the indicated lettering.

Hold the test leads on the indicated test pin until a stable meter reading is obtained. In some tests, the meter may initially deflect fully up scale or fully down scale and change to a stable reading. The final stabilized reading is shown for each test.

When you perform each test, look at the sample meter shown in the "Meter Should Read" column. Your meter reading should be within the shaded area.

CONNECT BLACK TEST LEAD TO:	CONNECT RED TEST LEAD TO:	METER SHOULD READ	TROUBLE REFERENCE ON TEST CHART 1
Heat sink for Q101.	Transistor mounting screw on Q101.		Step A.
Heat sink for Q104	Transistor mounting screw on Q104.		Step B.
Heat sink for Q108, Q109.	Transistor mounting screw on Q108. Transistor mounting screw on Q109.		Step C.
+8V IN pin	GND pin at either end of circuit board connector.		Step D.
+5V OUT pin			Step E.
+15V OUT pin.			Step F.
RESET pin	GND pin.		Step G.
+18V INPUT pin.	GND pin.		Step H.
+30V OUTPUT pin.	GND pin.		Step I.
AC INPUT pin.			Step J.
AC INPUT pin.			Step K.

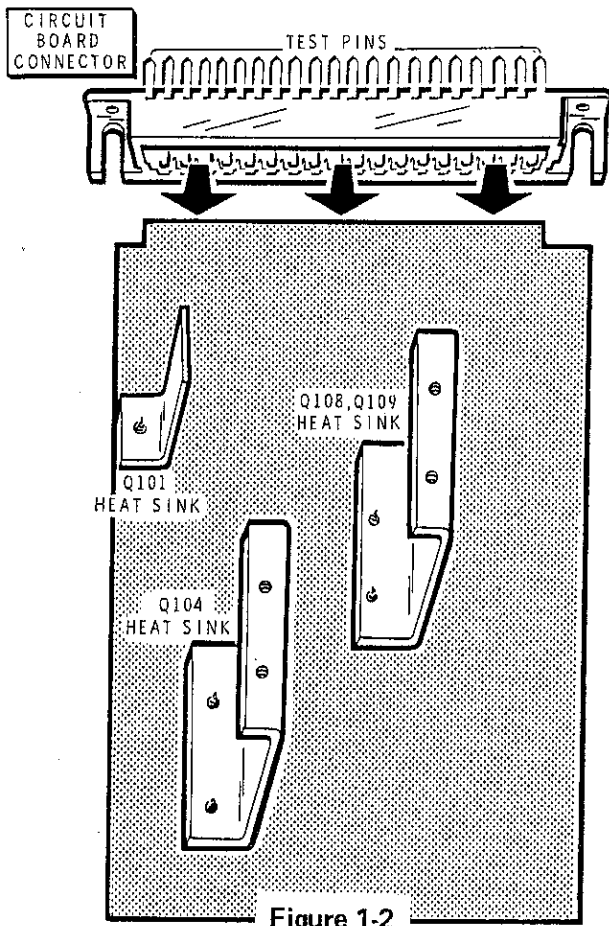

Figure 1-2

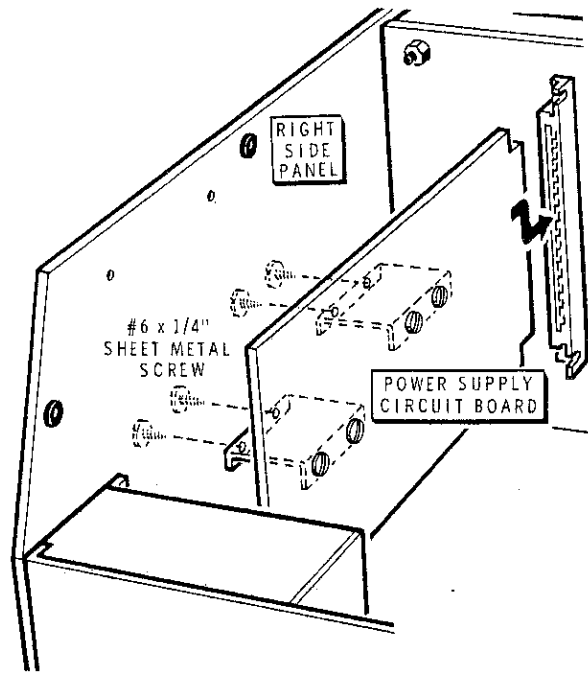

Figure 1-3

- (/) Press the POWER ON button to the off (out) position.
- (/) Set the RANGE switch to the 50V dc (center) position.
- (/) Remove the circuit board connector that was installed on the power supply circuit board.

- (/) Refer to Figure 1-3 and install the power supply circuit board in the circuit board connector on the master circuit board.
- (/) Again refer to the figure and mount the power supply circuit board to the right side of the chassis with four #6 x 1/4" sheet metal screws.
- (/) Press the front panel POWER ON button to the ON (in) position. The one (1) and the decimal point should now light.
- (/) Refer to Figure 1-1 (fold-out from Page 122) for test locations and make the measurements in the following chart.

CONNECT <u>BLACK</u> TEST LEAD TO:	CONNECT <u>RED</u> TEST LEAD TO:	METER SHOULD READ:	TROUBLE REFERENCE ON TEST CHART 1
Chassis	+30V		Step L.
	+18V		Step M.
	+15V		Step N.

() Set the RANGE switch to the 15V dc position.

CONNECT BLACK TEST LEAD TO:	CONNECT RED TEST LEAD TO:	METER SHOULD READ:	TROUBLE REFERENCE ON TEST CHART 1
Chassis	+5V		Step O.
	+8V		Step P.

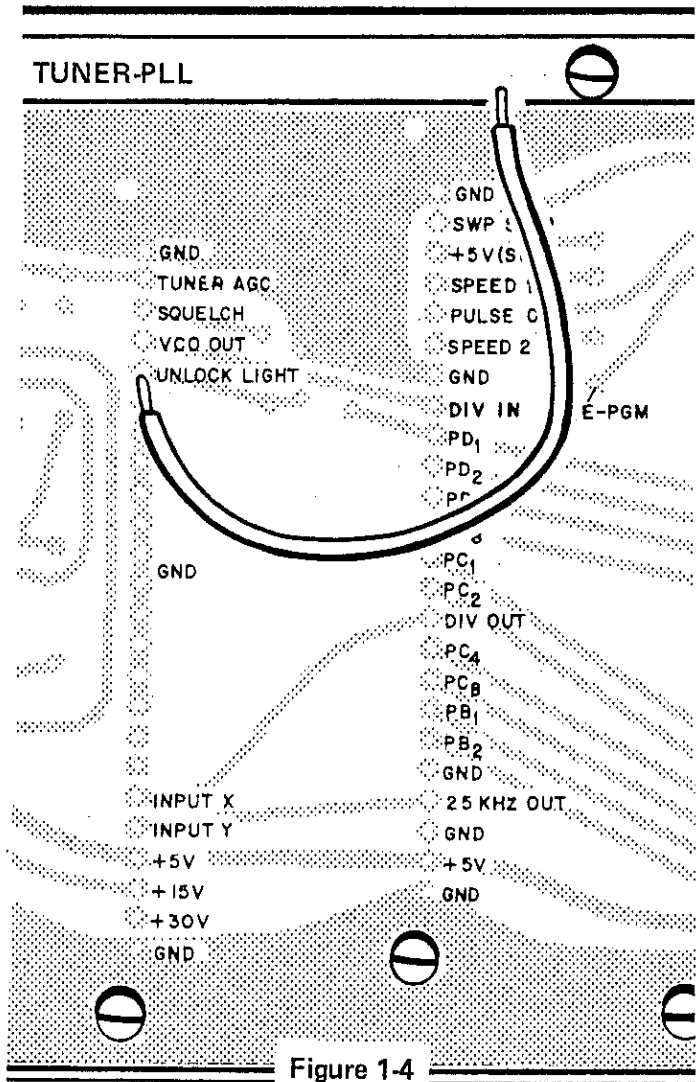
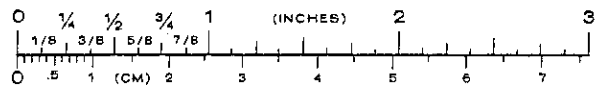

Figure 1-4

- () ✓ Disconnect the black test lead from the chassis.
- () ✓ Disconnect the red test lead.
- () ✓ Set the RANGE switch to the OHMS position.
- () ✓ Locate a piece of hookup wire that is two inches long or longer. Remove 1/4" of insulation from each end.
- () ✓ Refer to Figure 1-4 and hold one end of this wire against the metal part of the support rail. Then touch the other end of the wire to the UNLOCK LIGHT connection on the master circuit board. The UNLOCKED light on the front panel assembly should light up. If it does not light, check the connections to the unlocked light, and the lamp itself.
- () ✓ Press the red L/T (light/test) pushbutton switch behind the front panel door. The readout should be 188.8 MHz.

PROGRAMMER CIRCUIT BOARD

- () ✓ Install the circuit board connector on the programmer circuit board.
- () ✓ Make the measurements in the following chart. If any of your meter readings are incorrect, refer to the "In Case of Difficulty" section on Page 159.



CONNECT <u>BLACK</u> TEST LEAD TO:	CONNECT <u>RED</u> TEST LEAD TO:	METER SHOULD READ:
+5V	GND pin	
RST		
SQ		
The remaining pins-one at a time.		

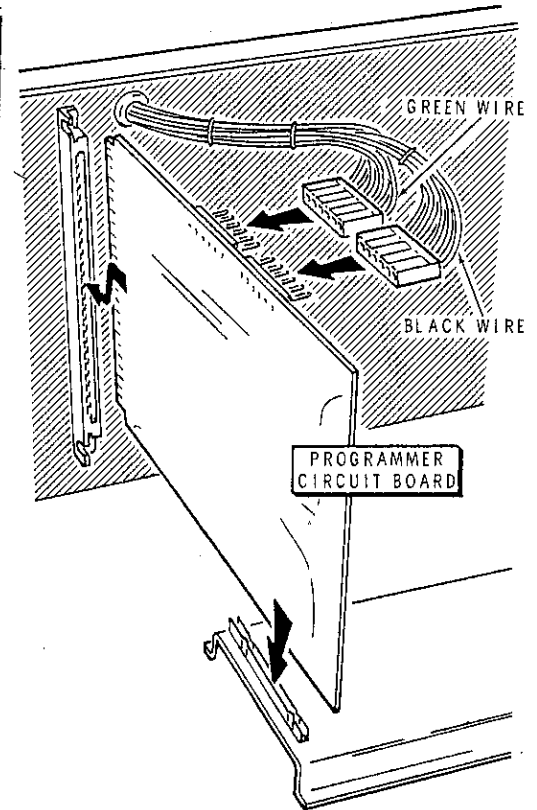

Figure 1-5

- (✓) Disconnect the red and black test leads.
- (✓) Press the POWER ON button to the off (out) position.
- (✓) Remove the circuit board connector that was installed on the programmer circuit board.
- (✓) Refer to Figure 1-5 and install the programmer circuit board. Then install the two plugs as shown.

NOTE: If you do not obtain the desired results in the following steps, refer to "Test Chart 11," Keyboard Circuit, on Page 183, and then to "Test Chart 2," Programmer and Data Multiplex Circuit, on Page 172.

- (✓) Press the POWER ON button to the ON (in) position.
- (✓) Press the KEYBOARD button to the on (in) position.
- (✓) Push the RESET button. The readout should read 00.1 MHz.
- (✓) Hold in the number 3 button, and then press and release the RESET button. The readout should be 133.3 MHz. Release the number 3 button.
- (✓) Hold in the number 6 button, and then press and release the RESET button. The readout should be 66.7 MHz. Release the number 6 button.
- (✓) Hold in the number 9 button, and then press and release the RESET button. The readout should be 199.9 MHz. Release the number 9 button.
- (✓) Press the RESET button. The readout should be 00.1 MHz.
- (✓) Press the number 1 button four times. The readout should be 111.1 MHz. Then press the RESET button.
- (✓) In the same manner as the number 1 button, press the remaining odd numbered buttons and the RESET button. The readout should be 33.3, 55.5, etc.
- (✓) In the same manner as before, press the even numbered buttons (except zero) and the RESET button. Note that the number to the right of the decimal point automatically changes to the next highest odd number. The readout should be 22.3, 44.5, etc.
- (✓) Press the AUTO-SWEEP button to the ON (in) position. The readout should read 107. blank MHz.

PRELOAD DECODER CIRCUIT BOARD

- () Install the circuit board connector on the preload decoder circuit board.
- () Make the measurements in the following chart. Be sure the RANGE switch is in the OHMS position. If any of your meter readings are incorrect, refer to the "In Case of Difficulty" section.

CONNECT <u>BLACK</u> TEST LEAD TO:	CONNECT <u>RED</u> TEST LEAD TO:	METER SHOULD READ:
Pin for A1	GND pin.	
Pin for +5V		
The remaining pins one at a time.		

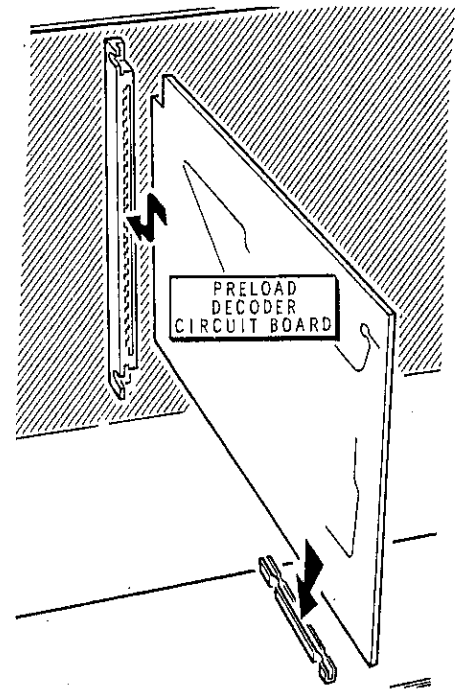

Figure 1-6

- (✓) Press the POWER ON button to the off (out) position.
- (✓) Remove the circuit board connector that was installed on the preload decoder circuit board.
- (✓) Refer to Figure 1-6 and install the preload decoder circuit board.
- (✓) Set the RANGE switch to the 15 Vdc position.
- (✓) Press the POWER ON button to the on (in) position.
- (✓) Press the KEYBOARD button to the ON (in) position and then press the RESET button. The REPROGRAM light should come on and the readout should be 00.1 MHz.
- (✓) Program 89.3 MHz by first pushing the 8 button then the 9 button then the 3 button. The readout should indicate 89.3 and the REPROGRAM light should go out.
- (✓) Refer to Figure 1-1 for test point locations and make the measurements in the following chart at or near the Preload Decoder location on the master circuit board. The readout should still be 89.3 MHz. If any of your meter readings are incorrect, refer to "Test Chart 12," Preload Decoder Circuit, on Page 186.

CONNECT <u>BLACK</u> TEST LEAD TO:	CONNECT <u>RED</u> TEST LEAD TO:	METER SHOULD READ:
Chassis	RE-PGM	
	B ₀	
	A ₁	
	B ₈	
	D ₂	

- (4) Refer to Figure 1-1 for test point locations and make the measurements in the following chart at the PROGRAMMER location on the master circuit board. The readout should still be 89.3 MHz. If any of your meter readings are incorrect, refer to "Test Chart 12," Preload Decoder Circuit, on Page 186.

CONNECT BLACK TEST LEAD TO:	CONNECT RED TEST LEAD TO:	METER SHOULD READ:
Chassis	D ₄	
	D ₆	
	C ₁	
	C ₂	
	C ₄	
	C ₆	
	B ₁	
	B ₂	
	+5V	

- (4) Refer to Figure 1-1 for test point locations and make the measurements in the following chart at the REF OSC, PROG DIV, PULSE GEN location on the master circuit board. The readout should still be 89.3 MHz. If any of your meter readings are incorrect, refer to "Test Chart 12," Preload Decoder Circuit, on Page 186.

CONNECT BLACK TEST LEAD TO:	CONNECT RED TEST LEAD TO:	METER SHOULD READ:
Chassis	PD ₁	
	PD ₂	
	PD ₄	
	PD ₆	
	PC ₁	
	PC ₂	
	PC ₄	
	PC ₆	
	PB ₁	
	PB ₂	
+5V		

GENERATOR-DIVIDER-OSCILLATOR CIRCUIT BOARD (GEN-DIV-OSC)

- (✓) Disconnect the red and black test leads.
- (✓) Set the RANGE switch to the OHMS position.
- (✓) Install the circuit board connector on the generator-divider-oscillator circuit board.
- () Make the measurements in the following chart.

CONNECT <u>BLACK</u> TEST LEAD TO:	CONNECT <u>RED</u> TEST LEAD TO:	METER SHOULD READ:
+5V	GND pin.	
+5V (SW)		
The remaining pins—one at a time (except GND).		

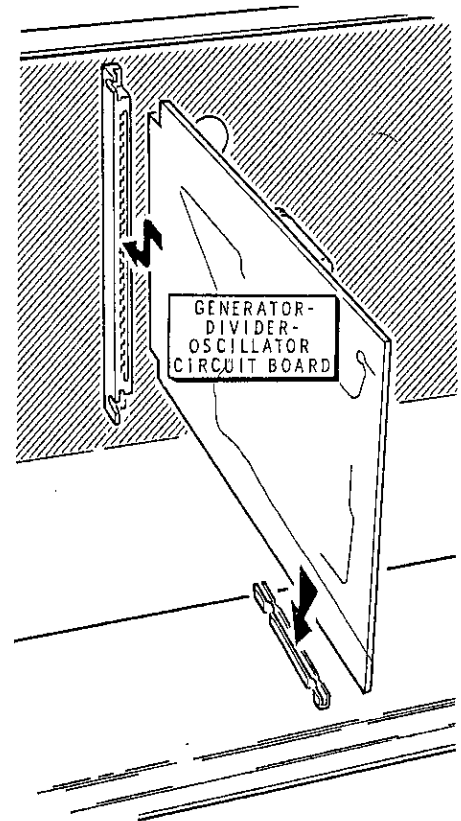

Figure 1-7

- (✓) Press the POWER ON button to the off (out) position.
- (✓) Remove the circuit board connector that was installed on the generator-divider-oscillator circuit board.
- (✓) Refer to Figure 1-7 and install the generator-divider-oscillator circuit board.
- (✓) Press the POWER ON button to the ON (in) position. The RE-PROGRAM light should light.
- (✓) Press the AUTO-SWEEP button to the ON (in) position. The readout should start at 107.9 MHz and count down by odd numbers (9, 7, 5, 3, 1, 9, etc.) to 88.1 MHz; then it should reset to 107.9 MHz and count down again.
- (✓) Rotate the AUTO-SWEEP SPEED control; this should vary the sweep rate.
- (✓) Press the RESET button. Each time you press this button, the readout should go to 107. blank MHz and count down again.
- (✓) Press the KEYBOARD button to the ON (in) position.

NOTE: If in the next step the readout should fail to count down, refer to "Test Chart 6," Auto-Sweep Pulse Generator circuit, on Page 179.

If the readout fails to count down in the proper sequence, fails to return to 107.9 after reaching 88.1, or the RE-PROGRAM light comes on, refer to the last half of "Test Chart 2," Programmer and Data Multiplex circuits, beginning on Page 172.

TUNER/PHASE-LOCK-LOOP CIRCUIT BOARD (TUNER-PLL)

- (✓) Set the RANGE switch to the OHMS position.
- (✓) Remove the extender cable from the circuit board cable.
- (✓) Install the circuit board connector on the tuner phase-lock-loop circuit board.

CONNECT BLACK TEST LEAD TO:	CONNECT RED TEST LEAD TO:	METER SHOULD READ:
TUNER AGC pin. SQUELCH pin. VCO pin. UNLOCK LIGHT pin. INPUT X pin INPUT Y pin	GND pin.	
+5V pin		
+15V pin		
+30V pin		

- (✓) Make the measurements in the above chart.
- (✓) Press the POWER ON button to the off (out) position.
- (✓) Remove the circuit board connector that was installed on the tuner/phase-lock-loop circuit board.

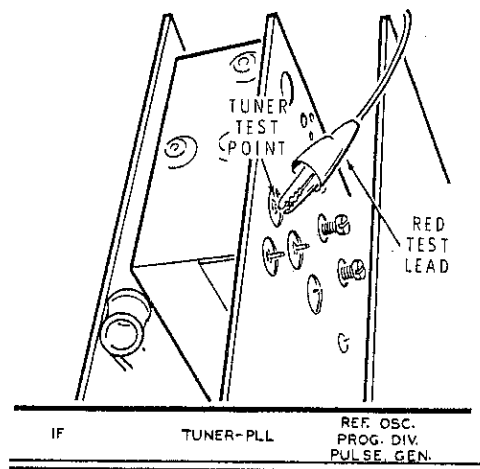

Figure 1-8

- (✓) Temporarily install the tuner/phase-lock-loop circuit board.

NOTE: If any of the following test conditions are not met, refer to Test Charts 7, 8, 9, and 10, on Pages 180 through 182.

- (✓) Press the POWER ON button to the ON (in) position.
- (✓) Press the KEYBOARD button to the ON (in) position.

- () Use the keyboard and program in 96.9 MHz. The RE-PROGRAM light should go out.
- (✓) Set the RANGE switch in the 15 Vdc position and make the following measurements on the master circuit board at the Tuner-PLL location.

CONNECT BLACK TEST LEAD TO:	CONNECT RED TEST LEAD TO:	METER SHOULD READ:
Chassis	VCO OUT	
	UNLOCK LIGHT	
	INPUT X	
	INPUT Y	

- () Disconnect the red test lead.
- (✓) Rotate the AUTO-SWEEP SPEED control (behind the front panel door) fully counterclockwise.
- (✓) Refer to Figure 1-8 and connect the red test lead to the tuner test point. Be sure the test lead does not touch any of the surrounding circuit board foil. The black test lead should still be connected to the chassis.
- (✓) Press the AUTO-SWEEP button to the ON (in) position. The meter indication will be near full scale and then move downward in small distinct moves as the readout sweeps down toward 88.1 MHz. When the readout cycles back to 107.9 MHz, the meter indication will again be near full scale.
- (✓) Press the POWER ON button to the off (out) position.
- (✓) Disconnect the red and black test leads.
- (✓) Press the POWER ON button to the ON (in) position.
- (✓) Press the PREPROGRAM button and one of the A, B, or C buttons to the ON (in) position. NOTE: No program card should be installed. The readout should read 1 - blank - blank - blank MHz. The RE-PROGRAM light and the UNLOCKED light should be on.
- (✓) Press the AUTO-SWEEP button to the ON (in) position. The RE-PROGRAM light should go out and the UNLOCKED light may flicker on and off as the readout counts down.

I-F CIRCUIT BOARD









- (✓) Install the circuit board connector on the i-f circuit board.
- (✓) Set the RANGE switch in the OHMS position.
- (✓) Make the measurements in the chart to the right of this step.
- (✓) Remove circuit board connector that was installed on the i-f circuit board.
- (✓) Temporarily set the I-F circuit board aside until it is needed for installation.

CONNECT <u>BLACK</u> TEST LEAD TO:	CONNECT <u>RED</u> TEST LEAD TO:	METER SHOULD READ:
SIGNAL METER pin	GND pin	
SQ CONT pin		
TUNER AGC		
SCOPE VERT pin.		
MULTIPATH pin.		
+0V SWP pin.		
+15V pin.		
COMPOSITE pin.		

MULTIPLEX CIRCUIT BOARD (MPX-DEM0D)

- () Install the circuit board connector on the multiplex circuit board.
- () Make the measurements in the chart that begins to the right of this step.

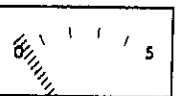
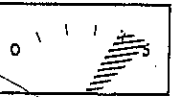
CONNECT <u>BLACK</u> TEST LEAD TO:	CONNECT <u>RED</u> TEST LEAD TO:	METER SHOULD READ:
GND pin	COMP pin.	
	ST ONLY 1 pin.	
	ST LT 1 pin.	

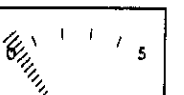
CONNECT BLACK TEST LEAD TO:	CONNECT RED TEST LEAD TO:	METER SHOULD READ:
GND pin	REPROG SQ pin	
	+15V pin.	
	AGC CONT pin.	
	AGC LEVEL pin.	
	+5V pin.	
	SQ OVRID pin.	
	STOP SW pin.	
	ST ONLY 2 pin.	
	SQ DEFEAT pin.	
	+ METER pin.	
	S MTR pin	
	-METER pin.	
	ST LT CONT pin.	
	R CHAN pin.	
L CHAN pin.		

(✓) Remove the circuit board connector that was installed on the multiplex circuit board.

(✓) Press the POWER ON button to the off (out) position.

(✓) Remove the tuner/phase-lock-loop circuit board that was installed earlier. The tuner/phase-lock-loop, i-f, and multiplex circuit boards will be installed during the following "Adjustments."

ADJUSTMENTS

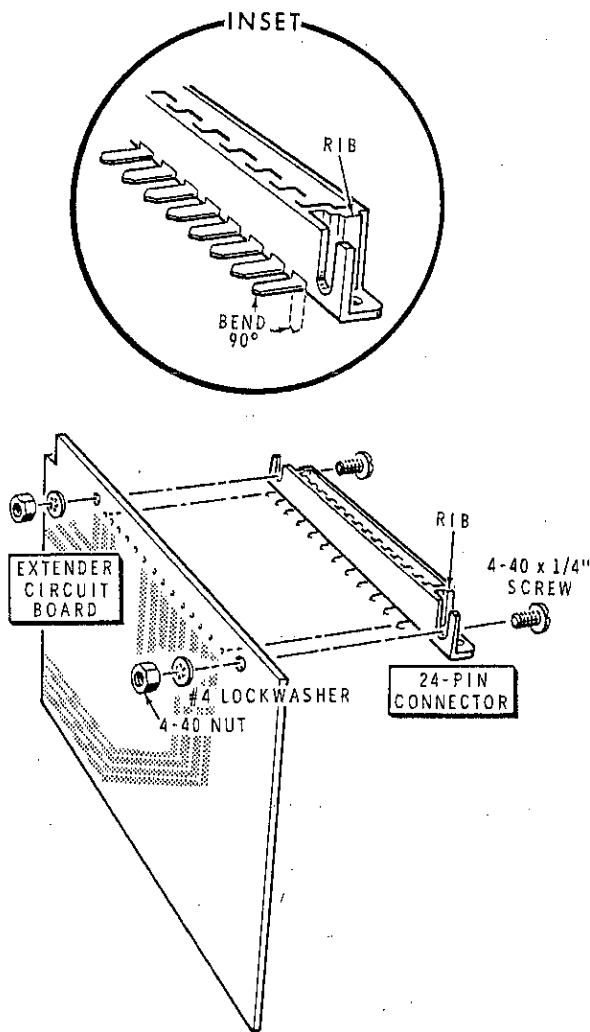

Figure 1-9

- () Refer to the inset drawing on Figure 1-9 and bend each pin on the circuit board connector as shown.
- () Mount the circuit board connector on the extender circuit board with 4-40 x 1/4" hardware as shown in Figure 1-9.
- () Solder each pin of the circuit board connector to the extender circuit board.
- () Refer to Figure 1-10 and install the extender circuit board in the tuner/phase-lock-loop circuit board location.

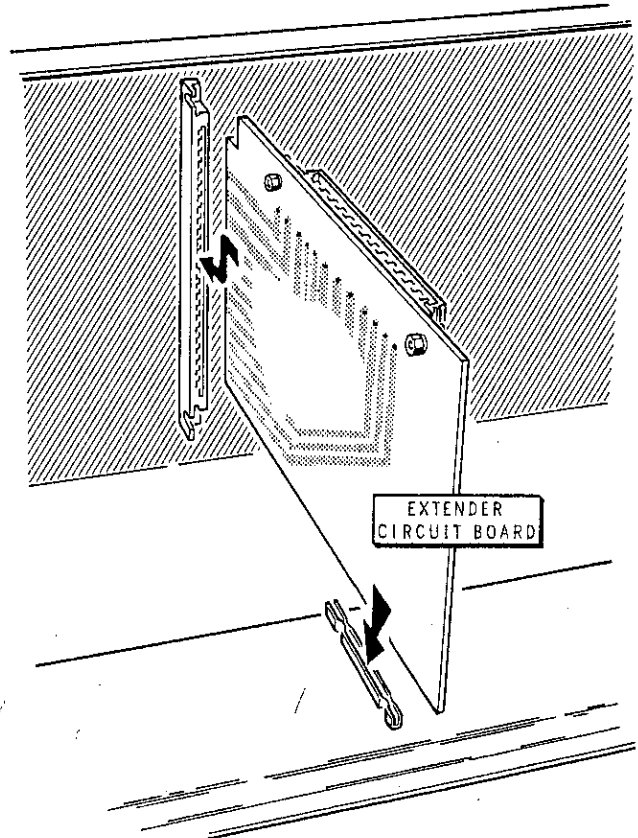

Figure 1-10

- (✓) Be sure the POWER ON button is in the off (out) position.
- (✓) Refer to Figure 1-11 (fold-out from Page 135) and install the i-f circuit board and the multiplex circuit board.
- (✓) Refer to Figure 1-12 and install the tuner/phase-lock-loop circuit board on the extender circuit board. Twist your antenna leads around the push-on connectors on the leads of the tuner/phase-lock-loop circuit board as shown. Do not disconnect the antenna leads until instructed to do so.
- (✓) Connect the extender cable from the tuner/phase-lock-loop board to the phono socket on the i-f circuit board.

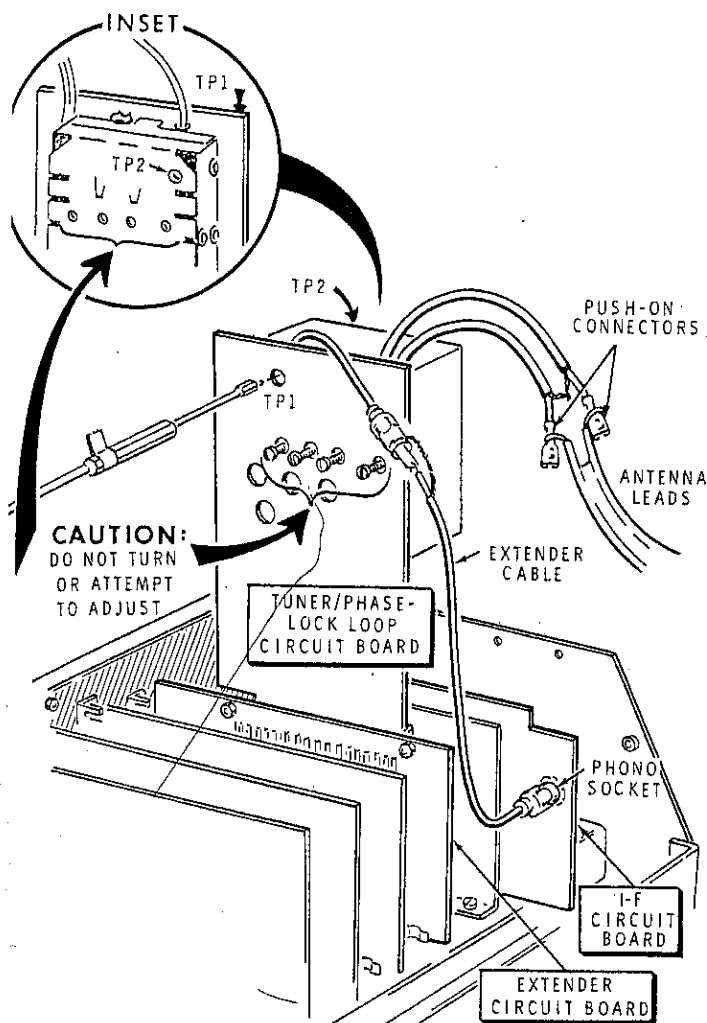

Figure 1-12

- (✓) Press the POWER ON button to the ON (in) position.
- (✓) Press the SQUELCH DEFEAT button to the ON (in) position.
- (✓) Set the METER switch in the NORM (normal) position.
- (✓) Be sure the AGC SQUELCH control is fully counterclockwise.
- (✓) Press the AUTO-SWEEP button to the ON (in) position.

- (✓) Rotate the AUTO-SWEEP SPEED control fully counterclockwise.
- (✓) Note the frequency of any station that gives a steady meter indication of between 3 and 4. It may be necessary to press the RESET button so the frequency and meter indication can be double checked.
- (✓) Press the KEYBOARD button and then program in the station frequency that gave the 3 to 4 meter indication.

CAUTION: Do not attempt to turn or adjust the tuner except as specified in the following steps. All adjustments, except those specified, are extremely critical and require sophisticated equipment and an intimate knowledge of alignment.

- (✓) Put a piece of tape around the tuning tool as shown in Detail 1-12A. This "flag" will show how far you have rotated the tuning tool.

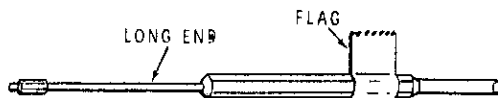

Detail 1-12A

- (✓) Use the tuning tool to rotate the slug at TP1 (not more than 1/4 turn) for a maximum meter reading.
- (✓) Rotate the slug at TP2 (not more than 1/4 turn) for a maximum meter reading.
- (✓) Repeat the two previous steps until there is no further improvement.
- () Press the POWER ON button to the off (out) position.
- () Remove the tuner/phase-lock-loop circuit board from the extender circuit board.
- () Remove the extender circuit board and reinstall the tuner/phase-lock-loop circuit board in the proper location.
- () Remove the i-f circuit board and install the extender circuit board in the i-f circuit board location.

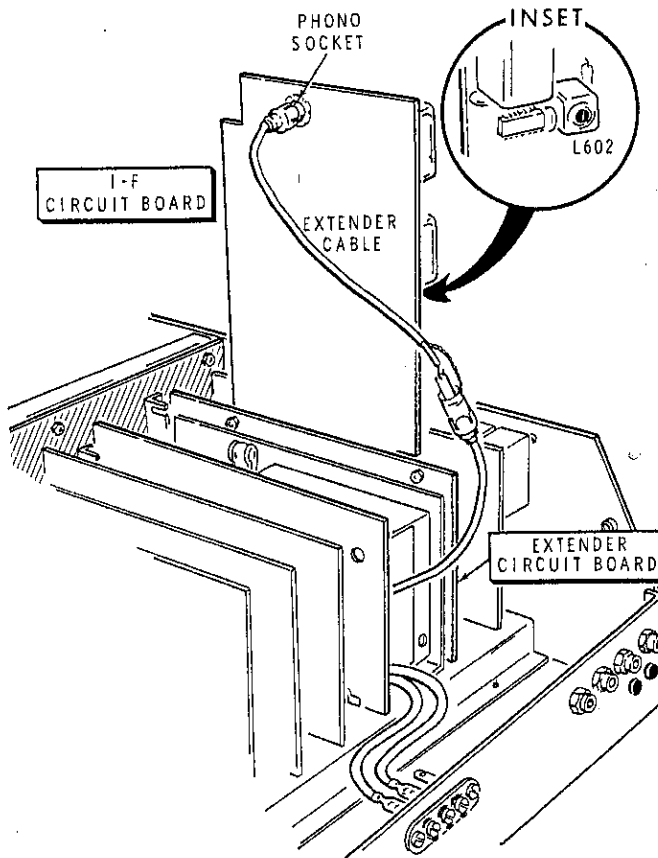

Figure 1-13

- () Refer to Figure 1-13 and install the i-f circuit board on the extender circuit board.
- () Locate the two audio cables supplied with the Digital Tuner.
- () Plug one end of one cable into the Tuner Outputs R (right) phono socket and the other end into the tuner input of your amplifier.
- () Plug one end of the remaining audio cable into the Tuner Outputs L (left) phono socket and the other end into the tuner input of your amplifier.
- () Turn on your amplifier system and adjust it so the audio signal from the Digital Tuner can be heard in the following steps.
- () Press the POWER ON button to the ON (in) position. Make sure the SQUELCH DEFEAT button and the KEYBOARD button are in the ON (in) position.
- () Program in the frequency of a local fm station by pressing the numbered buttons on the keyboard that correspond to the frequency.

- () Press the SQUELCH DEFEAT button to the off (out) position. The sound may go off.
- () Use the tuning tool to adjust L602 very slowly in either direction until the sound comes on again. Then, if you keep turning the tool in the same direction, the sound will go off again. Adjust L602 to the center of this "sound on" range.
- () Press the POWER ON button to the off (out) position.
- () Remove the i-f circuit board from the extender board.
- () Remove the extender board and reinstall the i-f circuit board in the proper location.
- () Unplug the extender cable from the i-f circuit board and the i-f cable. Then plug the i-f cable from the tuner-PLL circuit board into the phono socket on the i-f circuit board.
- () Press the POWER ON button to the ON (in) position.
- () Use the keyboard to program in a station broadcasting in stereo. NOTE: The STEREO light may come on.

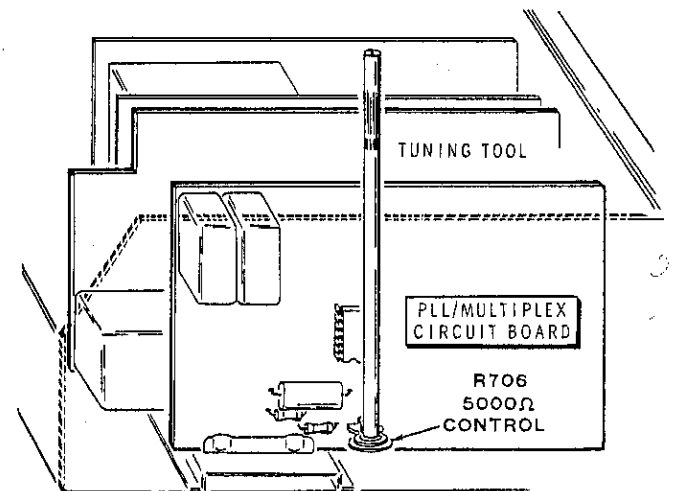
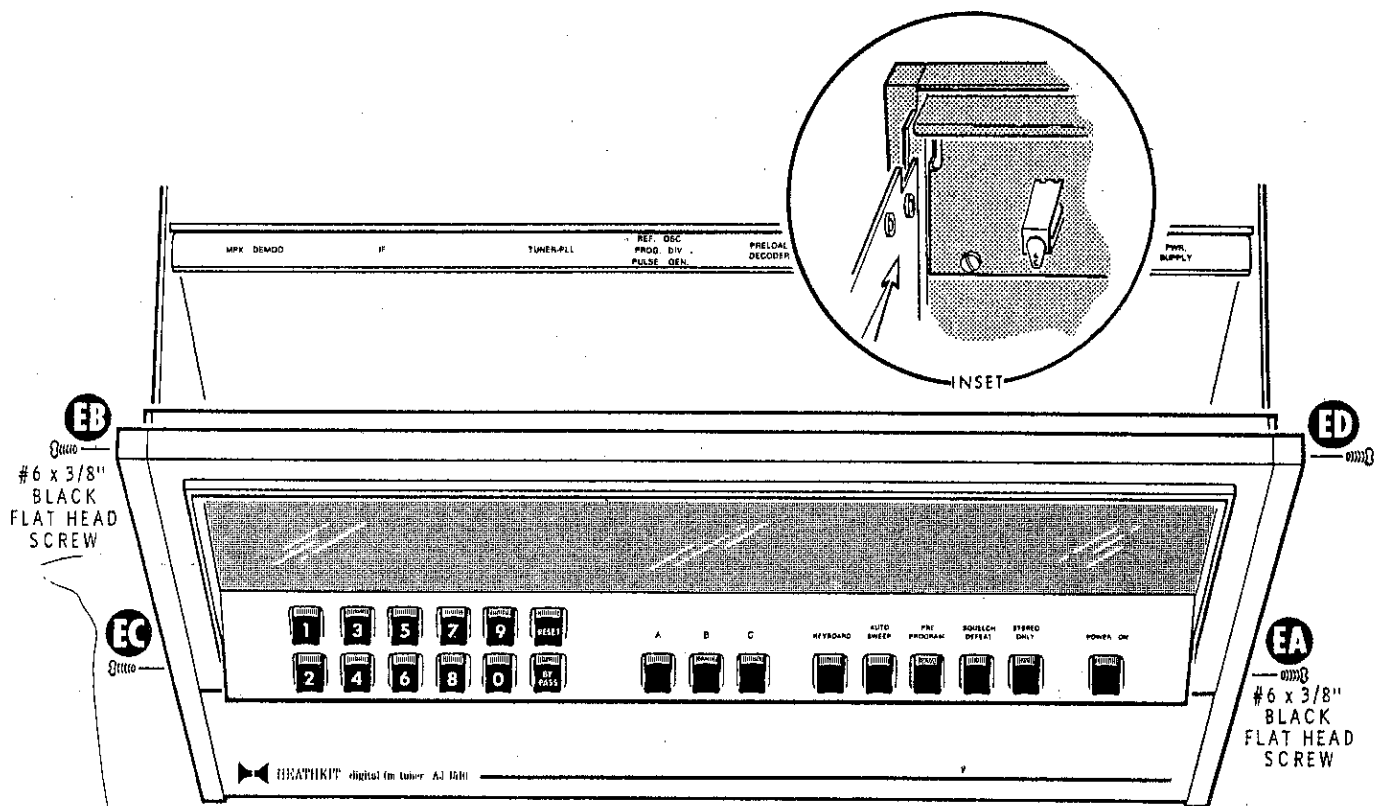

Figure 1-14

- () Refer to Figure 1-14 and adjust 5000 ohm control R706 (Sep Adj) very slowly in either direction until the STEREO light comes on. Then, if you keep turning the control in the same direction, the light will go out. Adjust control R706 to the center of the "light on" range.
- () Press the POWER ON button to the off (out) position. Then disconnect the antenna lead.

This completes the "Test and Adjustments." Proceed to the "Final Assembly" section.

FINAL ASSEMBLY



PICTORIAL 15-1

Refer to Pictorial 15-1 for the following steps.

NOTE: The parts used for this assembly section were left over from the "Front Panel" assembly section.

- () Set the METER switch to the NORM position.
- () Set the RANGE switch to the 50 V position.
- () Replace the test lead wires in their clamp.
- () Carefully fold the front panel assembly up to the chassis. NOTE: Position the wire harness, card socket wires, and Power switch wires so they will not get pinched. Then carefully fit the front panel assembly onto the chassis.
- () Use #6 x 3/8" black flat head screws at EA, EB, EC, and ED to mount the front panel assembly to the chassis. NOTE: Be careful that no wires were pinched between the sheet metal.

Refer to Pictorial 15-2 (fold-out from Page 141) for the following steps. NOTE: In the following step, position the blue and white identification label over the line voltage box which does not apply.

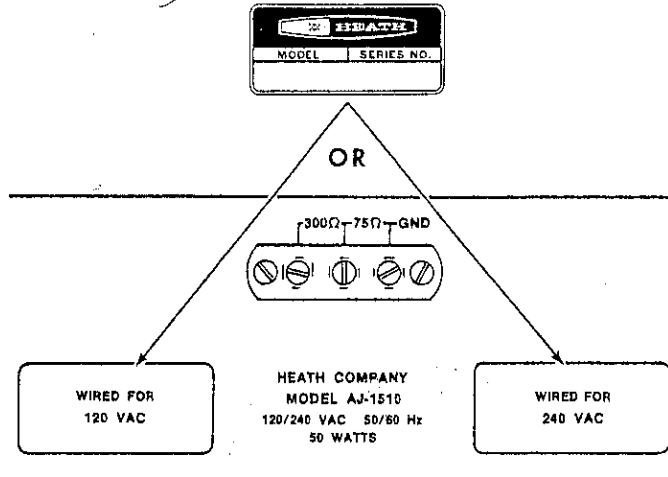

Detail 15-2A

() Carefully peel away the backing paper from the blue and white identification label. Then refer to Detail 15-2A and press the label onto the chassis over the line voltage box ("Wired for 120 Vac," or, "Wired for 240 Vac") that represents the way you did not wire this kit. Be sure to refer to the numbers on this label in any communications you have with the Heath Company about this kit.

() Locate the Certification label and sign and date it. Then remove the backing paper and press the label to the rear panel in a convenient location.

() Cut off two 2" lengths of the flat braid.

() Refer to Detail 15-2B and solder a #6 solder lug onto both ends of each length of braid.

Refer to Detail 15-2C for the following steps.

() Use a 6-32 x 1/4" screw to mount one end of a prepared braid at FB on the tuner on the tuner/phase-lock-loop circuit board. Fasten the other end of the braid to the rf shield at FC with a 6-32 x 1/4" screw and a 6-32 nut.

() Mount one end of the remaining braid to the tuner at FD with a 6-32 x 1/4" screw. The other end of the braid will be installed later.



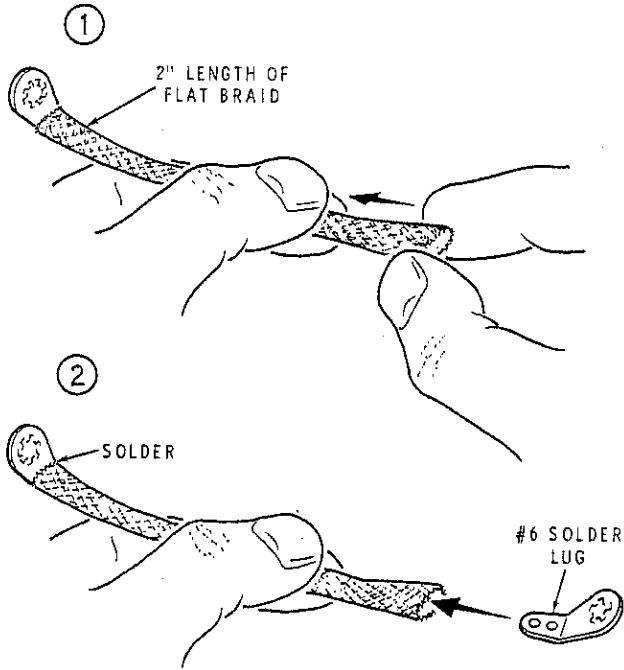

Detail 15-2B

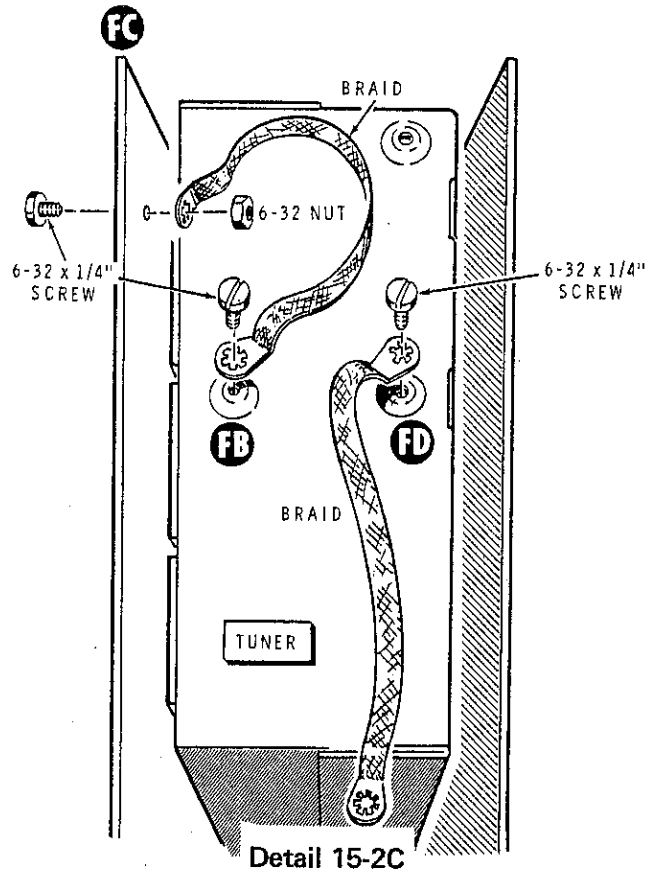

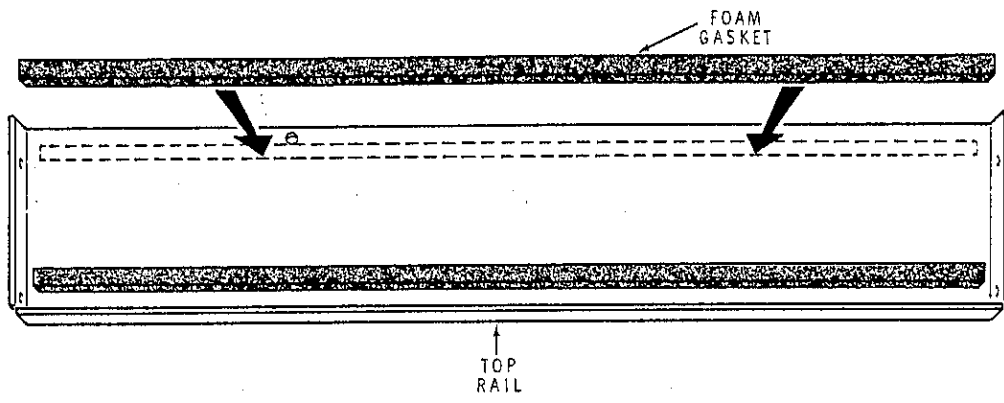

Detail 15-2D

Refer to Pictorial 15-2 for the following steps.

- () Cut two 14-1/2" lengths of the foam gasket material.
- () Refer to Detail 15-2D and remove the paper backing from the foam gasket material. Install this foam gasket as shown on the underside of the top rail. Be sure you install it on the correct side. NOTE: Be very careful you do not remove the adhesive along with the paper backing.
- () Position the top rail on the chassis as shown in Detail 15-2E. Then mount the free end of the braid coming from FD on the tuner to the top rail at FE with a 6-32 x 1/4" screw and a 6-32 nut.
- () Carefully press the top rail into position on the chassis as shown in Detail 15-2F. Then mount the top rail to the chassis with four #6 x 1/4" sheet metal screws.
- () Connect the antenna push-on connectors from the tuner-PLL circuit board to the screw-type terminal strip as shown in the Pictorial.

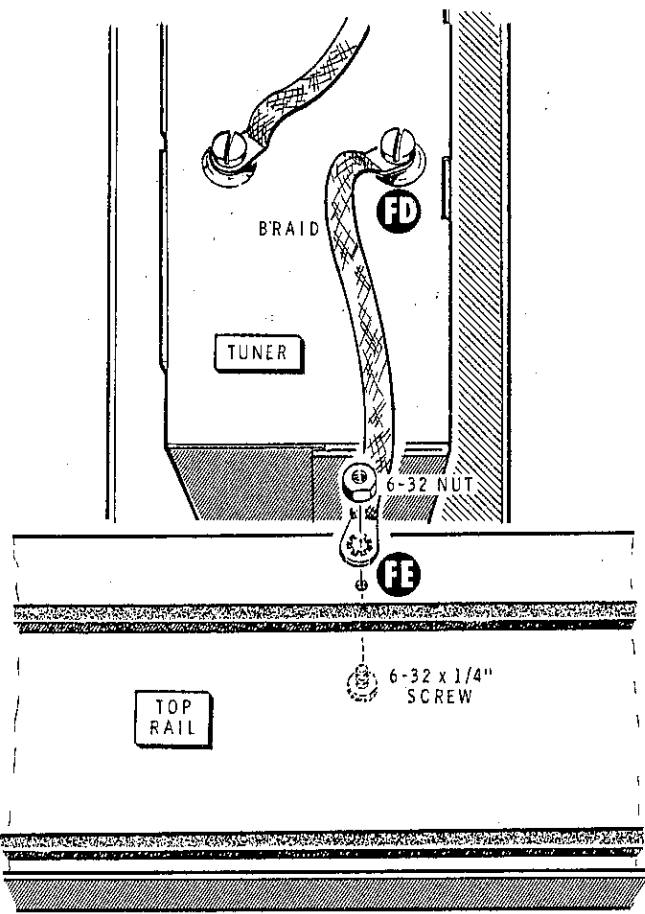

Detail 15-2E

Refer to Pictorial 16-1 for the following step.

- () Position the top shield on the tuner as shown, being careful not to pinch any wires.
- () Mount the top shield to the tuner with six 6-32 x 3/8" black flat head screws.

This completes the "Final Assembly." Proceed to the "Installation" section that follows.



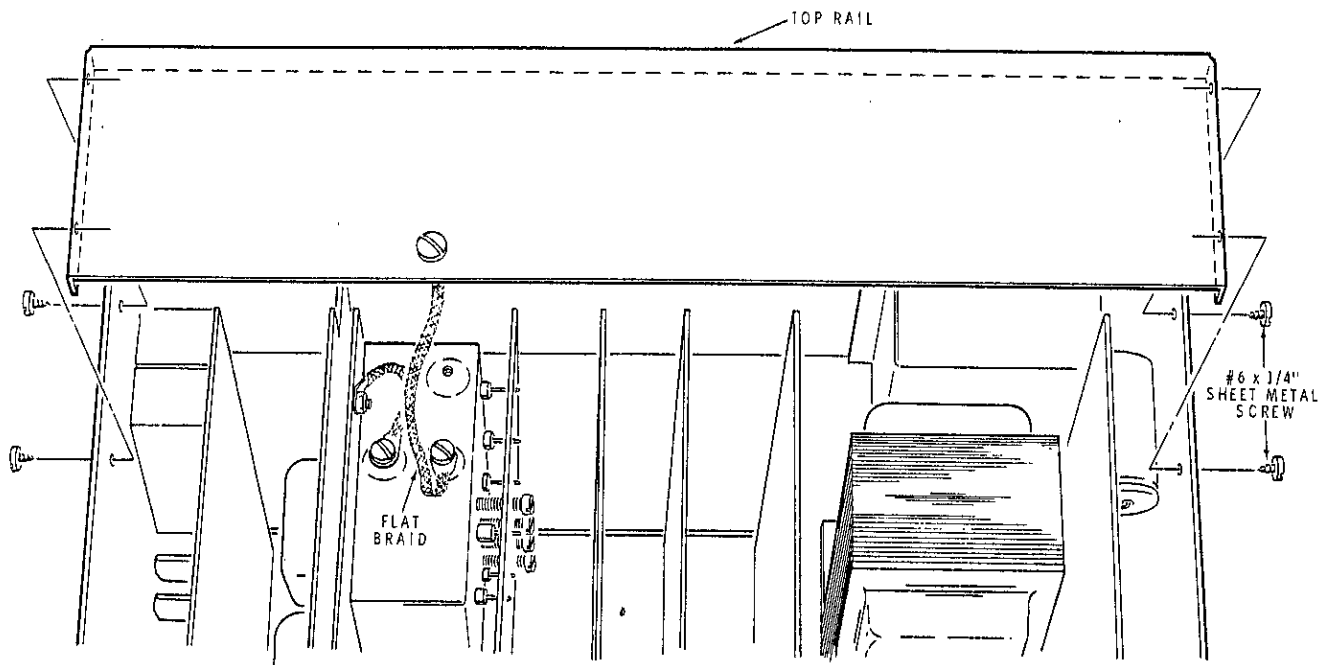

Detail 15-2F

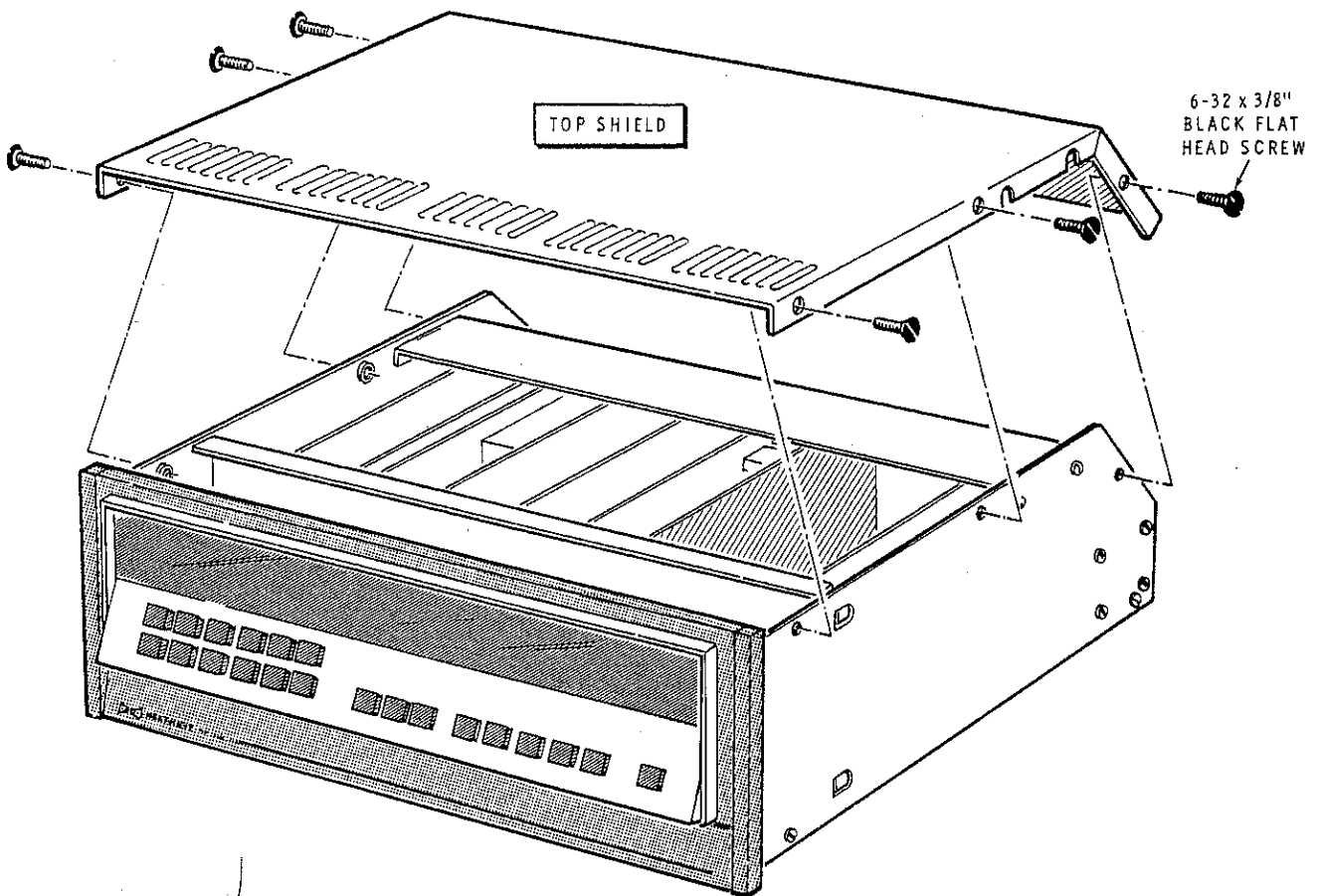

PICTORIAL 16-1



L

INSTALLATION

ACCESSORY CABINET INSTALLATION

Refer to Figure 2-1 for the following steps.

NOTE: If you have the accessory cabinet, complete the following steps. Otherwise proceed to "Systems Connections."

- () Position the Digital Tuner right side up on your work surface. Slide the cabinet over the unit so the front edge slides into the front panel assembly.
- () Install mounting plates on the back edges of the cabinet with #6 x 3/4" wood screws.

- () Fasten the plates to the Digital Tuner with #6 x 1/4" sheet metal screws.

This completes the accessory cabinet installation. Proceed to the "System Connections."

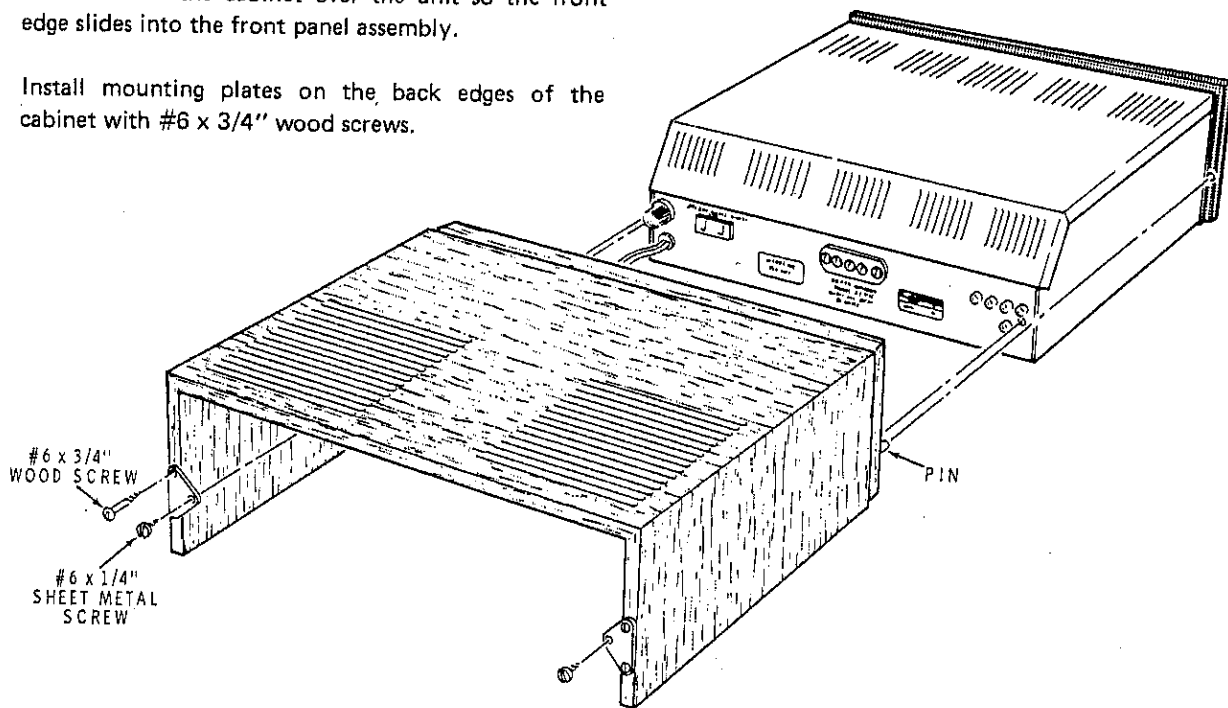

Figure 2-1

SYSTEMS CONNECTIONS

Refer to Figure 2-2 (fold-out from Page 142) before you connect the antenna, amplifier, or tape recorder to your Tuner.

INDOOR ANTENNAS

Several types of indoor TV and fm antennas are available that will provide satisfactory monaural fm operation of the Tuner in strong signal areas, or from local stations. For stereo fm reception, however, an outdoor antenna should be used.

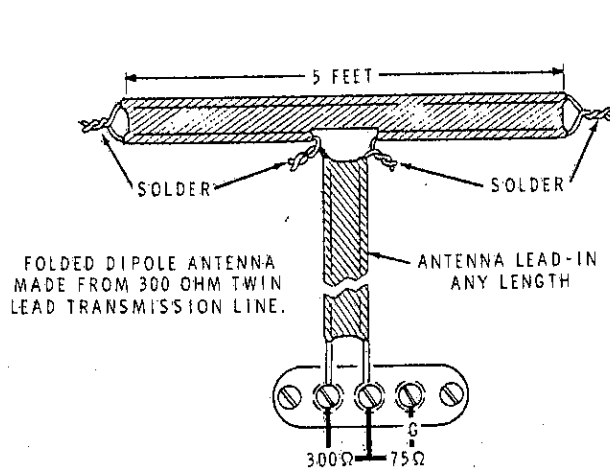

Figure 2-3

A simple folded dipole antenna can be made as shown in Figure 2-3 from vhf 300 Ω twin lead. This antenna can be placed on the rear of a large cabinet or nailed or stapled to a piece of wood to reinforce it. Best reception will be obtained from the stations that are broadside to this antenna. Weakest reception will occur with those stations that face the ends of the antenna.

OUTDOOR ANTENNAS

In weak signal areas, an outdoor antenna is necessary. Best reception will be obtained with a commercial fm outdoor antenna, but many television antennas are designed for fm usage as well as for TV reception. Be sure to check this

feature before purchasing a separate fm antenna. A vhf TV antenna can also be used as an fm antenna, since fm station frequencies are actually located between the TV frequencies for Channels 6 and 7.

Do not connect a TV antenna to both the TV set and the Tuner at the same time unless a TV antenna coupler is used, or a weak and distorted signal may occur in both units. Pad-type couplers are not recommended because large amounts of signal are lost in them. Use a preamplifier type of coupler instead, in which there is no loss of signal.

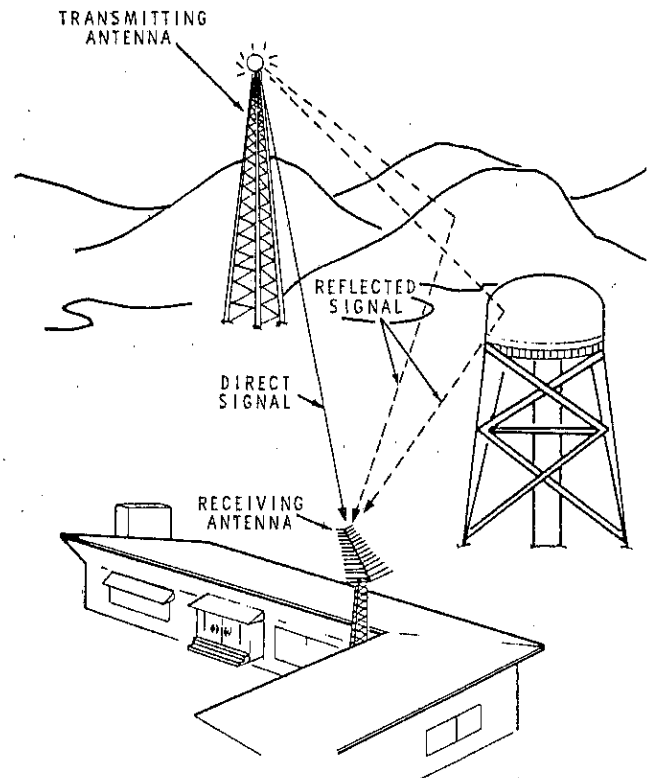

Figure 2-4

MULTIPATH SIGNALS

FM signals sometimes become noisy or distorted because they are reaching your antenna from several directions at the same time. See Figure 2-4. These multipath signals are usually reflected from objects such as large buildings, metal structures, mountains, and so on. You can usually eliminate or minimize this type of distortion by turning your antenna until it is receiving only one of these signals.

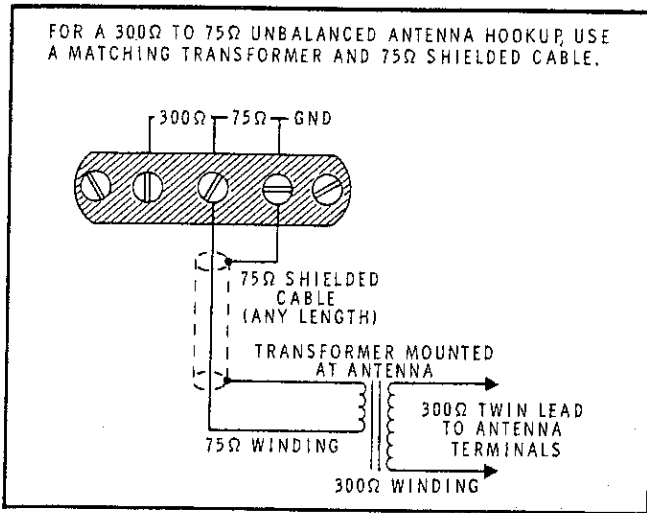

Figure 2-5

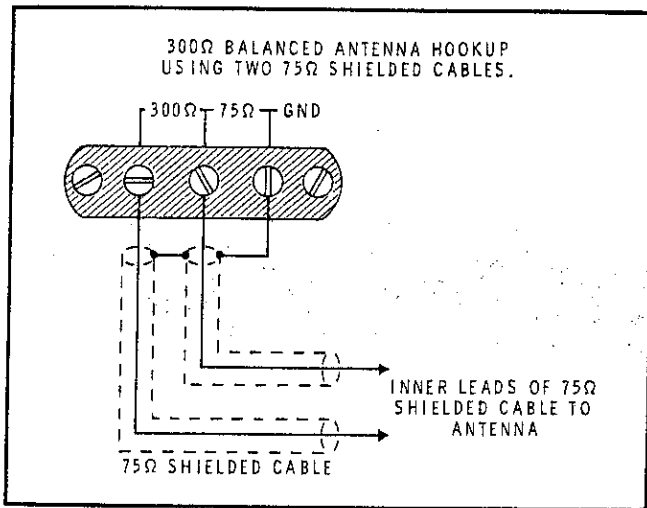

Figure 2-6

Unwanted reflected signals may also be picked up on your antenna lead-in wire in strong signal areas. To eliminate this condition, connect your antenna lead-in to the antenna terminal strip as shown in Figure 2-5 or 2-6. For more information on this subject, refer to the "Multipath Signal" section on Page 155.

OUTPUT CONNECTIONS

See Figure 2-7. Shielded cables, terminated in standard phono plugs, should be used for all output signal connections from your Tuner.

WIRING A PHONO PLUG

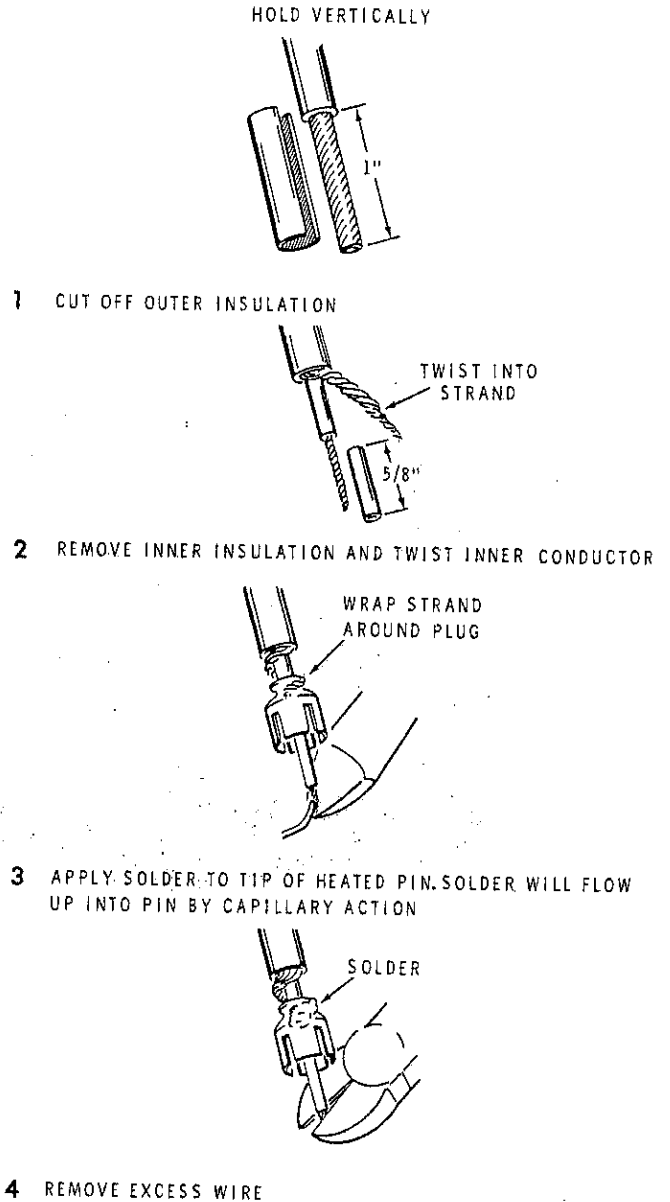

Figure 2-7

AC OUTLET

Power for other devices, such as tape decks or turntables, is available on the tuner rear apron. The power receptacle provides unswitched ac power of the same voltage as that supplied to the tuner. This outlet is rated at 350 watts maximum.

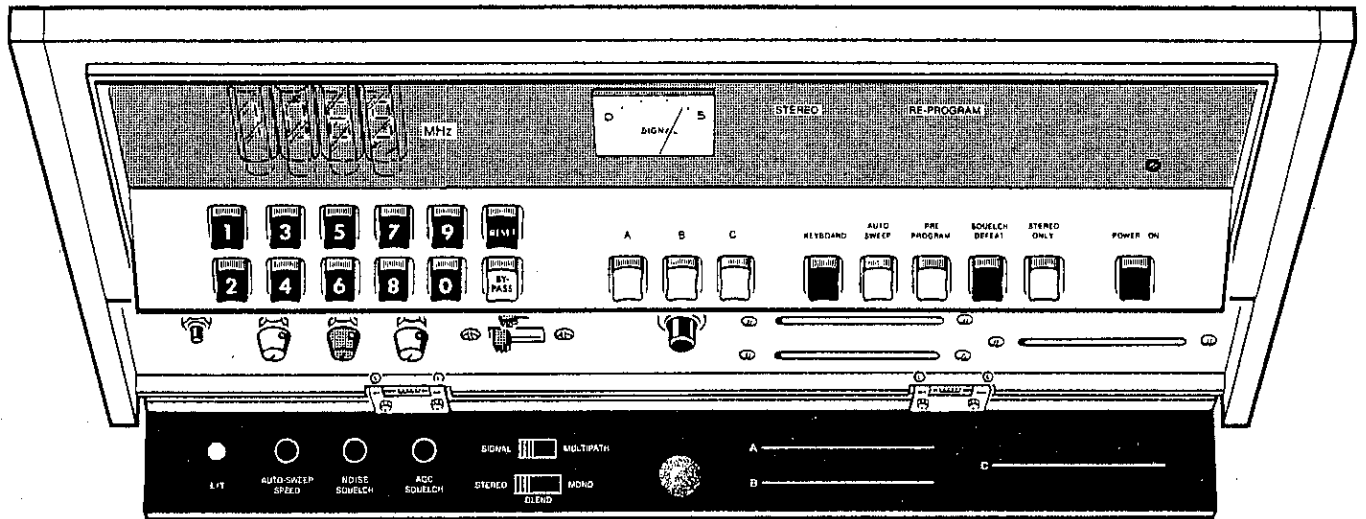

Figure 3-1

OPERATION

The following paragraphs and Figures will help you become familiar with the operation of your new Digital FM Stereo Tuner. Note that there is no volume control on the Tuner, as the audio output is held to a fixed audio level.

The sound output of your entire Tuner-Amplifier system will be determined by the level control settings of your Amplifier.

TUNING MODES

Three separate tuning modes are available on your Digital Tuner: the Keyboard Mode, the Auto-Sweep Mode, and the Preprogrammed Mode. Each one will be described separately in the following pages. And since some of the pushbuttons and controls are used in all tuning modes, their operation will only be described once.

Set the controls and switches as follows. Do not change any of their settings unless directed to do so in a step.

<u>SET</u>	<u>TO</u>
All pushbuttons	Out (released) position.
AUTO-SWEEP SPEED control	Fully counterclockwise.
NOISE SQUELCH control	Fully counterclockwise.
AGC SQUELCH control	Fully counterclockwise.
SIGNAL-MULTIPATH switch	SIGNAL.
STEREO-BLEND-MONO switch	STEREO.

KEYBOARD MODE

Refer to Figure 3-1 for the following paragraphs. The pushbuttons and controls that are shaded are used in the

Keyboard Mode of operation.

- () Press the POWER ON button to the ON (in) position. Then turn on your amplifier system and set the amplifier for a low-level sound output.
- () Select a local fm station, preferably one that broadcasts in stereo, and note its frequency (106.9 MHz for example).
- () Press the KEYBOARD button to the ON (in) position. The front panel RE-PROGRAM lamp should light and the readout should display 00.1 MHz.

NOTE: Press the RESET button to clear any undesired frequency that has been programmed into the Tuner. If in the following step you press a wrong keyboard button, simply press the RESET button and start over again. Note also, that only a single digit odd number can appear to the right of the readout decimal point. A two or three digit odd or even number can appear to the left of the readout decimal.



() Referring to the example frequency of 106.9 MHz, press corresponding keyboard buttons 1, 0, 6, and 9. The program material will be heard from your speaker system and the following front panel indications will occur:

1. The readout will display 106.9 MHz.
2. The RE-PROGRAM lamp will go out.
3. If the station is broadcasting in stereo, the STEREO lamp will light.
4. The SIGNAL meter will indicate the relative signal strength.

() Move the SIGNAL-MULTIPATH switch to the MULTIPATH position. The meter reading should decrease to zero if no multipath signal reception is taking place. If multipath reception of the station signal is occurring, the meter pointer will read upscale and jump with every music or voice tone. NOTE: Minimizing the effect of multipath reception will be discussed later in this Manual (Page 155).

() Move the switch to the SIGNAL position and note the position of the meter pointer.

NOTE: The NOISE SQUELCH control and its associated circuit are used in all tuning modes. However, this control will be effective only on signals that have high noise levels.

() Use the KEYBOARD buttons to program an fm station into the tuner that is noisier than what you consider to be acceptable. Then adjust the NOISE SQUELCH control until this station can no longer be heard. Now the Tuner will not pass any fm signal that has noise above this set level. But if you press in the SQUELCH DEFEAT button, this squelch action will be suppressed and any station can be tuned in, regardless of its noise level. Normally the NOISE SQUELCH control will be set fully clockwise.

NOTE: The following step will show the effect obtained when an improper frequency is programmed into the Tuner.

() Press the RESET button to clear the Tuner and readout; then press keyboard buttons 1, 2, 0, and 9. The readout will display the frequency 120.9 MHz. However, the RE-PROGRAM lamp will light which indicates that an incorrect frequency has been programmed into the Tuner, and nothing will be heard from your speaker system. Note that the

RE-PROGRAM lamp will light whenever the RESET button is pressed or any error is made when you program the Tuner.

AUTO-SWEEP MODE

In this mode of operation, the Tuner sweeps downward through the frequencies (107.9 MHz to 88.1 MHz) in the commercial fm band, and stops at any station above the minimum acceptable level you have set with the AGC SQUELCH control. The Tuner passes on from one station to the next one each time you press the BYPASS control. The readout will display the frequency at any given instant and also the frequency being received when the Tuner stops at an FM station. When the sweep starts downward from the high end of the fm band, the UNLOCKED lamp will gradually flash dimmer each time the frequency changes. The sweep rate is determined by the setting of the AUTO-SWEEP-SPEED control.

The readout counts downward in steps from 107.9 MHz. The numbers to the right of the decimal count down by odd numbers (9, 7, 5, etc.). The number to the left of the decimal decreases by one (107, 106, 105, etc.) each time the number to the right of the decimal counts down through a complete 9 through 1 cycle.

Refer to Figure 3-2. The pushbuttons and controls that are shaded in this Figure are used in the Auto-Sweep Mode of operation.

() Press the AUTO-SWEEP pushbutton. The readout should first display 107.9 MHz and then start to count down. The count down will continue until the readout displays the frequency of an FM station receivable in your area, at which time the Tuner will stop. No sound will be heard until lock-in occurs. NOTE: If frequency count down does not start immediately, press the RESET and then the BYPASS buttons to clear the Tuner and allow the countdown to start.

Assuming that the first station receivable in your area is at 106.9 MHz, the readout should count down to this frequency; the Tuner should lock-in; and the following events should occur.

1. The readout will display 106.9 MHz.
2. The program material will be heard from your speaker system.

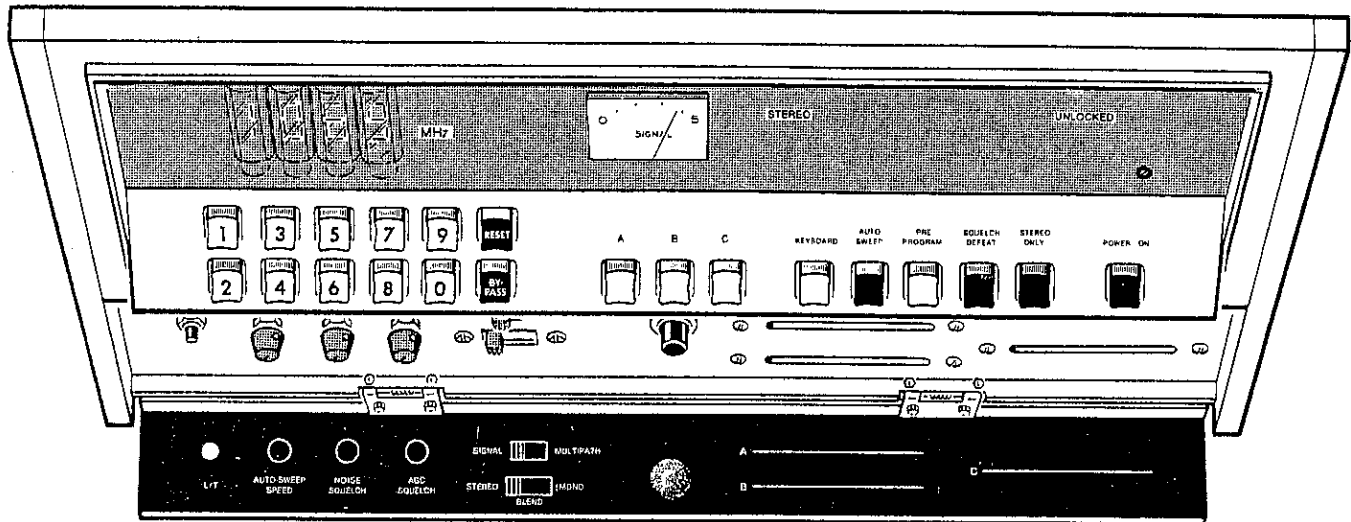

Figure 3-2

3. If the station is broadcasting in stereo, the STEREO lamp will light.
4. The SIGNAL meter will indicate the relative strength of the received signal.

NOTE: The AGC SQUELCH control and its associated circuit are used in this tuning mode. The Tuner will stop at any station with a signal greater than the minimum level determined by the setting of the AGC SQUELCH control.

- () Slowly turn the AGC SQUELCH control until you no longer hear the station that is tuned in. Now, only stations with a stronger signal than this one will cause the Tuner to stop sweeping and lock in.
- () Press the SQUELCH DEFEAT button and note that the program material will now be heard, even though the AGC SQUELCH control is set for a signal level greater than the level of the received signal. Then press and release the SQUELCH DEFEAT button.
- () Press the RESET and then the BYPASS buttons to allow the Tuner to start another downward sweep cycle. Note that this time the Tuner will not stop at the frequency tuned in the step above. It will continue to count down until it comes to a station with a signal level greater than the level set by the AGC Squelch control; then it will stop. The readout will now display the frequency of this station.
- () Again press and release the BYPASS button. The Tuner will release from this station and will count down again until it comes to another station with a

signal level great enough to overcome the AGC squelch. If the Tuner stops at a station which has noise that is above an acceptable listening level, turn the NOISE SQUELCH control until the program material can no longer be heard. The tuner will now sweep past any station that has a noise level greater than the level set by the NOISE SQUELCH control, even though the signal level is great enough to overcome the AGC squelch.

- () Press the STEREO ONLY button. Again press and release the BYPASS button. The Tuner will count down until it comes to a station broadcasting in stereo with enough received signal to overcome the AGC SQUELCH, and with a noise level below the setting of the NOISE SQUELCH control.

PREPROGRAM MODE

Preprogrammed tuning is accomplished by means of the Channel Selector cards, which you will precut to station frequencies you prefer. These precut cards are inserted through slots A, B, and C into the card sockets (card readers), which act as switches that program the tuning circuits to the proper frequencies. Pushbuttons A, B, and C allow you to choose any one of the three preprogrammed channels.

Card Programming Procedure

Read the following information and study the two examples carefully. Then prepare the Channel Selector cards, as directed, for your own use.



A Channel Selector card is programmed to a specific frequency by the way you cut out the letter-number areas from the edge of the card. There are thirteen of these letter number areas on each card. Once a card has been cut it cannot be reprogrammed to another frequency.

Refer to Figure 3-3 and note how the letter-number areas are placed at the bottom of each program card. Then study the examples below, which show how to cut a card.

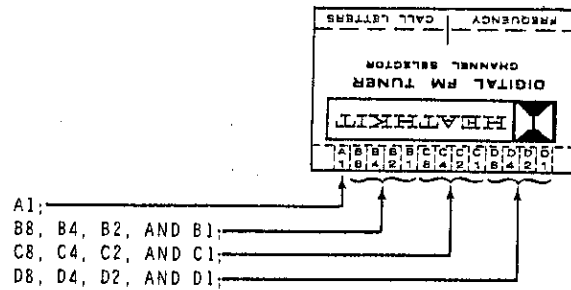

Figure 3-3

Refer to Figure 3-4 and note the frequency used for the first example, 97.3 MHz. Slots should be cut as follows in the card to represent each digit (9, 7, and 3) of this number.

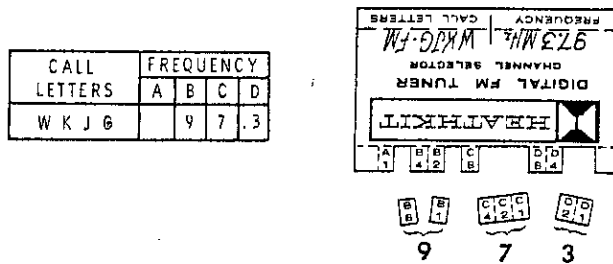

Figure 3-4

<u>UNDER LETTER</u>	<u>SLOTS CUT OUT</u>	<u>FREQUENCY</u>
A	NONE (no number in this column).	} 97.3
B	8 and 1 (B8 and B1) For a total of 9.	
C	4, 2, and 1 For a total of 7.	
D	2 and 1 For a total of 3.	

Refer to Figure 3-5 and note that a frequency of 103.5 MHz is used for the second example.

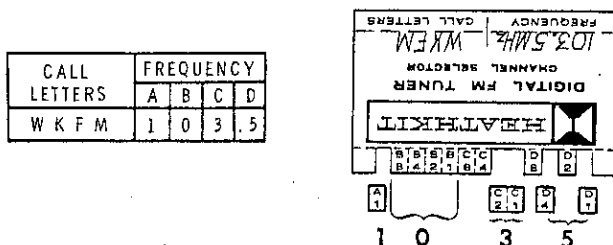

Figure 3-5

<u>UNDER LETTER</u>	<u>SLOTS CUT OUT</u>	<u>FREQUENCY</u>
A	1 (A1) For a total of 1.	103.5
B	NONE (no number in this column), 0	
C	2 and 1 For a total of 3.	
D	4 and 1 For a total of 5.	

Prepare three (or more if you prefer) Channel Selector cards in the following manner.

1. Decide which fm stations you most like to listen to.
2. Write down the call letters and frequency of each station on one of the Channel Selector cards.

3. Cut out the appropriate letter-number areas from the edge of each of these cards with a sharp pointed knife or scissors. Cut carefully along the dotted lines.

WARNING: Be careful not to cut yourself when preparing the cards.

4. Check each card out in the Tuner. (Refer to the "Preprogram Operation" steps that follow.)

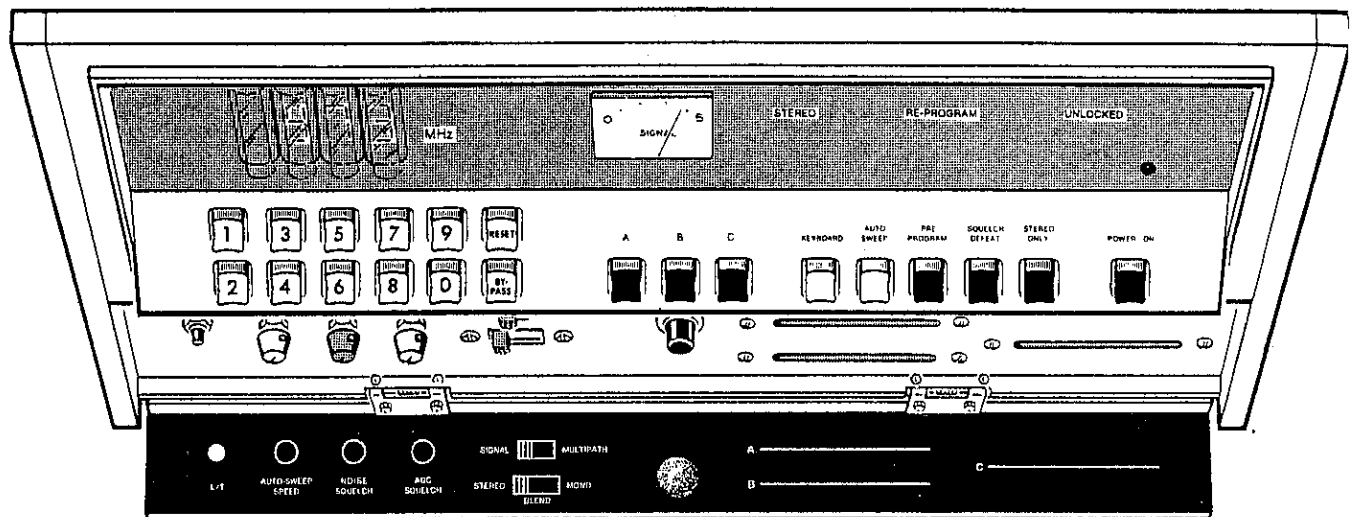

Figure 3-6

Preprogram Operation

Refer to Figure 3-6. The pushbuttons and controls that are shaded in this Figure are used when the Tuner is operated in the Preprogrammed mode.

NOTE: The following two steps describe the readout and the panel lamp indications obtained before the Channel Selector cards are installed in the Tuner.

- () Press the PREPROGRAM button. With card selector buttons A, B, and C released ("out" position), the readout should display 00.1 MHz, and the RE-PROGRAM lamp should light.
- () Press button A, B, or C. The readout should display 1-blank-blank-decimal-blank, and the RE-PROGRAM and UNLOCKED lamps should light.

- () Insert a preprogrammed Channel Selector card in slot A. Then press button A. Program material will be heard from your speaker system and the readout will display the frequency of the preprogrammed station.
- () Insert preprogrammed Channel Selector cards in slots B and C. Now pressing any one of the three card selector buttons will select the corresponding preprogrammed station. Any preprogrammed cards can be used for instant station selection. If ac power should be turned off or interrupted for any reason, while the Tuner is in the Preprogram Mode, the selected station will still be "tuned in" when ac power is restored. The NOISE SQUELCH control is effective in this tuning mode and operates the same as it does in the Keyboard Mode. The SQUELCH DEFEAT and STEREO ONLY buttons are also operational in this mode.

CONTROL FUNCTIONS

Refer to Figure 3-7 (fold-out from Page 155) for a brief description of the operation of each pushbutton and control on your Tuner. The letters in the boxes on this Figure are keyed to the letters that precede following paragraphs.

A READOUT

Displays the frequency of the programmed station.

B RESET BUTTON

Functions in the Keyboard and Auto-Sweep modes. The programmed frequency will be cleared when this

button is pressed; and the Tuner will reset to 107.9 MHz in the Auto-Sweep mode and 00.1 in the Keyboard mode.

C BYPASS BUTTON

Only functions in the Auto-Sweep mode. Pressing this button will override the locked-in station and allow the Tuner to sweep down to another station.

D METER

Indicates relative signal strength, or multipath interference of a station's signal.

- | | |
|--|---|
| <p>E STEREO LAMP</p> <p>Lights only when the station being received is broadcasting in stereo.</p> | <p>M AC POWER</p> <p>Turns the Tuner on and off.</p> |
| <p>F RE-PROGRAM LAMP</p> <p>Lights when an improper frequency is programmed into the Tuner.</p> | <p>N PREPROGRAMMED CARDS</p> <p>Any three preprogrammed Channel Selector cards may be used. Used in conjunction with PREPROGRAM button.</p> |
| <p>G UNLOCKED LAMP</p> <p>May momentarily flash each time the Tuner sweeps downward while it is operating in the Auto-Sweep mode. Will light when the Tuner is in a completely unlocked state.</p> | <p>O CARD SELECTION BUTTONS</p> <p>Used to select one of the three stations preprogrammed on the Channel Selector cards.</p> |
| <p>H KEYBOARD BUTTON</p> <p>When this button is pressed in, the readout will be cleared. Tuning is then accomplished by use of the Reset button and buttons 1 through 0 on the keyboard.</p> | <p>P DOOR LOCK RELEASE</p> <p>When the access door is closed, light pressure on it will trip the lock and allow the door to open.</p> |
| <p>I AUTO-SWEEP BUTTON</p> <p>Will cause the Tuner to sweep the entire commercial fm band. The tuner will automatically stop at stations.</p> | <p>Q STEREO-BLEND-MONO SWITCH</p> <p>Allows you to select one of three types of reproduction: normal stereo reproduction, blending of both channels, or both channels combined for monaural output. The BLEND position blends both channels to reduce high frequency noise from fm stereo signals. However, the stereo separation may also be reduced.</p> |
| <p>J PREPROGRAM BUTTON</p> <p>Will put the Tuner in the Preprogram mode which utilizes the three preprogrammed channel selector cards.</p> | <p>R SIGNAL STRENGTH/MULTIPATH SWITCH</p> <p>Operates in conjunction with the Signal meter to show the relative strength of received signals or to indicate multipath interference of station signal. NOTE: See Page 155 for information about multipath reception.</p> |
| <p>K SQUELCH DEFEAT BUTTON</p> <p>When this button is pressed in, all audio squelch action is defeated. This allows you to listen to all stations that can be received, regardless of the noise level or signal strength of the station. The SQUELCH DEFEAT button is ineffective if the RE-PROGRAM light is on.</p> | <p>S AGC SQUELCH CONTROL</p> <p>Only effective in the Sweep mode. The setting of this control determines the minimum amount of signal required to stop the Tuner at a station.</p> |
| <p>L STEREO ONLY BUTTON</p> <p>The STEREO ONLY button is effective in all three tuning modes. When this button is pressed, the only program material you hear will be from stations broadcasting in stereo. When this button is in its released (out) position, you can hear both stereo and monaural program material.</p> | <p>T NOISE SQUELCH CONTROL</p> <p>Effective in all three modes. Its setting determines the maximum level of noise acceptable.</p> |
| | <p>U SWEEP SPEED CONTROL</p> <p>Only effective in the Auto-Sweep mode. Turn this control counterclockwise to decrease the sweep speed and clockwise to increase the sweep speed.</p> |



V LIGHT TEST SWITCH

Tests the readout display tubes. When pressed, it will override the readout and display 188.8 MHz, with no effect on the programmed station.

W KEYBOARD BUTTONS (1 through 0)

Only effective in the Keyboard mode. Use to program the frequency of the desired fm station into the Tuner.

MULTIPATH SIGNALS

Broadcast signals originate as one signal from the fm transmitting station. Part of these signals are transmitted directly to your receiver antenna, while other parts of the signal are reflected off mountains, water towers, buildings, etc., and then received by your antenna. The reflected signal arrives at your antenna slightly later than the direct signal. See Figure 4-1. The reflected signal is a multipath signal.

This reflected signal can degrade the quality of tuner performance in several ways:

1. Stereo reception may be reduced or entirely lost.
2. Distortion may be heard in the program signal.
3. Often there is an increase in background noise.
4. Stereo indicators may not indicate a stereo station, or may behave erratically.

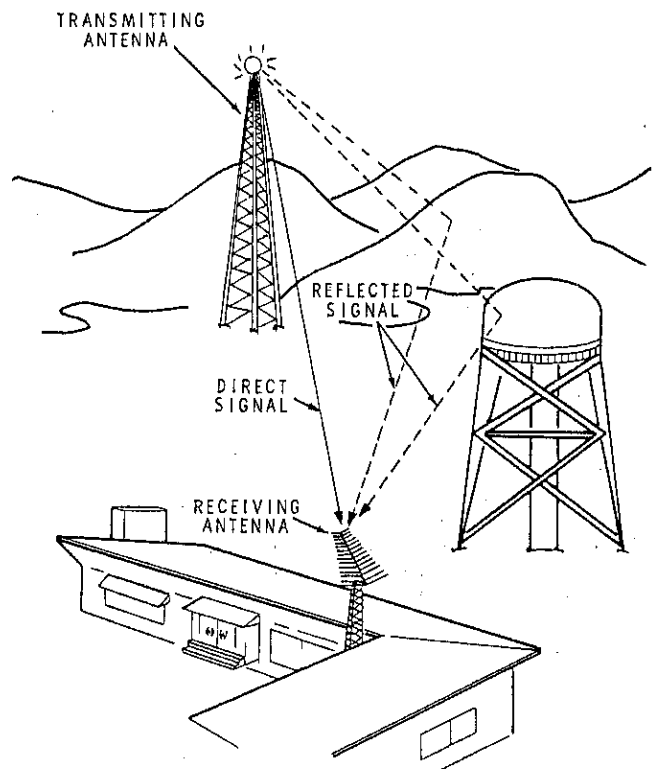

Figure 4-1

MINIMIZING MULTIPATH RECEPTION

A good commercial fm antenna is required for optimum reception, except for strong stations near the Tuner. Antennas may be of two types, those designed only for fm reception, and those that are combined with vhf/uhf television antennas. Selection of the most desirable type of antenna will depend on your personal requirements. You probably will want to purchase a separate fm receiving antenna if you will be using your television and fm Tuner at the same time.

Multipath interference can usually be minimized by turning your antenna until only the direct signal is received. Strong, clear reception indicates that your antenna is receiving the direct signal with little or no multipath interference. Commercial antennas are highly directional, and even a small amount of rotation away from the direct signal can create multipath problems.

If considerable distortion and noise are present when you are tuned to a station, and the SIGNAL meter indicates a good signal strength, perform the following steps.

1. Refer to Figure 4-2 and place the SIGNAL-MULTIPATH switch in the MULTIPATH position and observe the SIGNAL meter.
2. Slowly rotate the fm antenna, first in one direction and then in the other. Multipath signals will cause the SIGNAL meter to fluctuate up-scale with each music or voice tone.
3. Rotate the antenna until the least amount of fluctuation and the lowest indication is observed on the meter. This is the optimum antenna direction.
4. Place the SIGNAL-MULTIPATH switch in the SIGNAL position.

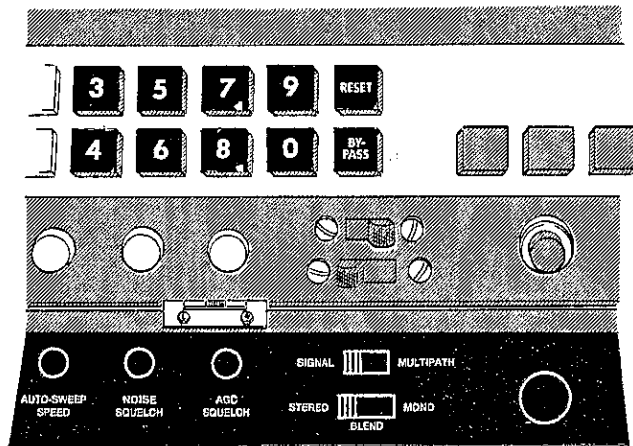
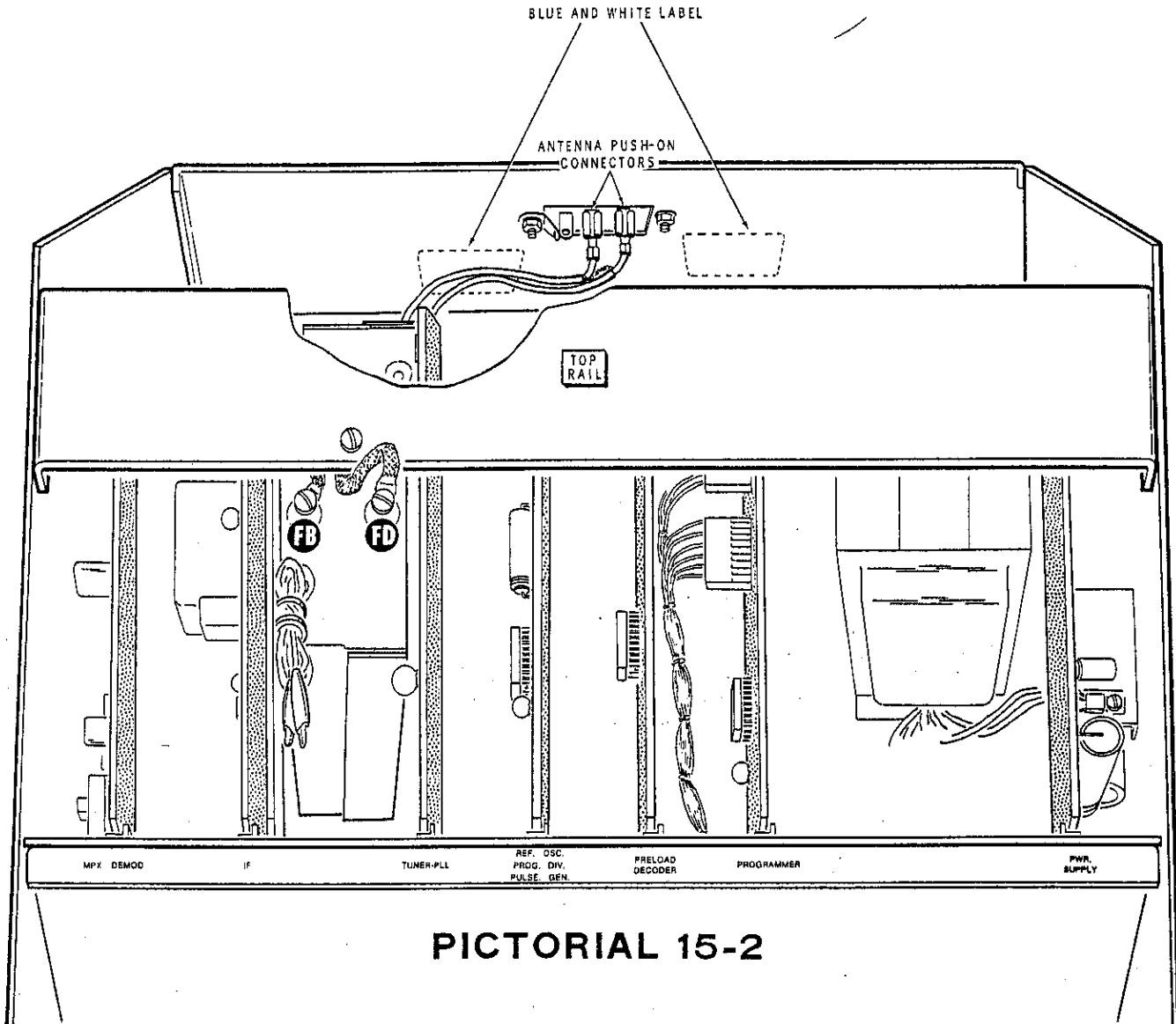

Figure 4-2

OSCILLOSCOPE TUNING INDICATORS

Oscilloscope tuning indicators, which can be connected to the SCOPE INPUTS at the rear of the Tuner, are also effective in minimizing the multipath effect. Several firms have marketed oscilloscope tuning indicators. However, you can also use any oscilloscope that has dc amplifiers for both horizontal and vertical inputs. If you have a commercial tuning indicator, refer to its operation manual for instructions on how to use it. If you intend to use a dc oscilloscope, the following steps will show you how it can be used.



PICTORIAL 15-2

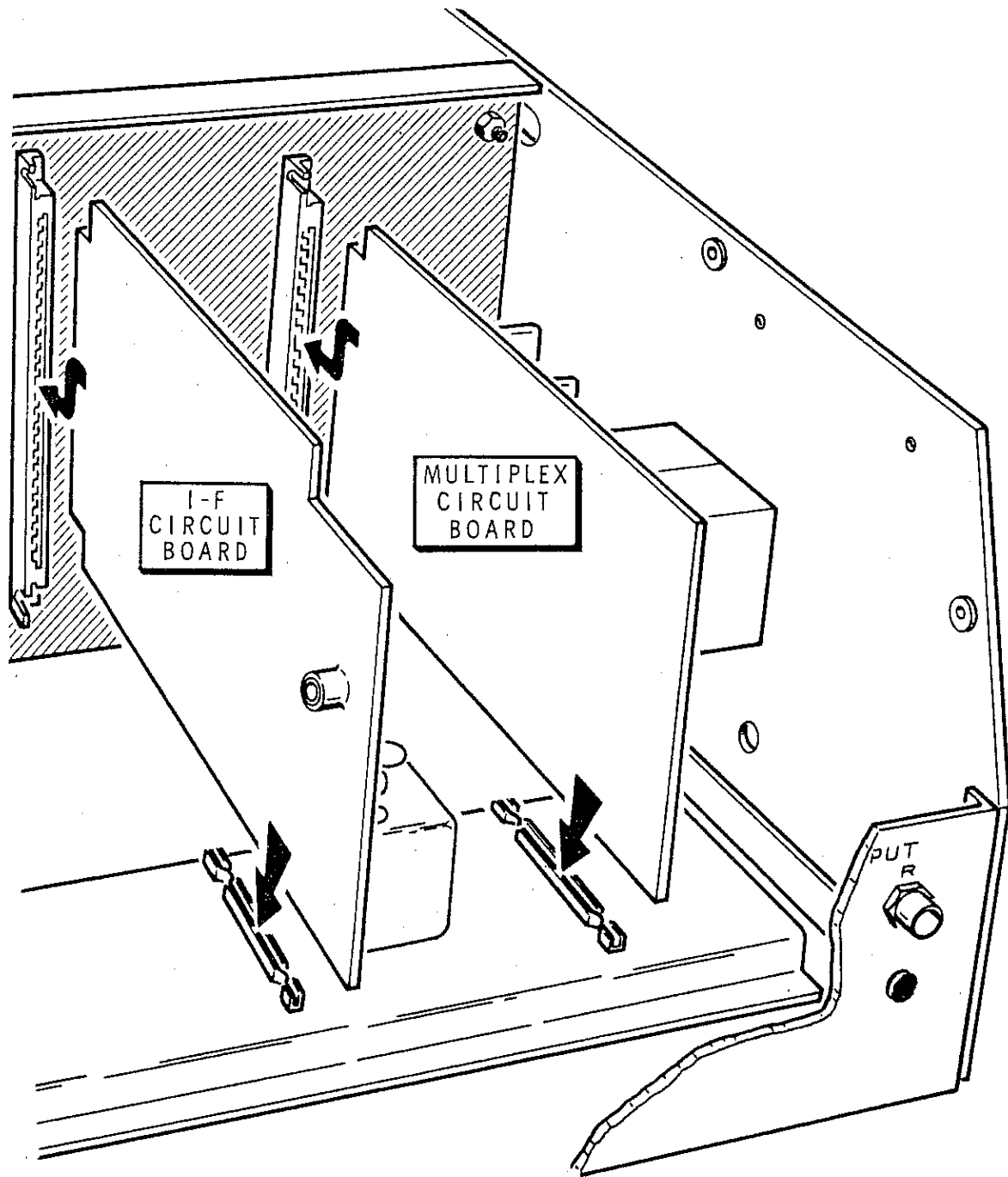

Figure 1-11

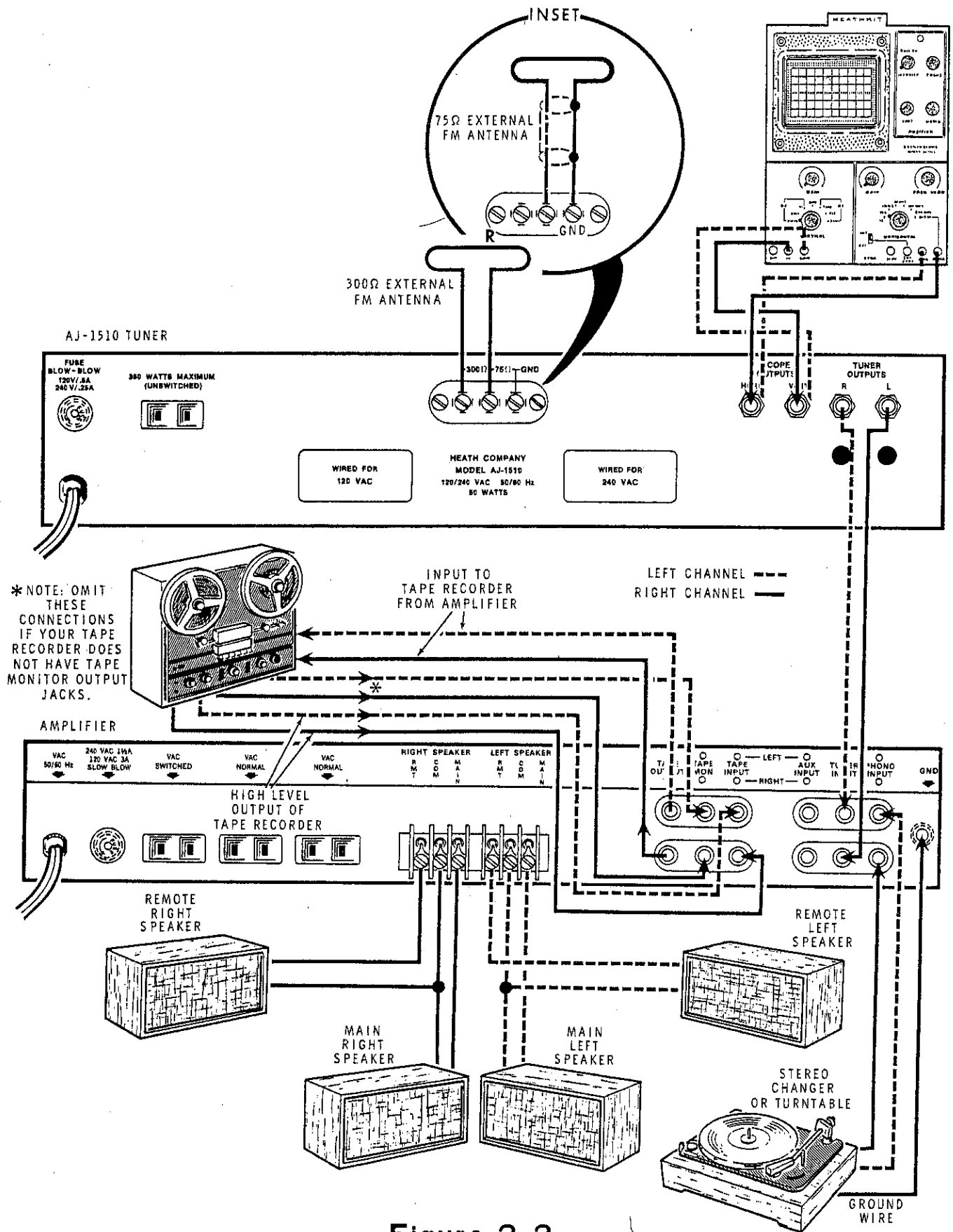

Figure 2-2

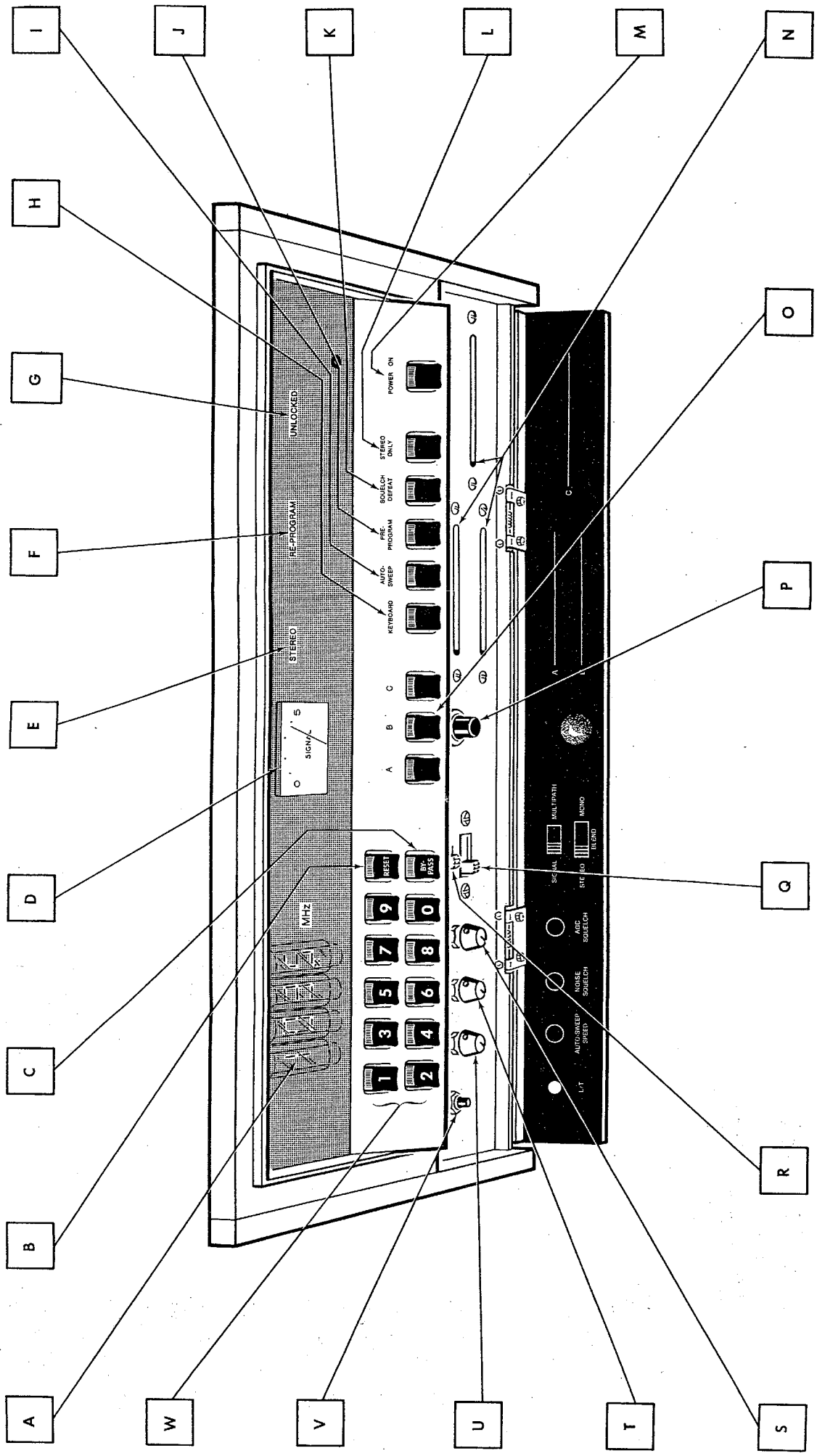

Figure 3-7

The following four oscilloscope photographs were taken under multipath interference conditions.



Figure 4-4

Perfectly tuned monophonic signal with 100% modulation.

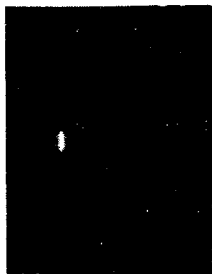

Figure 4-5

Station transmitting 19 kHz pilot only.

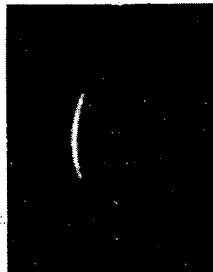

Figure 4-6

Station transmitting stereo at near 100% modulation: near perfect signal.



Figure 4-7



Figure 4-8



Figure 4-9

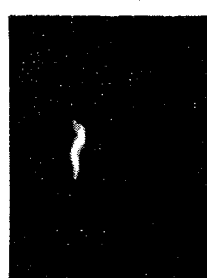

Figure 4-10

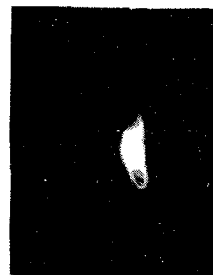

Figure 4-11

Signal that shows very rapid fluctuations in signal strength.

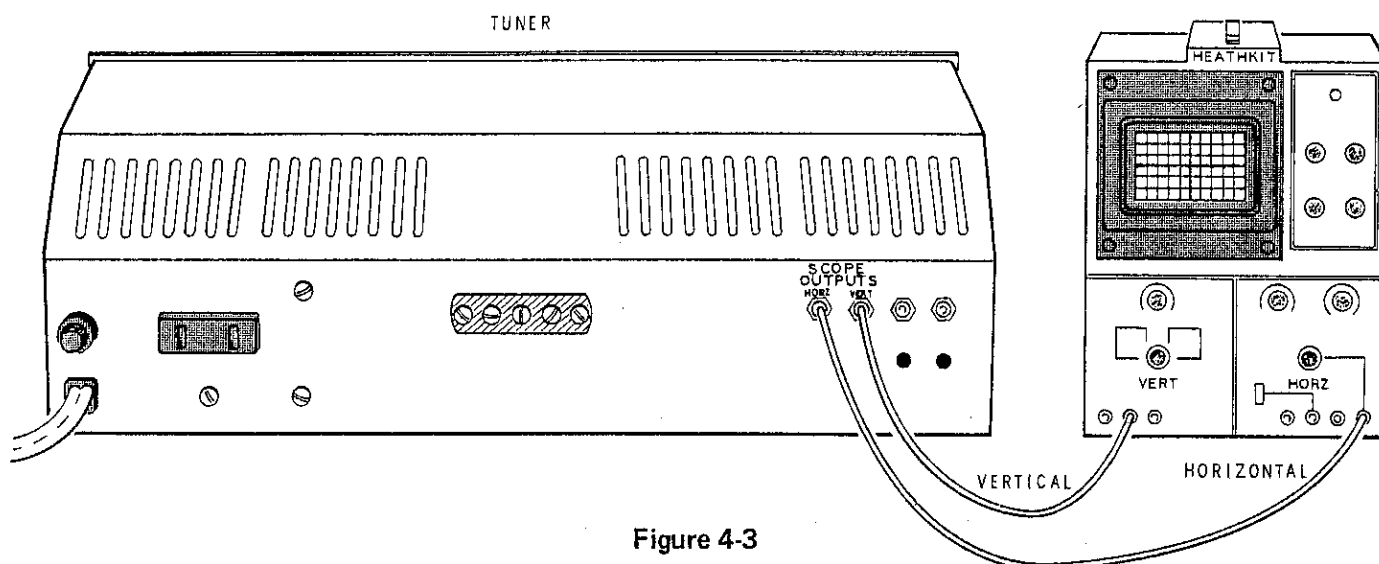

Figure 4-3

Refer to Figure 4-3.

1. Connect the horizontal input of the oscilloscope (or tuning indicator) to the SCOPE OUTPUTS HORIZ phono socket on the Tuner rear panel.
2. Connect the vertical input of the oscilloscope to the SCOPE OUTPUTS VERT phono socket on the Tuner rear panel.
3. Adjust the horizontal gain on the oscilloscope to obtain the desired horizontal display. Adjust the vertical gain so the display is near the bottom of the

screen on weak stations and near the top of the screen on strong-stations.

Now the amplitude of the display along the vertical centerline will indicate the relative strength of the signal, and the width of the display will indicate the relative modulation percentage of the signal. Horizontal centering of the display on the oscilloscope screen will indicate the centering of the received signal.

Figures 4-4 through 4-11 (fold-out from Page 156) are photographs of typical oscilloscope displays. With each photograph is an analysis of the conditions under which each scope display was received.



IN CASE OF DIFFICULTY

CONTENTS

<u>TITLE</u>	<u>Page</u>
Visual Checks	160
Troubleshooting Chart	160
Bench Testing	164
Checking Components	165
Test Charts	169
Alignment with Instruments	188
Factory Repair Service	191
Replacement Parts and Price Information	192

This part of the Manual is divided into the six sections listed above. Each section has a different type of information. Use these sections to resolve your difficulty in the following manner.

Do the "Visual Checks" first, and do them carefully, even if you are an experienced kit builder. Most of the kits (about 90%) that are returned to the Heath Company for repair do not work properly because of poor solder connections, wiring errors, or misplaced parts. It is very easy to consistently overlook a wiring error or poor connection.

After you complete the "Visual Checks," proceed to the "Troubleshooting Chart" and see if your difficulty is listed

there. Several possible causes are listed for each difficulty, or you may be directed to one or more of the "Test Charts" to narrow your problem down to a specific area or part. Use the "Checking Components" section to test any capacitor, diode, or transistor that you think may be faulty.

NOTE: Be sure to read the "Precautions" section (Page 164) of "Bench Testing" before performing any tests on the Tuner. Also read the "Extender Circuit Board" information (Page 164).

If you have some knowledge of electronics, a great deal of additional information is also available to you. If you narrow down the difficulty to a particular circuit, you may be able to go directly to one of the "Test Charts." Also refer to the:

- Schematic (fold-out from Page 227)
- Block Diagram (fold-out from Page 194)
- Circuit Description (Page 195)
- Circuit Board X-Ray Views (Page 215)
- Chassis Photographs (Page 224)

Be sure, when repairing your Tuner, to eliminate the cause as well as the effect of the trouble. If, for example, you should find a damaged resistor, be sure you find out what it was (wiring error, etc.) that caused the resistor to become damaged. If the cause is not eliminated, the replacement resistor may also be damaged when the Tuner is put back into operation.

The "Factory Repair Service" section is provided in case you prefer to have your Tuner, either the complete kit or just one of the circuit board modules, serviced at the factory — or at a Heathkit Electronic Center.

VISUAL CHECKS

NOTE: The following checks will be most effective if you apply them to one circuit board module, or other part of the kit, at a time.

1. About 90% of the kits that are returned for repair do not function properly due to poor connections and soldering. Therefore, many troubles can be eliminated by a careful inspection of connections to make sure they are soldered as described in the "Soldering" section of the "Kit Builders Guide." Reheat any doubtful connections and be sure all the wires are soldered at places where several wires are connected.
2. Check each circuit board to be sure there are no solder bridges between adjacent connections. Remove any solder bridges by holding a clean soldering iron tip between the two points that are bridged until the excess solder flows down the tip of the soldering iron.
3. Be sure each transistor and each integrated circuit is in the proper location (correct part number and type number). Be sure that each transistor lead is positioned properly and has a good solder connection to the foil. Check integrated circuits for proper positioning and good contact at all pin connections.
4. Check capacitor values carefully. Be sure the proper part is wired into the circuit at each capacitor location. For example, it would be easy to mistake a .001 μ F capacitor for a 100 pF capacitor. Always check the polarity of electrolytic capacitors to be sure they are installed correctly.
5. Check each resistor carefully. It would be easy, for example, to install a 2200 Ω (red-red-red) resistor where a 220 Ω (red-red-brown) resistor is called for. A resistor that is discolored, or cracked, or shows any sign of bulging would indicate that it is faulty and should be replaced.
6. Be sure the correct diode is installed at each diode location, and that the banded end is positioned correctly.
7. Recheck the wiring. Trace each lead in colored pencil on the Pictorial as it is checked. It is frequently helpful to have a friend check your work. Someone who is not familiar with the unit may notice something you have consistently overlooked.
8. Check all component leads connected to the circuit boards. Make sure the leads do not extend through the circuit board and make contact with other connections or parts, such as coil shields or the chassis.
9. Check all the wires that are connected to the circuit board plugs. Make sure the wires do not touch the chassis or other lugs. Make sure all wires are properly soldered.
10. Be sure that each of the IC pins is properly installed in its connector, and not bent out or under the IC. Also be sure the IC's are installed in their correct positions and that they are oriented properly.

Troubleshooting Chart

NOTE: When you narrow your problem to a specific area or suspected component as called out in the following chart, closely inspect the area as outlined in the "Visual Checks" before removing the component for test. Your problem could be caused by something near the component, like an open or shorted circuit board foil or a wrong connection, instead of being caused by the part itself.

SYMPTOM	POSSIBLE CAUSE
Tuner completely dead.	<ol style="list-style-type: none"> 1. Blown fuse. 2. Open line cord. 3. Faulty Power On switch. 4. Power supply circuit. Proceed to Test Chart 1.
Reception weak or noisy.	<ol style="list-style-type: none"> 1. Poor or shorted antenna connections. 2. Inadequate antenna. 3. Faulty cable and/or cable connections. 4. The i-f circuit board module. 5. The tuner-PLL circuit board module.
No Signal meter indications with good reception.	<ol style="list-style-type: none"> 1. Meter switch in Test position. 2. Signal-Multipath switch in Multipath position. 3. D608 and/or D607. 4. Q603.
No audio output.	<ol style="list-style-type: none"> 1. Audio output cables improperly installed. 2. IC601 through IC605. 3. F601 and/or F602. 4. ZD601. 5. PLL-multiplex-demodulator circuit board. 6. Squelch control circuitry.
No multipath indication.	<ol style="list-style-type: none"> 1. No multipath signal(s) being received. 2. Signal-Multipath switch in Signal position. 3. Q602 or Q603. 4. D607 and/or D608.
No AGC (automatic gain control).	<ol style="list-style-type: none"> 1. D603 and/or D604.
No audio output from left channel.	<ol style="list-style-type: none"> 1. Proceed to Test Chart 3.
No audio output from right channel.	<ol style="list-style-type: none"> 1. Proceed to Test Chart 4.
No audio except when the Squelch Defeat button is in.	<ol style="list-style-type: none"> 1. Proceed to Test Chart 5.

SYMPTOM	POSSIBLE CAUSE
No Scope Horiz output (on rear panel).	<ol style="list-style-type: none"> 1. IC607. 2. IC608. 3. Q602. 4. D601 and/or D602.
No Stereo light.	<ol style="list-style-type: none"> 1. Station not broadcasting in stereo. 2. IC701. 3. R706 not properly adjusted. 4. Q718, Q4, and/or Q5.
No separation between left and right channels when tuned to a known stereo station.	<ol style="list-style-type: none"> 1. Stereo-Blend-Mono switch in Mono position. 2. Short between left and right channel foils on multiplex circuit board module. 3. R706 not properly adjusted. 4. IC701.
No downward sweep in Auto-Sweep mode.	<ol style="list-style-type: none"> 1. Proceed to Test Chart 6. 2. Proceed to Test Chart 2.
Tuner stops on noisy signals in the Auto-Sweep mode.	<ol style="list-style-type: none"> 1. L602 on the i-f circuit board is improperly adjusted. 2. Noise Squelch control improperly adjusted.
No audio output, with frequency readout displayed and signal meter showing signal strength.	<ol style="list-style-type: none"> 1. Amplifier and/or speaker connections. 2. Proceed to Test Chart 5.
Unable to program in all modes.	<ol style="list-style-type: none"> 1. Proceed to Test Chart 2.
Inaccurate programming in Preprogram mode only.	<ol style="list-style-type: none"> 1. Channel Selector card inaccurate or bent. 2. Card socket damaged or wired incorrectly. 3. IC5 through IC8.
Re-Program light remains on at all times or will not light.	<ol style="list-style-type: none"> 1. Q901. 2. IC9. 3. Preload decoder circuit board.

SYMPTOM	POSSIBLE CAUSE
Stereo light remains on at all times or will not light.	<ol style="list-style-type: none"> 1. Q4 and/or Q5.
Keyboard does not program correctly. Auto-sweep is ok.	<ol style="list-style-type: none"> 1. Proceed to Test Chart 2. 2. Proceed to Test Chart 11.
Frequency readout will not clear to 00.1 MHz.	<ol style="list-style-type: none"> 1. Check display tubes with L/T (light test) button. 2. Proceed to Test Chart 2. 3. Proceed to Test Chart 11. 4. IC1 through IC4.
Unlocked light remains on when Tuner is programmed for a correct frequency or will not light at all.	<ol style="list-style-type: none"> 1. Check Unlocked light socket and wiring for possible short. 2. Proceed to Test Chart 7. 3. Proceed to Test Chart 8. 4. Proceed to Test Chart 9. 5. Proceed to Test Chart 10. 6. Proceed to Test Chart 12.
Incorrect station and/or no station is received when programmed for a correct frequency.	<ol style="list-style-type: none"> 1. Proceed to Test Chart 12.
Signal meter will not go to zero when i-f cable is disconnected.	<ol style="list-style-type: none"> 1. Q604. 2. D605 and/or D606 faulty or reversed.

BENCH TESTING

PRECAUTIONS

1. Be cautious when testing transistor circuits. Although transistors have almost unlimited life when used properly, they are much more vulnerable to damage from excessive voltage or current than vacuum tubes. A vacuum tube can often be operated under shorted, zero-bias, excessive-voltage, or high-current conditions for short periods of time without materially damaging the tube. Any one of these same conditions can completely destroy a transistor instantly.
2. Be sure you do not short any terminals to ground when making voltage measurements. If the probe should slip, for example, and short out a bias or voltage supply point, it is almost certain to cause damage to one or more transistors or diodes.
3. Do not remove transistors or integrated circuits while the Tuner is turned on. This could damage the parts removed and/or other parts in the circuit.
4. Do not remove or install circuit boards while the Tuner is turned on.

CAUTION: The full AC line voltage is present inside the AC shield and around the Power On switch. Be sure to keep away from these areas when you perform power on checks.

EXTENDER CIRCUIT BOARD

Use the Extender circuit board supplied with this kit to extend circuit board modules out of the chassis for easy access during alignment and/or troubleshooting.

CAUTION: Always press the Power On button to the off (out) position before removing or reinstalling a circuit board module. Once the circuit board module has been removed or installed, the Power On button can be pressed to the On position without damage to the circuits.

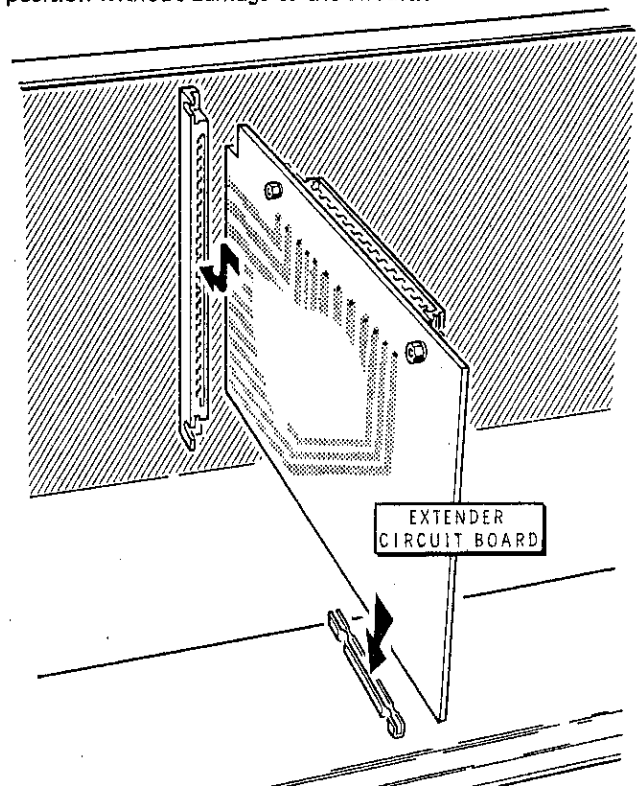

Figure 5-1

Extender Circuit Board Installation

Refer to Figure 5-1 for the following steps.

1. Remove the wooden cabinet from the Tuner, or remove the Tuner from its custom installation if one is used.
2. Remove the top shield from the Tuner.
3. Remove the top rail from the Tuner.
4. Carefully remove the desired circuit board module from the Tuner.
5. Connect the extender circuit board module to the circuit board module removed from the Tuner.
6. Install this circuit board combination into the Tuner.

Special Considerations

Although the Power Supply circuit board module cannot be extended from the Tuner chassis, space has been provided for you to make measurements on its foil side. Refer to the "X-Ray Views" on Page 215 to locate the foils connected with the component you want to check.

Disconnect the antenna cables, coaxial cable, and ground strap from the Tuner/phase-lock-loop (Tuner-PLL) circuit board before extending it. Temporarily connect your fm antenna directly to the antenna cables. Use the extender cable (previously prepared) between the coaxial cable on the circuit board module and the phono socket on the i-f circuit board module. Also use the extender cable between these same two points when extending the i-f circuit board module.

CHECKING COMPONENTS

The Signal meter can be used to check transistors, diodes, and capacitors. Be sure, before you check a part, that you have applied the "Visual Checks" (Page 160) to that part and the area around it. Remember that a shorted (solder bridged) foil or an open connection can often give the same indication as a bad part.

IMPORTANT: Be sure to place the Meter switch (located on the master circuit board) in the Test position and the Range switch in the Ohms position before testing components.

HOW TO CHECK TRANSISTORS

- A. Unsolder and remove the transistor from its circuit.

- B. Refer to Figure 5-2 and connect the leads of the transistor as directed in the "Transistor Checkout Chart" on Page 166 for the type of transistor you want to check.
- C. If the meter reading indicates that a transistor is faulty, recheck the reading before you obtain a replacement part.

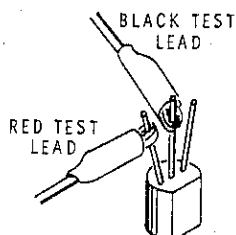

Figure 5-2

CONNECT THE BLACK TEST LEAD TO ONE LEAD OF THE TRANSISTOR AS DIRECTED IN COLUMN 3 OF THE CHART.

CONNECT THE RED TEST LEAD TO ANOTHER LEAD OF THE TRANSISTOR AS DIRECTED IN COLUMN 2 OF THE CHART.

TRANSISTOR CHECKOUT CHART

TRANSISTORS	Connect the RED TEST LEAD TO TRANSISTOR LEAD:	Connect the BLACK TEST LEAD TO TRANSISTOR LEAD:	SIGNAL METER READING	
<p>S2090 (417-110)</p> <p>WIDE SPACE BETWEEN E AND C</p>	B	C	LOW	
	B	E	LOW	
	E	C	LOW	
	E	B	HIGH	
	C	B	HIGH	
<p>2N3393 (417-118) TZ1160 (417-218)</p> <p>FLAT</p>	B	C	LOW	
	B	E	LOW	
	E	C	LOW	
	E	B	HIGH	
	C	B	HIGH	
<p>X29A829 (417-201)</p>	B	C	HIGH	
	B	E	HIGH	
	E	C	LOW	
	E	B	LOW	
	C	B	LOW	
<p>2N5294 (417-175)</p>	B	C	LOW	
	B	E	LOW	
	E	C	LOW	
	E	B	HIGH	
	C	B	HIGH	

HOW TO CHECK DIODES

- Unsolder and remove the diode from its circuit.
- Refer to Figure 5-3 and connect the leads of the diode as directed in the "Diode Checkout Chart."
- If the meter reading indicates that a diode is faulty, recheck the reading before you obtain a replacement part.

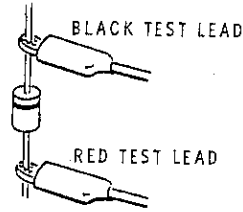

CONNECT THE BLACK TEST LEAD TO ONE LEAD OF THE DIODE AS DIRECTED IN COLUMN 2 OF THE CHART.

CONNECT THE RED TEST LEAD TO THE OTHER LEAD OF THE DIODE AS DIRECTED IN COLUMN 3 OF THE CHART.

Figure 5-3

DIODE CHECKOUT CHART

DIODES	Connect the RED TEST LEAD TO DIODE LEAD:	Connect the BLACK TEST LEAD TO DIODE LEAD	SIGNAL METER READING
56-26 56-35 56-47 56-59 56-74 57-27 57-42 	C	A	HIGH
	A	C	LOW

HOW TO CHECK CAPACITORS

These instructions are divided into two groups. The first group is for capacitors of 50 μF and above. The second group is for capacitors below the value of 50 μF . After reading steps A, B, and C, proceed to the group of instructions for the part you intend to check.

- Unsolder and remove the capacitor.
- Discharge the capacitor by touching the leads together. (Note the special discharging instructions below for the 6000 μF capacitor.)

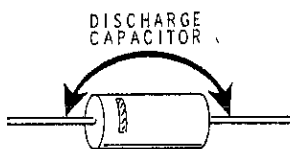

- Connect the black test lead to one lead of the capacitor. Then, while watching the Signal meter, touch the red test lead to the other capacitor lead. (Note the special instructions for the electrolytic capacitors.)

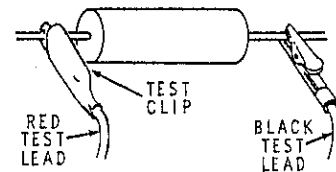

How to Discharge the 6000 μF Capacitor

The 6000 μF capacitor retains a very high charge and should be handled very carefully. **Never touch the lugs of this capacitor until you are absolutely sure that it is discharged.** Use either of the following two methods to make sure that the capacitor is discharged.

METHOD A: Leave the Tuner turned off for approximately five minutes. This will allow the capacitor to discharge through the Tuner circuitry. Then short the two lugs of the capacitor together momentarily with the blade of a screwdriver. Now it is safe to disconnect the wires and remove the capacitor for test.

METHOD B: Turn the Tuner off and short the two lugs of the capacitor together with a 100 Ω , 2-watt resistor. Hold the resistor body in your fingers. Do not touch the resistor leads. Place the resistor between the lugs of the capacitor for several seconds; then remove it. Now short the two lugs together momentarily with the blade of a screwdriver. It is now safe to disconnect the wires and remove the capacitor for test.

Electrolytic Capacitors

Each electrolytic capacitor has a positive (+) mark at one end of its case. When checking one of these capacitors, always connect the positive (+) end of the capacitor to the black test lead. Then connect the other capacitor lead to the red test lead.

Checking Capacitors

Use the procedure in steps 1, 2, 3, and 4 for checking capacitors of 50 μF and above. Steps 5, 6, and 7 are for capacitors below the value of 50 μF . Read through all the steps before proceeding with a check.

1. If the meter pointer deflects to the right side quickly, and then gradually returns to the left side, the capacitor is not faulty. NOTE: The time it takes for the pointer to return to the left side of the meter scale depends upon the value of the capacitor being checked. A 50 μF capacitor, for example, will cause the pointer to return more rapidly than a 500 μF capacitor.
2. If the meter pointer deflects to the right side and stays there, the capacitor is faulty (shorted).
3. If the meter pointer does not deflect at all, but stays at the left side, the capacitor is faulty (open).
4. Recheck the capacitor, BUT FIRST DISCHARGE IT BY TOUCHING THE TWO CAPACITOR LEADS TOGETHER.

CAPACITOR OK



CAPACITOR FAULTY (SHORTED)



CAPACITOR FAULTY (OPEN)

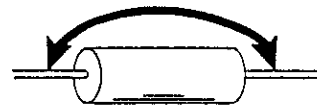

The next three steps are for checking capacitors below the value of 50 μF . Because of the small capacitance of these capacitors, it takes only a split second for them to charge. Therefore, it is difficult to determine if the capacitor is faulty (open). Recheck the capacitor several times while watching the meter closely. Be sure to discharge the capacitor each time before repeating your check.

5. If the meter pointer deflects slightly and then remains at the left side of the meter scale, the capacitor is not faulty.

CAPACITOR OK

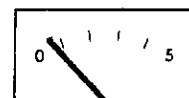

6. If the meter pointer does not deflect at all, but remains at the left side of the meter scale, the capacitor is faulty (open). NOTE: Very small value capacitors (3.3 to 33 pF), because of their small capacity to hold a charge, may not cause the meter to deflect. This is normal for these small capacitors.
7. If the meter pointer deflects to the right side and stays there, the capacitor is faulty (shorted).

NOTE: Before you replace the cabinet on your Tuner, be sure to place the Meter switch in the NORM position and to store away the test leads in the plastic clamp.

TEST CHART INDEX

TEST CHARTS

1	Power Supply Circuit	170
2	Programmer and Data Multiplex Circuits	172
3	Left Channel Multiplex Circuit	176
4	Right Channel Multiplex Circuit	177
5	Multiplex Circuit	178
6	Auto-Sweep Pulse Generator Circuit	179
7	Phase Detector and Loop Filter Circuit	180
8	100 kHz Crystal Oscillator and Divide-by-4 Reference Scaler Circuit	181
9	Programmable Divider Circuit	182
10	FM Tuner and VCO Frequency Scaler Circuit	182
11	Keyboard Circuit	183
12	Preload Decoder Circuit	186

NOTE: Although IC's may be listed occasionally in these charts as a "Possible Cause of Trouble," it would be quite unusual to have one that is actually faulty. Check the circuit board foils, IC connections, and area around an IC very carefully before deciding that an IC should be replaced.

TEST CHART 1

POWER SUPPLY CIRCUIT

NOTE 1: The power supply circuit board module cannot be extended from the Tuner chassis. See "Special Considerations" on Page 165.

NOTE 2: The Power Supply circuit board module is a "protected circuit." In effect, this means that one or more of the source voltages can sustain a direct short to ground for an extended period of time without damage. Any such short would, however, result in zero voltage from the circuit shorted.

- () Set the METER switch in the TEST position.
- () Set the RANGE switch in the OHMS position.
- () Remove all seven of the circuit board modules from the Tuner.
- () Press the POWER ON button to the ON (in) position.
- () Perform the tests called for on Pages 124 through 126.

STEP	INDICATION	POSSIBLE CAUSE OF TROUBLE
A	Meter reads greater than 2.5.	<ol style="list-style-type: none"> 1. Shorted insulator at Q101. 2. Solder bridge to ground from collector of Q101. 3. Q101 is defective.
	Meter reads less than 1.	<ol style="list-style-type: none"> 1. Heat sink mounting screw not grounded to circuit board. 2. Collector circuit of Q101 is open.
B	Meter reads greater than 0.	<ol style="list-style-type: none"> 1. Shorted insulator at Q104.
C	Meter reads greater than 0.	<ol style="list-style-type: none"> 1. Shorted insulator at Q109 and/or Q108.
D	Meter reads greater than 0.	<ol style="list-style-type: none"> 1. Solder bridge from +8V foil to ground. 2. Q108 and/or Q109 defective.
E	Meter reads greater than 4.	<ol style="list-style-type: none"> 1. C113 shorted. 2. +5V foil grounded. 3. Solder bridge between foils associated with transistor Q112. 4. Q112 defective.
	Meter reads less than 3.	<ol style="list-style-type: none"> 1. Open circuit associated with R124.
F	Meter reads greater than 3.5.	<ol style="list-style-type: none"> 1. Solder bridge to ground from +15V foil. 2. C111 shorted. 3. Q104 and/or Q107 defective.
	Meter reads less than 2.5.	<ol style="list-style-type: none"> 1. R117 open.
G	Meter reads greater than 0.	<ol style="list-style-type: none"> 1. D106 is defective.

STEP	INDICATION	POSSIBLE CAUSE
H	Meter reads greater than 0.	<ol style="list-style-type: none"> 1. Q104 and/or Q113 is defective. 2. C107 is shorted.
I	Meter reads greater than 4.5.	<ol style="list-style-type: none"> 1. Solder bridge to ground from +30V foil. 2. Q103 is defective. 3. C105 is shorted.
	Meter reads less than 3.5.	<ol style="list-style-type: none"> 1. Open circuit to +30V foil.
J	Meter reads greater than 0.	<ol style="list-style-type: none"> 1. D101 and/or D102 are defective.
K	Meter reads greater than 0.	<ol style="list-style-type: none"> 1. D101 and/or D102 are defective.
L	Meter reads greater than 3.5.	<ol style="list-style-type: none"> 1. Q101 or its associated foil is shorted. 2. Q102 or its associated foil is shorted. 3. Q103 is defective. 4. ZD101 is defective.
	Meter reads less than 2.5.	<ol style="list-style-type: none"> 1. Check the voltage at the positive (+) end of C102 for a meter reading of 4. If meter reads less than 4, check the following: <ol style="list-style-type: none"> a. Transformer connections to bridge network (D101 thru D104). b. Bridge network. c. C102. 2. Q103 or its associated foil is shorted. 3. Q101 and/or Q102 defective. 4. C103 and/or C105 defective.
M	Meter reads less than 2.	<ol style="list-style-type: none"> 1. D102 and/or D101 defective. 2. C107 defective. 3. Transformer improperly connected.
N	Meter reads greater than 2.	<ol style="list-style-type: none"> 1. Q104 or its associated foil is shorted. 2. Q105 or its associated foil is shorted. 3. Q106 or its associated foil is shorted. 4. Q107 is defective.
	Meter reads less than 1.	<ol style="list-style-type: none"> 1. Q104 defective. 2. Q105 defective. 3. Q106 defective. 4. Q107 or its associated foil is shorted. 5. C111 is defective.

STEP	INDICATION	POSSIBLE CAUSE
O	Meter reads greater than 2.5.	1. Q108 or its associated foil is shorted. 2. Q109 or its associated foil is shorted. 3. Q111 or its associated foil is shorted. 4. Q112 is defective.
	Meter reads less than 1.8.	1. Q108 is defective. 2. Q109 is defective. 3. Q111 is defective. 4. C113 is defective.
P	Meter reads less than 3.5.	1. D51 and/or D52 defective.
	Meter reads greater than 4.5.	1. Transformer improperly connected.

TEST CHART 2

PROGRAMMER AND DATA MULTIPLEX CIRCUITS

NOTE: It is necessary that the keyboard circuits are working properly before you perform the following steps. (Refer to chart 11 on Page 183.)

- () Press the POWER ON button to the off (out) position.
- () Remove the programmer circuit board from the chassis.
- () Connect the extender circuit board to the programmer circuit board.
- () Install the board combination.
- () Set the METER switch to the TEST position.
- () Set the RANGE switch to the 15 Vdc position.
- () Press the KEYBOARD button to the ON (in) position.
- () Press the POWER ON button to the ON (in) position.
- () Press the RESET key and perform the measurement in the following chart.

CONNECT BLACK TEST LEAD TO:	CONNECT RED TEST LEAD TO:	METER SHOULD READ:	POSSIBLE CAUSE OF TROUBLE:
GND pin.	Collector (C) of Q201 or collector side of R211 (1000 Ω).		D201; D202; D203; D204; IC201, Q201.

Note the meter reading. Then press any of the numbered keys four times. The meter indication should go to 0 as the first number is depressed and remain there as the other three numbers are depressed. Then press the RESET key. This should cause the meter to return to its original position.



- () Be sure the two plugs on the small cable assembly from the Master circuit board are installed correctly on the Programmer circuit board.
- () Perform the measurements in the following chart.
NOTE: Connect the red test lead to the test points indicated. They are located at the top edge of the Programmer circuit board at the two cable assembly connectors.

CONNECT BLACK TEST LEAD TO:	DEPRESS KEYBOARD KEY NUMBER:	CONNECT RED TEST LEAD TO:	METER SHOULD READ:	POSSIBLE CAUSE OF TROUBLE:
GND pin.	#1	C1 B1 A1		IC1 through IC4 on master circuit board. (Data Multiplex.) Refer to Schematic on Page 227.
		All others		
	#2	D2 C2 B2		
		All others		
	#4	D4 C4 B4		
		All others		
	#8	D8 C8 B8		
		All others		

() Perform the measurements in the following chart.
 NOTE: Connect the red test lead to the test points indicated on the Master circuit board at the Programmer circuit board location.

CONNECT BLACK TEST LEAD TO:	DEPRESS KEYBOARD KEY NUMBER:	CONNECT RED TEST LEAD TO:	METER SHOULD READ:	POSSIBLE CAUSE OF TROUBLE:	
GND pin.	#1 only. Then #0 only. Then none.	A _A		IC1 and/or Q1 on master circuit board. (Data Multiplex.) Refer to Schematic on Page 227.	
		$\overline{A_A}$			
	#2, #3, #4, #5, #6, #7, #8, and then #9.	A _A			
		$\overline{A_A}$			
	Hold down Key #1 and press the reset key. Release both keys.	A ₁ B ₁ C ₁			Refer to the Programmer Schematic (fold-out from Page 200). Check IC's 202, 203, 204, and 205; whichever have outputs that correspond to an incorrect reading.
		B ₂ , B ₄ , B ₈ , C ₂ , C ₄ , C ₈ D ₂ , D ₄ , D ₈			
Hold down key #6 and press the Reset key. Release both keys.	B ₂ , B ₄ , C ₂ C ₄ , D ₂ , D ₄				
	A ₁ , B ₁ , B ₈ C ₁ , C ₈ , D ₈				
Hold down key #8 and press the Reset key. Release both keys.	B ₈ , C ₈ , D ₈				
	A ₁ B ₁ , B ₂ , B ₄ C ₁ , C ₂ , C ₄ D ₂ , D ₄				

- () Press the RESET key. The readout should be 00.1 MHz.
- () Use the keyboard and program in the frequency indicated in the chart below and perform the corresponding measurements.

CONNECT BLACK TEST LEAD TO:	FREQUENCY READOUT:	CONNECT RED TEST LEAD TO:	METER SHOULD READ:	POSSIBLE CAUSE OF TROUBLE:
GND pin.	88.1 MHz	IC207, pin 3		IC207
	87.9 MHz			

- () Connect a 2" wire from the STOP test point at the programmer circuit board location on the master circuit board to chassis ground.
- () Perform the measurements in the following chart.

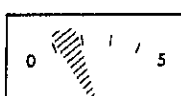
CONNECT BLACK TEST LEAD TO:	CONNECT RED TEST LEAD TO:	DEPRESS KEYBOARD KEY NUMBER:	METER SHOULD READ:	POSSIBLE CAUSE OF TROUBLE:
GND pin.	SWP STOP (At OSC, DIV, GEN circuit board location on master circuit board.)	NONE		IC210
		Bypass key held down		



Press the POWER ON button to the off (out) position.

- () Remove the 2" wire from the STOP test point and discard it.

TEST CHART 3

LEFT CHANNEL MULTIPLEX (MPX-DEMODO)
CIRCUIT

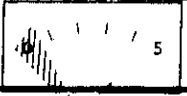

- () Remove the PLL-multiplex demodulator circuit board from the chassis.
- () Connect the extender circuit board to the multiplex circuit board.
- () Install the board combination.
- () Set the METER switch in the TEST position.
- () Set the RANGE switch in the 15 Vdc position.
- () Press the SQUELCH DEFEAT button to the ON (in) position.
- () Press the KEYBOARD mode button.
- () Press the POWER ON button to the ON (in) position.
- () Enter a frequency on the keyboard (for instance, 88.1).
- () Perform the measurements in the following chart.
- () Be sure the RE-PROGRAM light is not on.

CONNECT BLACK TEST LEAD TO:	CONNECT RED TEST LEAD TO:	METER SHOULD READ:	POSSIBLE CAUSE OF TROUBLE:
GND pin.	Emitter (E) of Q707.		Q707; C714. Check for an open or short in associated foils.
	Collector (C) of Q709.		Q709.
	Collector (C) of Q704.		Q701; Q702; Q704; R713; R712; R715; R718; R719; R722.
	Collector (C) of Q711.		Q711.

NOTE: If the preceding measurements check good, check D702 and D703. If both of these diodes check good, C701 or IC701 may be faulty.

TEST CHART 4
**RIGHT CHANNEL MULTIPLEX (MPX-DEM0D)
CIRCUIT**

- () Press the POWER ON button to the off (out) position.
- () Remove the PLL-multiplex demodulator circuit board from the chassis.
- () Connect the extender circuit board to the PLL-multiplex demodulator circuit board.
- () Install the board combination.
- () Set the METER switch in the TEST position.
- () Set the RANGE switch in the 15 Vdc position.
- () Press the SQUELCH DEFEAT switch to the ON (in) position.
- () Press the KEYBOARD mode button.
- () Press the POWER ON button to the ON (in) position.
- () Enter a frequency on the keyboard (for instance, 88.1).
- () Perform the measurements in the following chart.
- () Be sure the RE-PROGRAM light is not on.

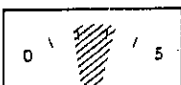
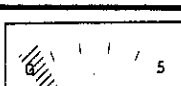
CONNECT BLACK TEST LEAD TO:	CONNECT RED TEST LEAD TO:	METER SHOULD READ:	POSSIBLE CAUSE OF TROUBLE:
GND pin.	Emitter (E) of Q708.		Q708; C715.
	Collector (C) of Q709.		Q709.
	Collector (C) of Q703.		Q701; Q702; R711; R709; R716; R717; R714; R721.
	Collector (C) of Q711.		Q711.



NOTE: If the preceding measurements check good, check D701 and D703. If both of these diodes check good, C701 or IC701 may be faulty.

TEST CHART 5

MULTIPLEX (MPX-DEMOD) CIRCUIT

- () Press the POWER ON button to the off (out) position.
- () Remove the PLL-multiplex demodulator circuit board from the chassis.
- () Connect the extender circuit board to the PLL-multiplex demodulator circuit board.
- () Install the board combination.
- () Set the METER switch in the TEST position.
- () Set the RANGE switch in the 15 Vdc position.
- () Press the KEYBOARD button.
- () Press the POWER ON button to the ON (in) position.
- () Use the keyboard to select a strong local station.
- () Perform the measurements in the following chart.

NOTE: Be sure that the SQUELCH DEFEAT and STEREO ONLY buttons are in the off (out) position for the following measurements.

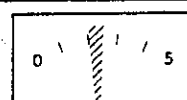
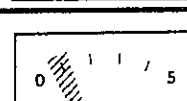
CONNECT BLACK TEST LEAD TO:	CONNECT RED TEST LEAD TO:	METER SHOULD READ:	POSSIBLE CAUSE OF TROUBLE:
GND pin.	Pin 1 of IC702.		STEREO ONLY switch wiring; IC702.
	Pin 2 of IC702.		KEYBOARD switch wiring.
	Pin 4 of IC702.		Q716; Q717; IC606; Q601; D611 and/or D609; L602 not adjusted.
	Pin 5 of IC702.		Q714; D712; D711; Q713; Q712; NOISE SQUELCH control wiring.

TEST CHART 6

AUTO-SWEEP PULSE GENERATOR CIRCUIT

- () Install the board combination.
- () Set the METER switch in the TEST position.
- () Press the POWER ON button to the off (out) position.
- () Set the RANGE switch in the 15 Vdc position.
- () Remove the generator-divider-oscillator (GEN-DIV-OSC) circuit board from the chassis.
- () Press the KEYBOARD button to the ON (in) position.
- () Press the POWER ON button to the ON (in) position.
- () Connect the extender circuit board to this circuit board.
- () Perform the measurements in the following chart.

CONNECT BLACK TEST LEAD TO:	CONNECT RED TEST LEAD TO:	METER SHOULD READ:	POSSIBLE CAUSE OF TROUBLE:
GND pin.	+5V pin		Faulty connector. Proceed to Test Chart 1 on Page 170.
	Pins 12, 13, and 14 of IC408.		Harness wiring error or associated with +5V (SW) red lead and switch assembly.

- () Press the PREPROGRAMMED switch to the ON (in) position.

GND pin.	Pins 12, 13, and 14 of IC408.		Preprogram switch; wiring error.
----------	-------------------------------	--	----------------------------------

NOTE: In the following steps it may be necessary to repeatedly press the BYPASS button to prevent the pulse generator from stopping on strong signals.

- () Press the AUTO-SWEEP switch to the ON (in) position.

GND pin.	Pins 12 and 13 of IC408.		IC408 or a faulty solder connection.
----------	--------------------------	--	--------------------------------------

- () Turn the SWEEP SPEED control full counterclockwise.

GND pin.	Positive (+) side of C402. (Refer to the "X-Ray View" on Page 218.)	 Oscillate from 0 to 1.5 about once each second.	R51; wiring error or IC408.
----------	---	---	-----------------------------

- () Turn the SWEEP SPEED control fully clockwise.

GND pin.	Positive (+) side of C402.	 Rapid oscillation.	R51; wiring error.
----------	----------------------------	------------------------	--------------------



TEST CHART 7

PHASE DETECTOR AND LOOP FILTER CIRCUIT

- () Install the board combination.
- () Set the METER switch in the TEST position.
- () Press the POWER ON button to the off (out) position.
- () Set the RANGE switch in the 15 Vdc position.
- () Remove the tuner circuit board from the chassis.
- () Press the KEYBOARD switch to the ON (in) position.
- () Connect the extender circuit board to the tuner circuit board.
- () Press the POWER ON button to the ON (in) position.
- () Perform the measurements in the following chart.

CONNECT BLACK TEST LEAD TO:	CONNECT RED TEST LEAD TO:	METER SHOULD READ:	POSSIBLE CAUSE OF TROUBLE:
GND pin.	Pin 3 of IC505.		Output from programmable divider network. Proceed to Test Chart 9.
	Pin 1 of IC505.		Output from the divide-by-4 reference divider. Proceed to Test Chart 9.
NOTE: The remaining measurements should be taken with a front panel readout of 00.1 MHz.			
GND pin.	Pin 2 of IC505.		IC505.
	Pin 13 of IC505.		IC505.
	Pin 12 of IC505.		IC505.
	Pin 6 of IC505.		IC505.
	Pin 8 of IC505.		IC505.

- () Press the AUTO SWEEP switch to the ON (in) position.
- () Set the AUTO SWEEP SPEED control to approximately midrange.

GND pin.	Collector (C) of Q503 or collector end of R514.	As the Tuner Automatically sweeps down from 107.8 MHz to 88.1 MHz, the meter should begin near full scale and decrease in discrete steps to the lower 1/3 of the scale.	Q502; Q503.
----------	---	---	-------------

NOTE: If the preceding measurements check good but the UNLOCKED light remains ON, check Q504 and Q505.

() Connect the extender circuit board to this circuit board.

TEST CHART 8

100 kHz CRYSTAL OSCILLATOR AND DIVIDE-BY-4 REFERENCE SCALER CIRCUIT

() Install the board combination.

() Set the METER switch in the TEST position.

() Press the POWER ON button to the off (out) position.

() Set the RANGE switch to the 15 Vdc position.

() Remove the tuner-PLL circuit board from the chassis.

() Press the POWER ON button to the ON (in) position.

() Remove the generator-divider-oscillator (GEN-DIV-OSC) circuit board from the chassis.

() Perform the measurements in the following chart.

CONNECT BLACK TEST LEAD TO:	CONNECT RED TEST LEAD TO:	METER SHOULD READ:	POSSIBLE CAUSE OF TROUBLE
GND pin.	+5V pin.		Faulty connector. Proceed to Test Chart 1.
	25 kHz OUT pin.		Continue with the remaining measurements on this chart.
NOTE: If the above measurements are correct, the 100 kHz Crystal Oscillator and Divide-By-4 Reference Scaler is assumed to be operating.			
GND pin.	Pin 14 of IC401.		Check for an open or short in associated foil. Check for an open in R404.
	Pin 1 of IC401.		IC401; Y401; C407; C406; C408; C409; R407; R406; R405; R408.
	Pin 6 of IC402.		Check for an open or short in associated foil; IC401 or IC402.
	Pin 12 of IC402.		IC402.

TEST CHART 9

PROGRAMMABLE DIVIDER CIRCUIT

- () Press the POWER ON button to the off (out) position.
- () Be sure the tuner-PLL circuit board is properly installed.
- () Remove the generator-divider-oscillator (GEN-DIV-OSC) circuit board from the chassis.
- () Connect the extender circuit board to this circuit board.
- () Install the board combination.
- () Set the METER switch in the TEST position.
- () Set the RANGE switch in the 15 Vdc position.
- () Press the KEYBOARD switch to the ON (in) position.
- () Press the POWER ON button to the ON (in) position.
- () Check to see that the readout display goes to 00.1 MHz. Leave the readout at this frequency while performing the measurements in the following chart.
- () Perform the measurements in the following chart.

CONNECT BLACK TEST LEAD TO:	CONNECT RED TEST LEAD TO:	METER SHOULD READ:	POSSIBLE CAUSE OF TROUBLE:
GND pin.	+5V pin.		Faulty connector. Proceed to Test Chart 1.
	Pin 5 of IC406.	 Slightly above 0.	IC406; IC405. No VCO output from the tuner-PLL circuit board.
	Pin 3 of IC406.		IC405; IC404.
	Pin 2 of IC406.		IC403; IC404; IC406.
	Pin 10 of IC406.		IC403; IC404; IC405; IC407.

TEST CHART 10

FM TUNER AND VCO FREQUENCY SCALER

- () Press the POWER ON button to the OFF (out) position.
- () Set the METER switch in the TEST position.
- () Set the RANGE switch in the 15 Vdc position.
- () Press the POWER ON button to the ON (in) position.
- () Perform the measurement in the following chart.

CONNECT BLACK TEST LEAD TO:	CONNECT RED TEST LEAD TO:	METER SHOULD READ:	POSSIBLE CAUSE OF TROUBLE:
GND (Upper support rail).	VCO OUT terminal (on master circuit board at Tuner).		The fm tuner; IC501; IC502; IC503; IC504.









TEST CHART 11
KEYBOARD CIRCUIT







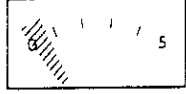

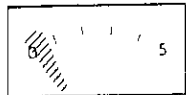
- () Press the POWER ON button to the OFF (out) position.
- () Remove the four screws (two on each side) holding the front panel assembly to the chassis.
- () Position the front panel assembly as shown in Figure 1-1 (fold-out from Page 122), so you can watch the meter and operate the Keyboard buttons.

- () Set the METER switch in the TEST position.
- () Set the RANGE switch in the 15 Vdc position.
- () Press the KEYBOARD button to the ON (in) position.
- () Press the POWER ON button to the ON (in) position.
- () Perform the measurements in the following chart.

NOTE: Refer to the "Keyboard Circuit Board" X-Ray View on Page 223 for the test point locations.

CONNECT BLACK TEST LEAD TO:	CONNECT RED TEST LEAD TO:	METER SHOULD READ:	POSSIBLE CAUSE OF TROUBLE:
Any GND pin, or chassis.	+5V pin.		Faulty connection. Proceed to Test Chart 1.
	L1. L2. L4. L8.		Faulty wiring; diodes installed incorrectly.
	L1.	 With Key 1 pressed.	S54; S801.
	L1.	 With Key 3 pressed.	S803; D801.
	L1.	 With Key 5 pressed.	S805; D803.
	L1.	 With Key 7 pressed.	S807; D807.

CONNECT BLACK TEST LEAD TO:	CONNECT RED TEST LEAD TO:	METER SHOULD READ:	POSSIBLE CAUSE OF TROUBLE:
Any GND pin, or chassis.	L1.	 With Key 9 pressed.	S809; D812.
	L2.	 With Key 2 pressed.	S802.
	L2.	 With Key 3 pressed.	S801; D802.
	L2.	 With Key 6 pressed.	S806; D805.
	L2.	 With Key 7 pressed.	D808.
	L4.	 With Key 4 pressed.	S804.
	L4.	 With Key 5 pressed.	D804.
	L4.	 With Key 6 pressed.	D806.
	L4.	 With Key 7 pressed.	D809.
	L8.	 With Key 8 pressed.	S808.

CONNECT BLACK TEST LEAD TO:	CONNECT RED TEST LEAD TO:	METER SHOULD READ:	POSSIBLE CAUSE OF TROUBLE:
Any GND pin, or chassis.	LB.	 With Key 9 pressed.	S809; D811.
	SHT.	 With Key 1 pressed.	D813; Q801.
	SHT.	 With Key 2 pressed.	D814.
	SHT.	 With Key 4 pressed.	D815.
	SHT.	 With Key 8 pressed.	D816.
	SHT.	 With Key 0 pressed.	S811; R805.
	Positive (+) side of C802.	 With RESET pressed.	S812; R811; C802.
	BPS.	 With no Keys pressed.	S813; R808; R809.
	BPS.	 With BYPASS pressed.	S813; R808; R809; C801.

TEST CHART 12

PRELOAD DECODER CIRCUIT

NOTE: It is necessary that the keyboard and programmer circuits are working properly before you perform the following steps.



- () Press the POWER ON button to the off (out) position.
- () Connect the extender circuit board to the preload decoder circuit board.
- () Install the board combination at the Preload Decoder circuit board location.

- () Set the METER switch to the TEST position.
- () Set the RANGE switch to the 15 Vdc position.
- () Press the KEYBOARD button to the ON (in) position.
- () Press the POWER ON button to the ON (in) position.
- () Use the Keyboard and program 96.9 MHz.
- () Perform the measurements in the following chart.



NOTE: All of the measurements called for in the following chart are made on the master circuit board at the OSC-DIV-GEN circuit board location.

CONNECT BLACK TEST LEAD TO:	CONNECT RED TEST LEAD TO:	METER SHOULD READ:	POSSIBLE CAUSE OF TROUBLE:
GND pin or chassis.	+5.		Faulty connection. Proceed to Test Chart 1.
	PD ₄ PC ₁ PC ₈ PB ₁ .		Refer to the preload decoder schematic (fold-out from Page 204). Check all IC's and circuitry connected with any output pin having an incorrect reading.
	PD ₁ PD ₂ PD ₈ PC ₂ PC ₄ PB ₂ RE-PGM.		

- () Press the RESET button to clear the readout display.
- () Use the Keyboard to program 89.3 MHz.
- () Perform the measurements in the following chart.

CONNECT BLACK TEST LEAD TO:	CONNECT RED TEST LEAD TO:	METER SHOULD READ:	POSSIBLE CAUSE OF TROUBLE:
GND pin or chassis.	PD ₂ .		Refer to the preload decoder schematic (fold-out from Page 204). Check all IC's and circuitry connected with any output pin having an incorrect reading.
	PD ₄ .		
PC ₁ .			
PC ₄ .			
PB ₁			
PD ₁ .			
PD ₈ .			
PC ₂ .			
PC ₈ .			
PB ₂ .			
	RE-PGM.		

- () Press the RESET button to clear the readout display. () Perform the measurements in the following chart.
- () Use the Keyboard to program 102.7 MHz.

CONNECT BLACK TEST LEAD TO:	CONNECT RED TEST LEAD TO:	METER SHOULD READ:	POSSIBLE CAUSE OF TROUBLE:
GND pin or chassis.	PD ₁ .		Refer to the preload decoder schematic (fold-out from Page 204). Check all IC's and circuitry connected with any output pin having an incorrect reading.
	PD ₂ .		
PC ₂ .			
PB ₂ .			
PD ₄ .			
PD ₈ .			
PC ₁ .			
PC ₄ .			
PC ₈ .			
PB ₁ .			
	RE-PGM		

ALIGNMENT WITH INSTRUMENTS

NOTE: The fm tuning unit (varactor tuner) was carefully prealigned at the factory.

Do not attempt to realign the fm tuning unit unless you have all of the following:

- *Ample proof indicating that a misalignment exists.*
- *An understanding of the tuning unit and a thorough knowledge of the theory involved.*
- *Complete knowledge of instrument alignment procedures.*
- *The special precision equipment listed below.*

Precision fm stereo generator — FM Stereo Generator

Type SMG1

Radiometer

Copenhagen, Denmark

(or equivalent)

Precision rf generator — FM-AM Signal Generator

Type 202H

Boonton Radio Company

Rockway, New Jersey

(or equivalent)

Audio Voltmeter.

Frequency Counter (100 MHz).

Adjustable power supply (0 — 20 VDC). Hum and ripple must be less than .5 mV.

Digital voltmeter.

Do not adjust any transformer, coil, or capacitor unless a step instructs you to do so. Always perform the adjustments in the order specified.

The "I-F and Stereo Separation" alignment can be accomplished without performing the "Varactor Tuner

Alignment." However, always perform the "I-F and Stereo Separation" alignment prior to performing the "Varactor Tuner Alignment."

I-F AND STEREO SEPARATION

Refer to Parts A and B of Figure 5-4 for the following steps.

1. Be sure the POWER ON button is in the off (out) position.
2. Unplug the tuner/phase-lock-loop i-f cable from the i-f circuit board.
3. Unplug the antenna push-on connectors from the rear panel.
4. Remove the tuner/phase-lock-loop circuit board from the chassis.
5. Install the extender circuit board in the tuner/phase-lock-loop circuit board location.
6. Install the tuner/phase-lock-loop circuit board on the extender circuit board.
7. Connect the extender cable between the tuner/phase-lock-loop i-f cable and the phono socket on the i-f circuit board.
8. Connect the fm stereo generator to the antenna leads coming from the tuner/phase-lock-loop circuit board.
9. Adjust the fm stereo generator to provide the following output:
 - 100.5 MHz, ± 5 kHz;
 - 1 kHz, 100% modulation;
 - left channel only.

Use the frequency counter to accurately set the frequency.
10. Press the POWER ON button to the ON (in) position.
11. Press the SQUELCH DEFEAT button to the ON (in) position.
12. Set the METER switch to the NORM (normal) position.

13. Set the AGC SQUELCH control fully counterclockwise.
 14. Press the KEYBOARD button to the ON (in) position.
 15. Key in 100.5 MHz on the KEYBOARD.
 16. Adjust the fm stereo generator output level to place the signal meter pointer just above midscale. Readjust the generator as necessary to maintain this midscale indication throughout the following steps.
 17. Refer to Part A and Part B of Figure 5-4 and adjust the top and bottom slugs of i-f transformer T553 for maximum signal meter indication.
 18. Adjust the fm stereo generator output for 1000 μ V.
 19. Connect an audio voltmeter between the RIGHT CHANNEL output on the rear panel and the chassis.
 20. Refer to Part B of Figure 5-4 and turn the SEPARATION ADJUST control (located on the PLL/multiplex/demodulator circuit board) counterclockwise until the STEREO lamp just goes out. Turn the control clockwise until the STEREO lamp just lights; then continue turning it clockwise for minimum signal (less than 10 mV) on the audio voltmeter.
 21. Disconnect the audio voltmeter.
 22. Disconnect the fm stereo generator.
- NOTE: If you are going to perform the varactor tuner alignment, disregard the following six steps; 23 through 28.
23. Press the POWER ON button to the off (out) position.
 24. Unplug the extender cable and set it aside.
 25. Remove the tuner/phase-lock-loop circuit board from the extender circuit board.
 26. Remove the extender circuit board from the chassis.
 27. Install the tuner/phase-lock-loop circuit board in the chassis.
 28. Connect the tuner/phase-lock-loop i-f cable to the phono socket on the i-f circuit board.
 29. Connect the antenna push-on connectors to the antenna terminals on the rear panel.

VARACTOR TUNER ALIGNMENT

Be sure the "I-F and Stereo Separation" alignment has been completed before proceeding.

30. Refer to Part B of Figure 5-4 and unsolder and remove the bottom end of the 18 k Ω (brown-gray-orange) resistor (R514) from the tuner/phase-lock-loop circuit board.
 31. Connect the rf signal generator to the antenna leads coming from the tuner/phase-lock-loop circuit board.
 32. Adjust the rf signal generator to 90 MHz.
 33. Connect the digital voltmeter to the output of the auxiliary power supply. Leave the voltmeter connected throughout the remaining steps. It will be used to monitor the power supply voltage.
 34. Adjust the power supply output for exactly 4.78 volts dc.
- CAUTION: Be sure the POWER ON button is always in the ON (in) position before you connect the auxiliary power supply leads to the 18 k Ω resistor. Likewise, always disconnect the auxiliary power supply leads before you press the POWER ON button to the off (out) position.
35. Press the POWER ON button to the ON (in) position.
 36. Connect the common (ground) power supply lead to the Tuner chassis.
 37. Connect the positive lead to the free end of the 18 k Ω resistor on the tuner/phase-lock-loop circuit board.
- NOTE: Oscillator trimmer capacitor C584 does not require adjustment. However, if this trimmer has been turned or adjusted, return it to its midrange position.
38. Adjust the rf signal generator output level to place the signal meter pointer just above midscale. Readjust the generator as necessary to maintain this midscale indication level throughout the following steps.
 39. Adjust the oscillator transformer T554 for maximum signal meter indication.
 40. Adjust the antenna transformer T551 and interstage coils L552 and L554 for maximum signal meter deflection.

41. Repeat the previous step until no further increase in the signal meter indication can be obtained.
 42. Set the rf signal generator to 106 MHz.
- CAUTION: When you adjust the auxiliary power supply voltage in any of the following steps, do not exceed 18 volts dc.
43. Carefully adjust the power supply voltage for maximum signal meter indication.
 44. Adjust the antenna trimmer, C552, and interstage trimmers C564 and C571 for maximum signal meter indication.
 45. Adjust the power supply voltage for exactly 4.78 volts dc.
 46. Set the rf signal generator to 90 MHz.
 47. Repeat steps 38 through 44 until no further increase in the signal meter indication can be obtained.
 48. Set the rf signal generator to 98 MHz.
 49. Carefully adjust the power supply voltage for maximum signal meter indication.
 50. Adjust the rf signal generator output level to obtain full-scale signal meter indication.
- NOTE: The following neutralizing adjustment is quite broad and will have very little effect on the signal meter indication. You may skip this adjustment if you wish as it is not necessary to the proper operation of the tuner.
51. Adjust neutralizing capacitor C557 for minimum signal meter indication.
 52. Adjust the power supply voltage for exactly 4.78 volts dc.
 53. Set the rf signal generator to 90 MHz.
 54. Repeat steps 38 through 44 until no further increase in the signal meter indication can be obtained.
 55. Set the rf signal generator to 87.75 MHz.
 56. Adjust the power supply voltage for maximum signal meter indication. This voltage must be 3.8 volts or greater.
 57. Set the rf signal generator to 108.25 MHz.
 58. Adjust the power supply voltage for maximum signal meter indication. This voltage must be 18.0 volts or less.
 59. Set the rf signal generator to 98 MHz.
 60. Adjust the power supply voltage for maximum signal meter indication. This voltage must be between 7.0 and 8.3 volts.
 61. Disconnect the power supply for the 18 k Ω resistor on the tuner/phase-lock-loop circuit board.
 62. Press the POWER ON button to the off (out) position.
 63. Disconnect the rf signal generator from the antenna leads.
 64. Unplug the extender cable and set it aside.
 65. Remove the tuner/phase-lock-loop circuit board from the extender circuit board.
 66. Reconnect the 18 k Ω resistor (R514) to the tuner/phase-lock-loop circuit board.
 67. Remove the extender circuit board from the chassis.
 68. Install the tuner/phase-lock-loop circuit board in the chassis.
 69. Connect the tuner/phase-lock-loop i-f cable to the phono socket on the i-f circuit board.
 70. Connect the antenna push-on connectors to the antenna terminals on the rear panel.
- This completes "Alignment With Instruments."

FACTORY REPAIR SERVICE

Heathkit repair facilities are available to you for particular circuit board modules or for your complete Tuner. These services are described below under the headings "Module Repair Service" and "Kit Repair Service." You may also avail yourself of the assistance of our trained technical correspondents by letter or telephone.

MODULE REPAIR SERVICE

Ten of the circuit boards in this Tuner contain most of the electronic circuits. Seven of these circuit boards are plug-in units and will be referred to as modules. Any of these modules may be quickly removed for inspection or service. This service policy applies to only the following circuit board modules:

- Power Supply Circuit Board Module
- Programmer Circuit Board Module
- Preload Decoder Circuit Board Module
- Generator-Divider-Oscillator Circuit Board Module
- Tuner/Phase-Lock-Loop Circuit Board Module
- I-F Circuit Board Module
- Multiplex Circuit Board Module

Special service facilities have been established at our factory and at Heathkit Electronic Centers to provide you with quick service and return of modules. After isolating troubles to a particular module(s), you may return the module(s) for repair under the terms of this policy. Every effort will be made to repair the module and have it enroute to you within 48 hours (two working days) after it is received at the Heath service facility.

IN WARRANTY — In addition to our standard 90 day kit warranty, any of the above modules requiring service and returned to a Heath service facility will be serviced or replaced with no charge for labor or parts.

OUT OF WARRANTY — After the standard 90 day kit warranty expires, any of the above modules requiring service and returned to a Heath service facility will be serviced or replaced at a fixed charge of \$5.00 per module, including labor and parts.

How to Return Modules

A special "Module Service" carton (red in color) has been included with your kit. Save this carton and some loose packing material. Then, if at any time it becomes necessary to return a module(s), pack the module(s) carefully in this easily-identified carton to assure yourself of rapid service. Include the following information in the pack:

1. A letter describing the difficulties in your Tuner.
2. The chassis series number (on the blue and white label).
3. Date of purchase and invoice number.
4. Your check or money order covering service fees (\$5.00 per module) for "out-of-90-day warranty" service.
5. Ship the carton by insured parcel post to "Heath Company, Benton Harbor, Michigan 49022," or to any one of the Heathkit Electronic Centers listed in the current Heathkit catalog.

This service policy applies only to those plug-in circuit board modules listed above. If the problem appears to be somewhere other than on one of the listed modules, please check with our Technical Correspondence Section or your nearest Heathkit Electronic Center before returning the Kit for service.

KIT REPAIR SERVICE

See inside the rear cover of the Manual.



REPLACEMENT PARTS AND PRICE INFORMATION

To order a replacement part: Use the Parts Order Form furnished with this kit. If one is not available, see "Replacement Parts" inside the rear cover of the Manual.

The prices in the Parts Lists apply only on purchases from the Heath Company where shipment is to a U.S.A.

destination. Add 10% (minimum 25 cents) to the price when ordering (Michigan residents add 4% sales tax) to cover insurance, postage, and handling. Outside the U.S.A. parts and service are available from your local Heathkit source and will reflect additional transportation, taxes, duties, and rates of exchange.

SPECIFICATIONS

TUNER

MONOPHONIC

Exact Tuning Range	88.1 to 107.9 MHz.
Tuning	Digitally synthesized.
Intermediate Frequency	10.7 MHz.
Antenna	75 Ω or 300 Ω .
Frequency Response	
Discriminator	10 - 60,000 Hz, ± 5 dB.
Audio	20 to 15,000 Hz, ± 1 dB.
Sensitivity	Less than 1.8 μ V.*
Selectivity (Alternate Channel)	Greater than 95 dB.*
Capture Ratio	Less than 1.5 dB.*
Harmonic Distortion	Less than 0.3%.*
Intermodulation Distortion	Less than 0.1%.*
Image Rejection	Greater than 90 dB.*
I-F Rejection	Greater than 90 dB.*
Spurious Rejection	Greater than 90 dB.*

*Rated IHF (Institute of High Fidelity) Standards.



Signal to Noise Ratio (100% modulation)	Greater than 65 dB.*
A-M Suppression	Greater than 60 dB.*
Channel Frequency Accuracy	Better than 0.005%.

STEREOPHONIC

Channel Separation	1000 Hz, 40 dB. 80 Hz, 30 dB. 10 kHz, 30 dB. 15 kHz, 25 dB.
Harmonic Distortion (100% modulation)	Less than 0.35%.
Frequency Response	±1 dB, 20 to 15,000 Hz.
19 kHz and 38 kHz Suppression	Greater than 60 dB.
SCA Suppression	Greater than 60 dB.

AUDIO OUTPUT

Output Voltage (with 100% modulation)	1.0 volts rms nominal.
Output Impedance	4700 Ω nominal.

SCOPE OUTPUTS

Horizontal	0 V to 1.0 V peak-to-peak nominal (100% modulation).
Vertical	0 V to 3.0 V DC nominal (full limiting).

GENERAL

Power Requirements	105-125 or 210-250 volts 50/60 Hz ac. Power consumption 50 W maximum.
AC Outlet	Unswitched, 350 W maximum.
Mounting	Cabinet, shelf, wall, or panel.
Dimensions Overall	6" high, 16-3/8" wide, 14-3/4" deep.
Net Weight	15 lbs. 12 oz.

*Rated IHF (Institute of High Fidelity) Standards.

The Heath Company reserves the right to discontinue products and to change specifications at any time without incurring any obligation to incorporate new features in products previously sold.

CIRCUIT DESCRIPTION

Refer to Schematic Diagrams (fold-out from Pages 199 through Page 210), and to the Block Diagram (fold-out from Page 194), while you read this "Circuit Description."

A Master Schematic Diagram (fold-out from Page 227) shows the master circuit board and the wiring interconnections between the various circuit boards. Refer to the individual schematics for each circuit board (fold-out from Page 199 through Page 210).

To help you locate specific parts in the Tuner or on the Schematic, the circuit part numbers (R1, C101, L301, etc.) for resistors, capacitors, coils, and transistors are in the following groups:

0-49	Parts on the master circuit board.
50-99	Parts on the chassis.
100-199	Parts on the power supply circuit board.
200-299	Parts on the programmer circuit board.
300-399	Parts on the preload decoder circuit board.
400-499	Parts on the generator-divider-oscillator circuit board.
500-599	Parts on the tuner-PLL circuit board.
600-699	Parts on the i-f circuit board.
700-799	Parts on the PLL-multiplexer demodulator circuit board.
800-899	Parts on the keyboard circuit board.
900-999	Parts on the readout circuit board.

The following paragraphs explain the overall circuit functions, briefly, in nontechnical terms. Detailed

descriptions of circuit operation begin with the title "Inputs." This portion of the "Circuit Description" is intended to be informative, but does not attempt to teach the digital techniques used in the Tuner.

FM broadcast signals (88.1 to 107.9 MHz) are received by the antenna and coupled to the tuner. The tuner selects a particular station signal and converts it to an intermediate frequency (i-f) of 10.7 MHz.

The tuning unit differs from ordinary fm tuners in that a mechanical type of tuning is not used. Instead, it is tuned by applying a dc voltage to the tuning unit.

Any one of three types of inputs can tune the Tuner. The keyboard, preprogrammed cards, or automatic sweep, along with the associated circuitry, program a divider circuit. The divider circuit divides the tuner VCO frequency and compares it to a reference frequency. The result of this comparison is the tuning voltage. Changing the divide ratio of the divider circuit changes the dc voltage applied to the tuner and a different station is tuned in. A visual display of the station frequency is provided by the readout circuitry.

Left and right channel signals were produced at the radio station. These signals were then combined with other standard fm signals and transmitted. The received signals from the Tuner tuning circuits are amplified and converted back into an audio signal by the detector circuit. The multiplex demodulator circuits then separate and amplify the left and right channel audio signals.

INPUTS

Each of the three inputs (keyboard, preprogrammed, and auto-sweep) provide electronic digital tuning of the Tuner. A keyboard permits manual frequency selection. Preprogrammed cards provide selective memory tuning. The automatic sweep electronically scans through the fm frequency range seeking stations of a predetermined signal strength.

The desired input selection scheme is activated when the appropriate front panel switch (Keyboard, Auto-Sweep, Preprogrammed) is pressed. These switches are mechanically connected in an exclusive OR configuration where only one input at a time can be selected.

Logic techniques are used to represent the fm station frequencies. The decimal numbers 0 through 9 can be represented by an 8-4-2-1 binary code as follows:

DECIMAL	BINARY
	8 4 2 1
0	0 0 0 0
1	0 0 0 1
2	0 0 1 0
3	0 0 1 1
4	0 1 0 0
5	0 1 0 1
6	0 1 1 0
7	0 1 1 1
8	1 0 0 0
9	1 0 0 1

The fm broadcast band spans from 88.1 MHz to 107.9 MHz. These frequencies, when converted to an 8-4-2-1 binary code, are used to program the Tuner. Since 107.9 is the largest decimal number to be used, it can be expressed as follows:

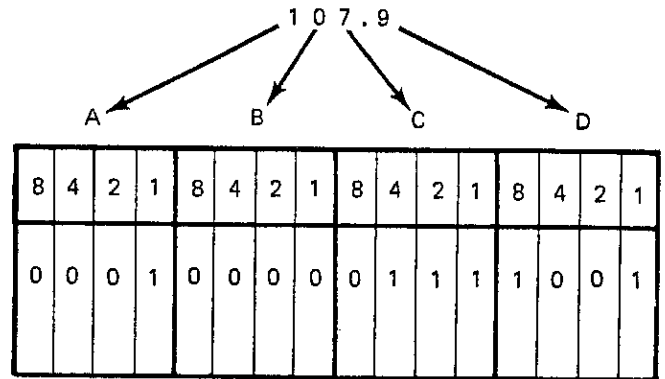

Because the number under column A is never larger than 1, the 8-4-2 in column A is not used.

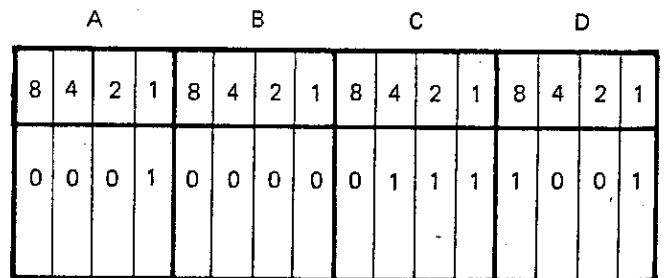

Not Used

The above terms are combined and expressed in the remainder of the Circuit Description as follows:

A₁ B₈ B₄ B₂ B₁ C₈ C₄ C₂ C₁ D₈ D₄ D₂ D₁

All fm frequencies within the commercial fm broadcast band end in an odd digit; that is 1, 3, 5, 7, or 9. Several fm station frequencies are shown below to illustrate the odd digit. Because D_1 is always 1 for all frequencies, it is internally fixed.

	A_1	B_8 B_4 B_2 B_1	C_8 C_4 C_2 C_1	D_8 D_4 D_2	D_1
99.9	0	1 0 0 1	1 0 0 1	1 0 0	1
107.1	1	0 0 0 0	0 1 1 1	0 0 0	1
96.3	0	1 0 0 1	0 1 1 0	0 0 1	1
98.7	0	1 0 0 1	1 0 0 0	0 1 1	1
103.5	1	0 0 0 0	0 0 1 1	0 1 0	1
105.7	1	0 0 0 0	0 1 0 1	0 1 1	1
88.5	0	1 0 0 0	1 0 0 0	0 1 0	1

 INTERNALLY
FIXED

Because both positive and negative logic are used, the terms H (high) and L (low) will be used in the following discussion to distinguish between logic levels. The letter H or the word "high" will be referred to when the voltage level is between +3.2 and +5.2 volts. The letter L or the word "low" will be used when the voltage level is less than +0.8 volts (ground). These H and L designations can be easily converted to 1 and 0 logic levels if desired. For positive logic, let logic 1 = H and logic 0 = L. For negative logic, let logic 1 = L and logic 0 = H.

PREPROGRAM CARD READER

The Preprogram pushbutton switch is pressed to activate the preprogram card readers. One of the three card reader switches (A, B, or C) is pressed to select the desired programmed card.

In its normal state, the card reader contacts remain closed. The plastic preprogram card is inserted into the card reader to open unwanted connections. Notches (cutouts) in the card permit wanted connections to remain closed. Figure 6-1 illustrates how the notches in a preprogrammed card apply the BCD (binary coded decimal) equivalent of the station frequency to the data multiplexer. The D_1 section of a preprogrammed card is not read by the card reader even though it may have been removed when the card was prepared. This is because the D_1 line is always high for all frequencies.

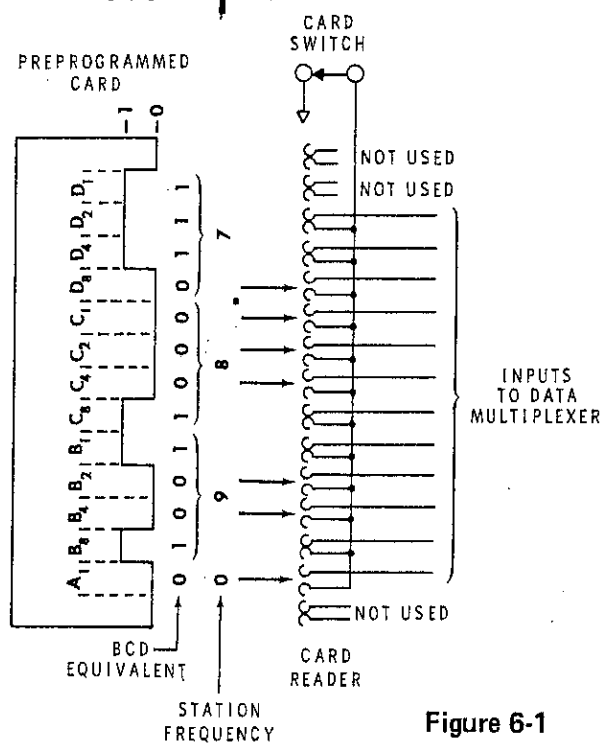

Figure 6-1

KEYBOARD

The Keyboard switch is pressed to complete the ground circuit to the keyboard keys. Diodes D801 through D812 form a diode matrix that converts the keyboard decimal numbers to corresponding BCD (binary coded decimal) outputs. Normally, outputs L_8 , L_4 , L_2 , and L_1 remain high (positive voltage). When one of the ten keys is pressed, the appropriate L outputs are grounded (low) and remain grounded until the key is released.

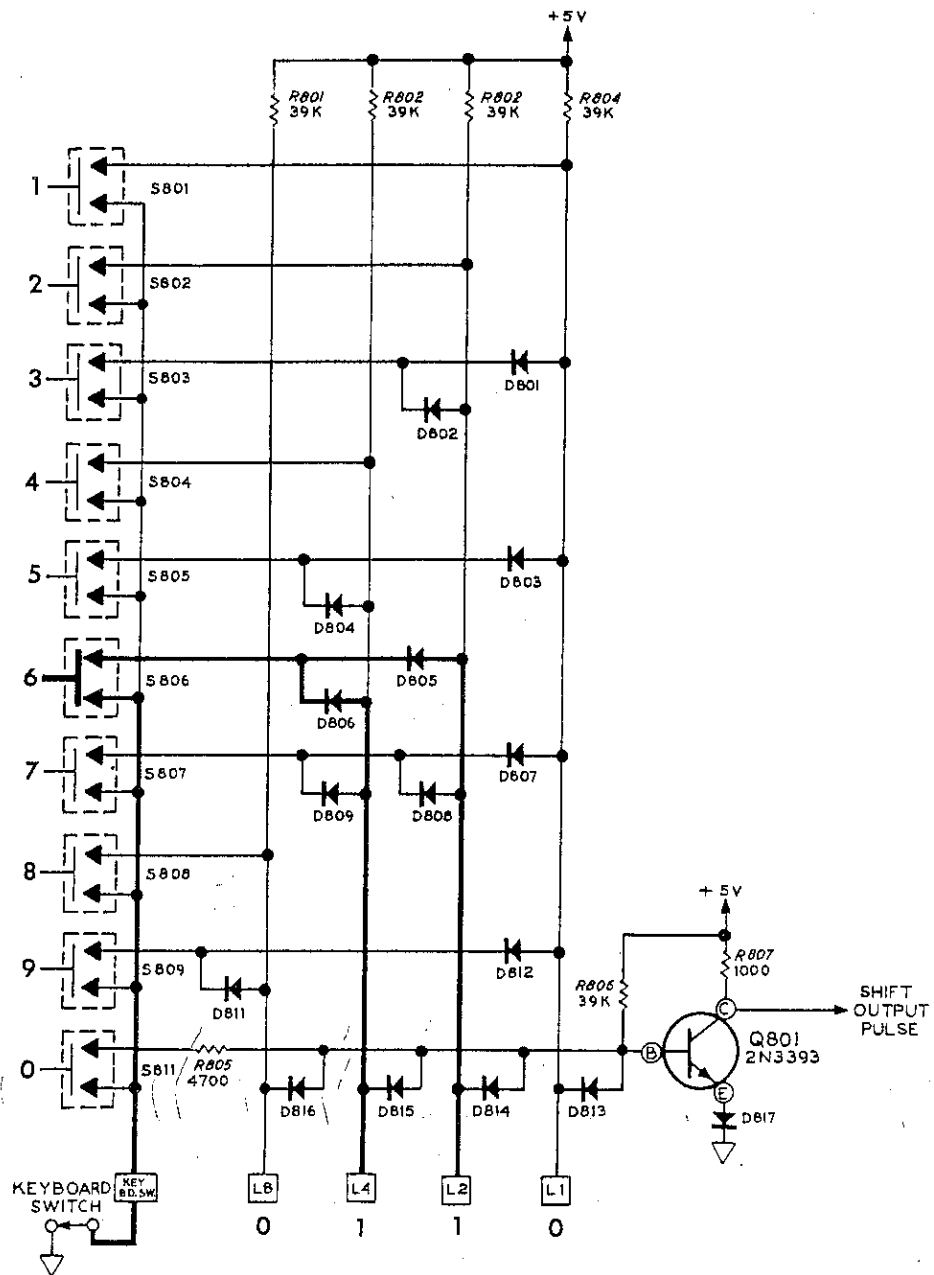

Figure 6-2

Figure 6-2 shows how keyboard key 6 produces a BCD output of $L_8 = \text{high}$, $L_4 = \text{low}$, $L_2 = \text{low}$, and $L_1 = \text{high}$. (These outputs are in negative logic.)

Diodes D813 through D816 and transistor Q801 form a NOR gate circuit. Because Q801 is normally biased to conduct, its output is low. However, when one of the four keyboard outputs is low, or when key 0 is pressed, Q801 is turned off and produces a high (positive voltage) shift signal.

AUTOMATIC SWEEP

The Auto-Sweep switch places a low (ground) on the inputs of several NAND gates in the data multiplexer. It also initiates the count down signal.

Because 107.9 MHz is the highest fm station frequency, it is necessary to start the sweep above this point. The logic signal applied to the NAND gates is the BCD equivalent of 107. (10).

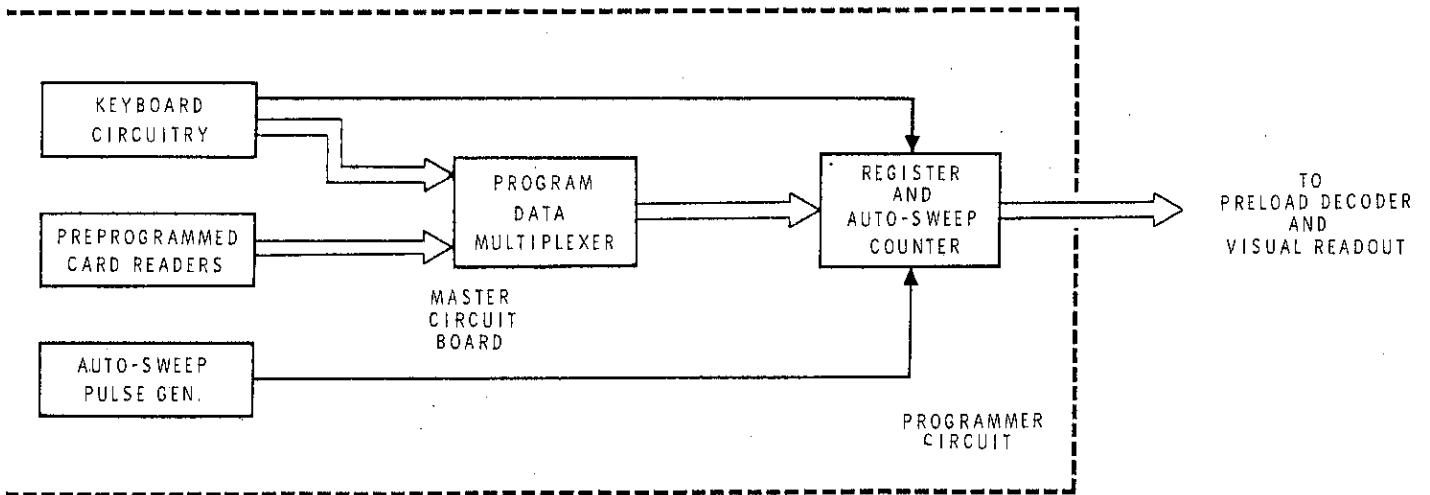
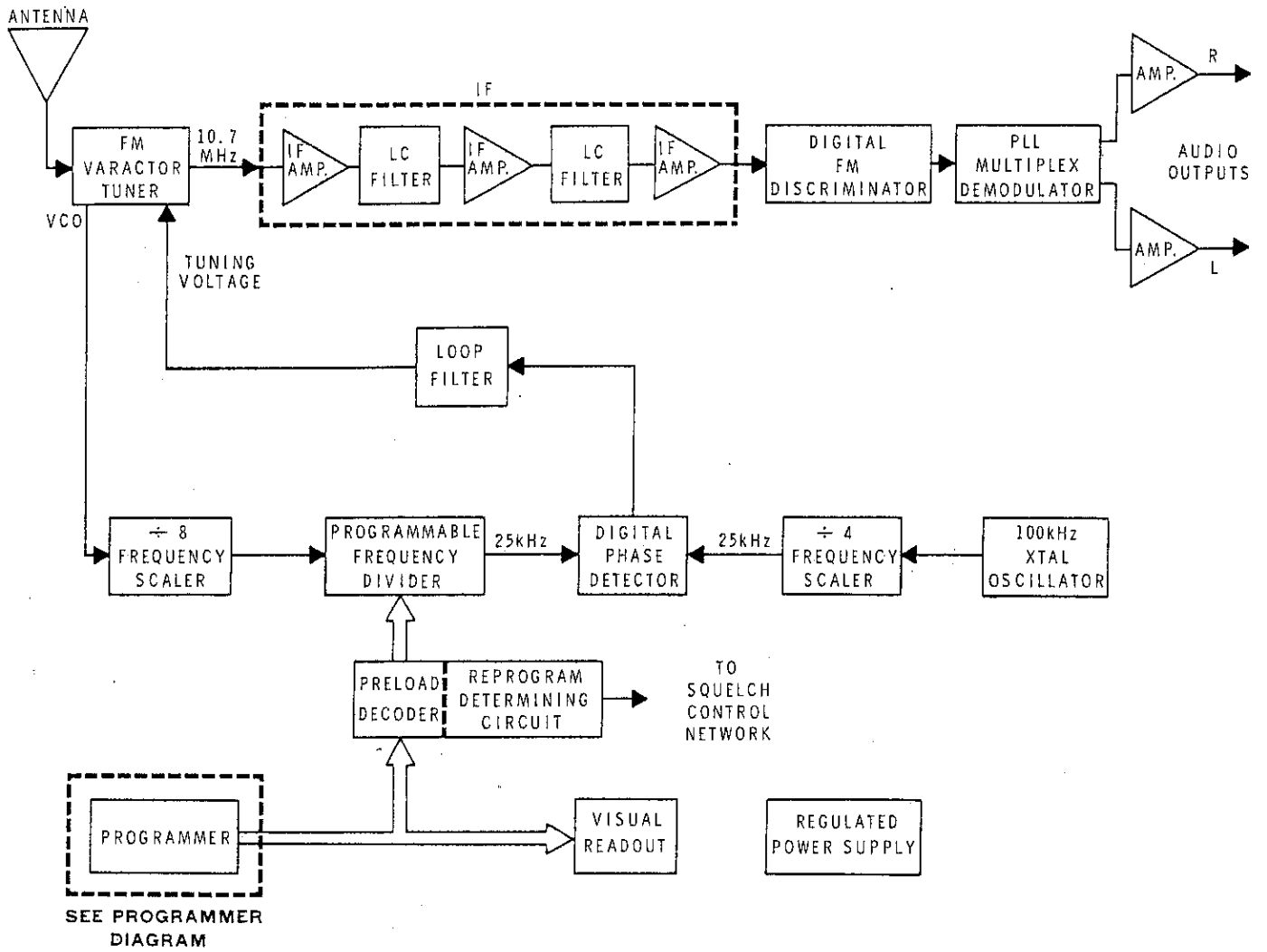

BLOCK DIAGRAM

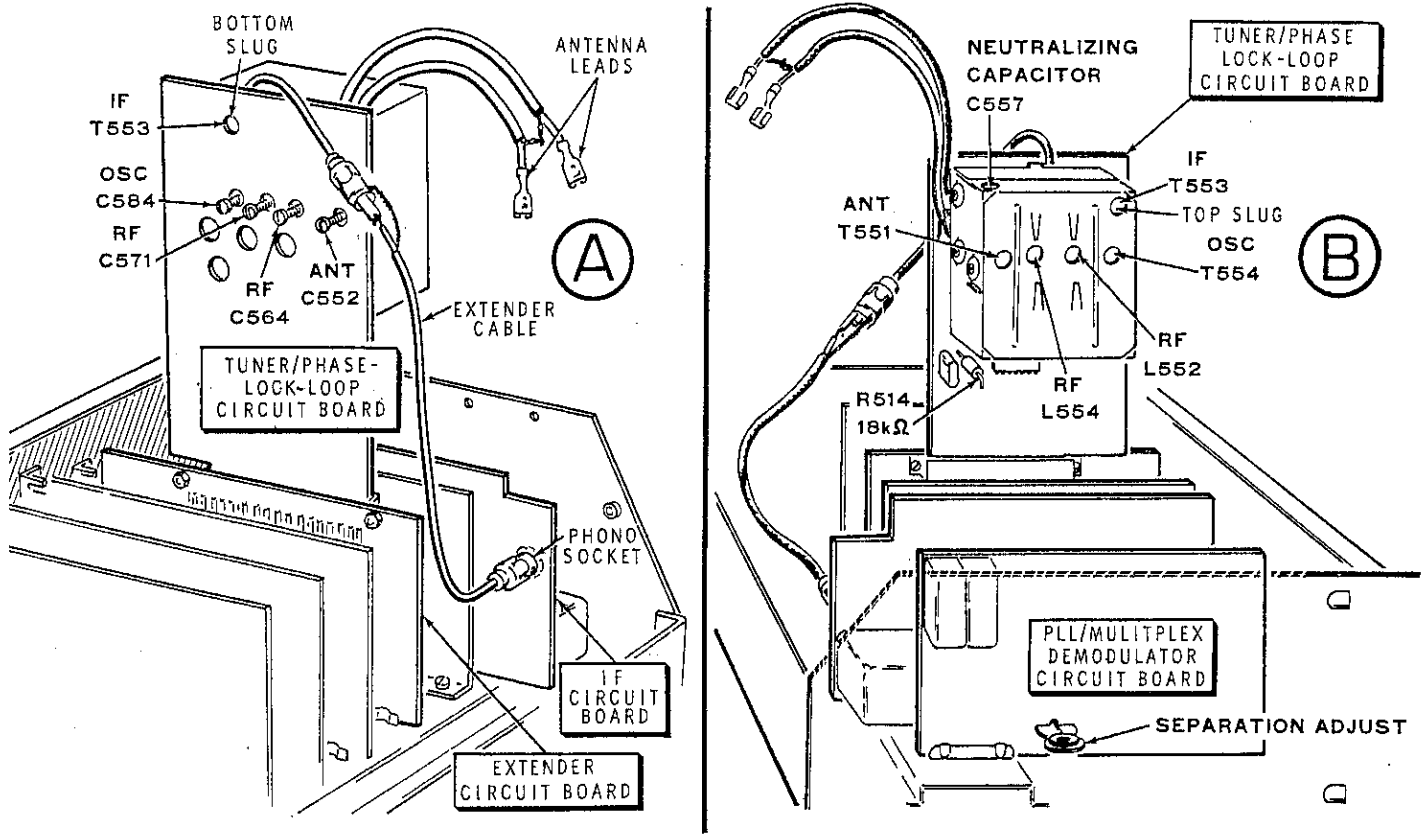
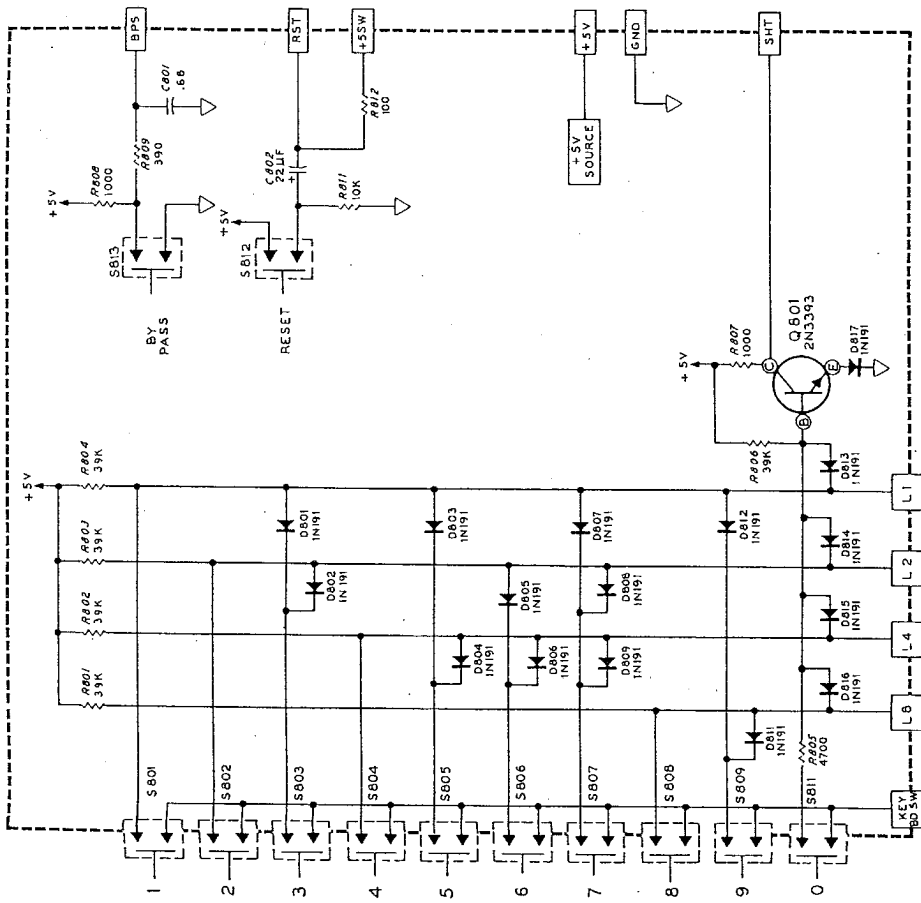

Figure 5-4



KEYBOARD CIRCUIT BOARD

COMPONENT NUMBER	HEATH PART NUMBER	MAY BE REPLACED BY	DESCRIPTION	LEAD CONFIGURATION
Q801	417-118	2N33393	NPN TRANSISTOR	
D801-D809 D811-D817	56-26	1N191	CRYSTAL DIODE 90V, 45mA	

SEMICONDUCTOR CHART

PROGRAMMER CIRCUIT BOARD

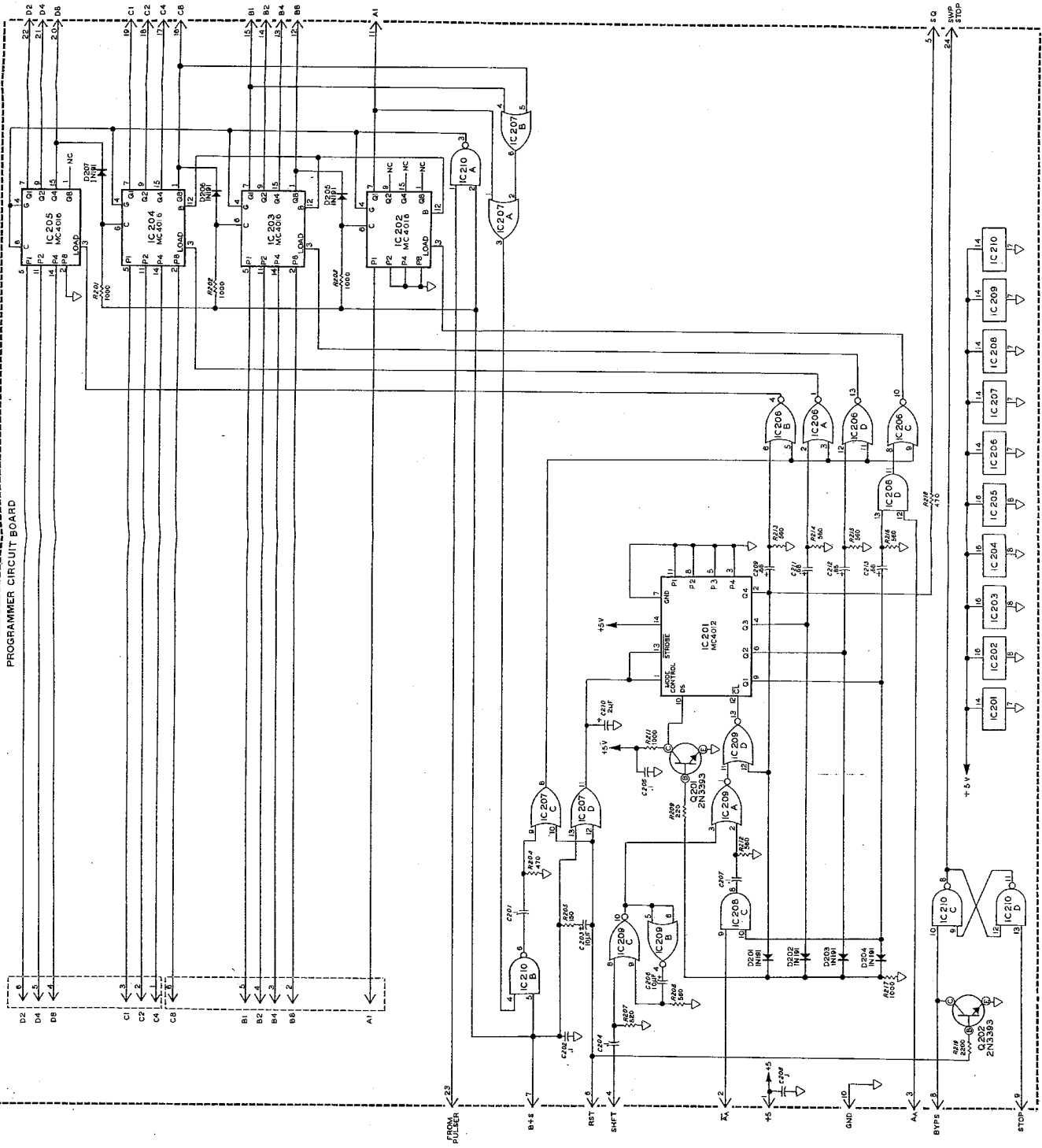

SEMICONDUCTOR CHART

COMPONENT NUMBER	HEAT SINK NUMBER	REPLACES RE	DESCRIPTION	LEAD CONFIGURATION
Q201 Q202	411-118	2N3393	TRIPLE TRANSISTOR	1, 5 (BOTTOM VIEW) OR 1, 5 (TOP VIEW)
IC201-IC203	54-75	1N4151	CN333AL 1N4151 MA	1, 5 (BOTTOM VIEW) OR 1, 5 (TOP VIEW)
IC210	403-1	5N7400N	QUADRUPLE POSITIVE-NAND GATES	(TOP VIEW) VCC 4B 4A 4Y 3B 3A 3Y 1A 1B 1Y 2Y 2A 2B 2Y
IC206 IC209	403-16	5N7402N	QUADRUPLE POSITIVE-NAND GATES	(TOP VIEW) VCC 4B 4A 4Y 3B 3A 3Y 1A 1B 1Y 2Y 2A 2B 2Y
IC208	403-05	5N7408N	QUADRUPLE POSITIVE-NAND GATES	(TOP VIEW) VCC 4B 4A 4Y 3B 3A 3Y 1A 1B 1Y 2Y 2A 2B 2Y
IC200	403-17	MC4001P	QUADRUPLE 2-INPUT POSITIVE-OR GATES	(TOP VIEW) VCC 4B 4A 4Y 3B 3A 3Y 1A 1B 1Y 2Y 2A 2B 2Y
IC203	403-08	MC4001P	4-BIT SHIFT REGISTER	(TOP VIEW) VCC 4B 4A 4Y 3B 3A 3Y 1A 1B 1Y 2Y 2A 2B 2Y
IC204 IC205 IC206 IC207	403-01	MC4001P	PROGRAMMABLE BICOMPUTER	(TOP VIEW) VCC 4B 4A 4Y 3B 3A 3Y 1A 1B 1Y 2Y 2A 2B 2Y

1	0	7	•	10
A ₁	B ₈ B ₄ B ₂ B ₁	C ₈ C ₄ C ₂ C ₁		D ₈ D ₄ D ₂
L	H H H H	H L L L		L H L

Although the 107.(10) is entered into the data multiplexer, the count down signal immediately causes a count down. Thus, the first number to be seen on the readout is 107.9.

DATA MULTIPLEXER

The data multiplexer circuitry, IC5 through IC8, is located on the master circuit board. It directs the BCD information from the three fm station selection inputs to the programmer circuit.

The input AND gates, IC5 through IC8, are internally connected so the inputs assume a positive voltage (H) when they are open circuited. A high output is produced only when all three inputs are open circuited (H) at the same time.

When the Preprogram switch is pressed, the appropriate card reader contacts are connected to ground (L). Only when the preprogrammed card opens the desired card reader contacts does the particular AND gate produce a high output.

The keyboard and auto-sweep inputs to the data multiplexer output NAND gates are both connected to a positive voltage (H) in the preprogram mode. The output from these NAND gates is low only when all three inputs are high at the same time.

Figure 6-3 illustrates how a notch in the preprogrammed card applies a high to the input of the programmer circuit. It shows also how no notch in the card produces a low input.

When the Keyboard switch is pressed, all three card readers are open circuited. The AND gate

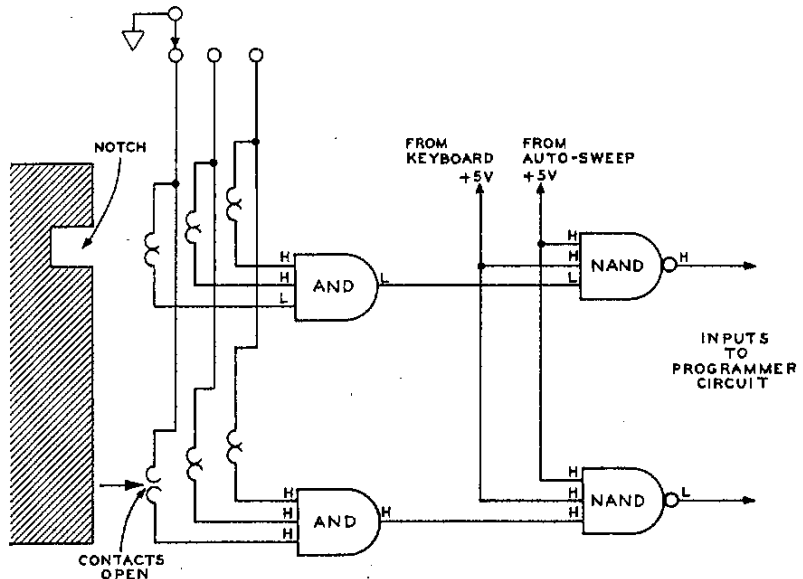

Figure 6-3

outputs are now all high because all of the inputs are open circuited (H). Also, because all NAND gate inputs are H, the inputs to the programmer circuit are L.

As explained previously, when a decimal number key is pressed, the appropriate outputs are grounded (L). A low on the NAND gate inputs causes a high output.

The auto-sweep mode places a low on six NAND gate inputs as explained previously. This low is the BCD equivalent of 107.(10). The programmer circuit input then appears as follows:

1	0	7	(10)
A ₁	B ₈ B ₄ B ₂ B ₁	C ₈ C ₄ C ₂ C ₁	D ₈ D ₄ D ₂
H	L L L L	L H H H	H L H

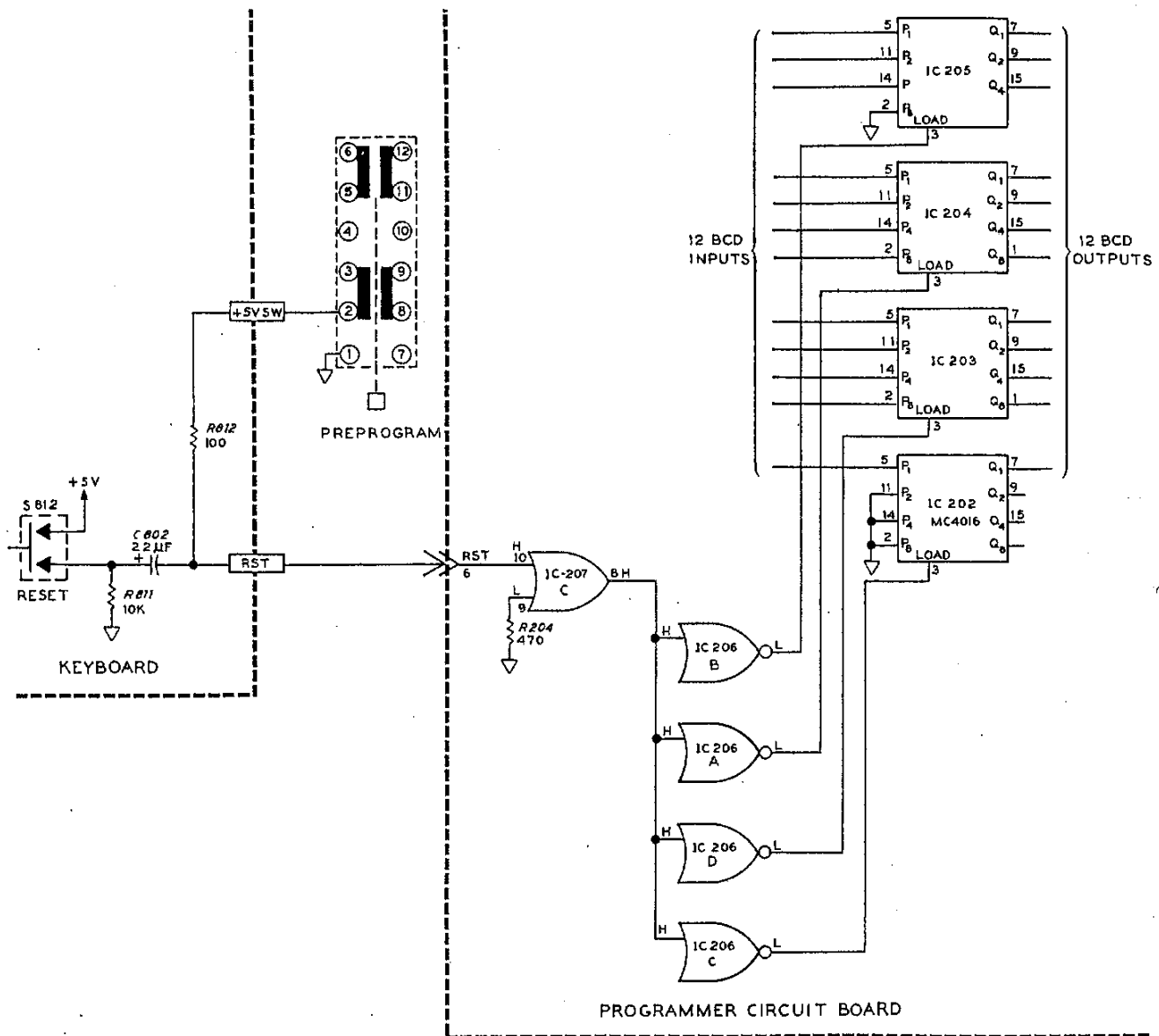

Figure 6-4

PROGRAMMER

PREPROGRAM MODE

The RST (reset) line to the programmer circuit board is normally connected to ground (L) through R812 on the keyboard and the Preprogram switch. In the preprogram mode, however, the RST line is open circuited as shown in Figure 6-4. All of the OR gates of IC207 are internally connected so the inputs assume a high (H) level when they are open circuited. The RST line will then let one input (pin 10) of IC207C assume a high; this results in a high output. A high to one input of each NOR gate (IC206A, IC206B,

IC206C, and IC206D) produces a low output from each gate.

A low to the load inputs of the registers; A, B, C, and D (IC202, IC203, IC204, and IC205); allows the BCD station information present on the twelve input lines to enter the registers. Since the register load lines are always low whenever the preprogram mode is selected, the BCD station information on the preprogrammed card appears at the twelve register outputs.

KEYBOARD MODE

In the keyboard mode, a register will not accept an input unless its load line is low. Also, since the BCD information from the keyboard can represent only one number at a time, it is necessary to direct this information to the proper register. A shift register (IC201) is used for this purpose.

Initially the outputs (Q1, Q2, Q3, and Q4) of shift register IC201 are low. This permits the NOR gate circuit, diodes D201 through D204 and transistor Q201, to place a high at the serial input (DS) of the shift register. A shift pulse applied to the shift right input (\overline{CL}) shifts the high from the DS input to the Q1 output. As soon as one of the Q outputs is high, the NOR gate circuit (D201 through D204 and Q201) removes the high from the DS input and holds it low. It will remain low until all the shift register outputs are again low. A second shift pulse shifts the high from the Q1 to the Q2 output, leaving Q1 low. A third shift pulse shifts the high from the Q2 to the Q3 output, leaving Q2 low. A fourth shift pulse shifts the high from the Q3 to the Q4 output, leaving Q3 low.

As previously explained, a positive shift signal is produced by the keyboard whenever one of the keyboard output lines is low. This positive shift signal is coupled through capacitor C204 to NOR gate IC209C. NOR gates IC209C and IC209B form a one-shot multivibrator circuit. This circuit, in effect, holds the shift pulse for a short period of time (10 milliseconds) and blocks any switch bounce pulses that may have occurred. The output from IC209C is coupled through NOR gates IC209A and IC209D to the shift right input (\overline{CL}) of shift register IC201.

Normally, the inputs (keyboard outputs L_2 , L_4 , and L_8) to NAND gate IC1B are high. This makes the output of IC1B ($\overline{A_A}$) low. (IC1B is located on the master circuit board.) Whenever keyboard keys 2 through 9 are pressed, at least one of these keyboard outputs will be low. A low at any of the NAND gate inputs will cause a high at $\overline{A_A}$.

Transistor Q1 functions as an inverter. The output of Q1 (A_A) is always opposite $\overline{A_A}$. When $\overline{A_A}$ is high, A_A is low.

The first number entered on the keyboard will initiate the first shift signal. A shift right will occur within the shift register and place a high at the Q1 output. This high is coupled through capacitor C213 to AND gate IC208D. If the first number is either a 1 or 0, the A_A input will be high. A high input at both inputs of AND gate IC208D will produce a high output. A high input to NOR gate IC206C will produce a low output. Now that the register A load line is low, the BCD information (1 or 0) on the A_1 input line is loaded into register A.

However, if the first number entered on the keyboard was other than a 1 or 0, the A_A input is low. A low at either AND gate (IC208D) input will place a low on the input of NOR gate IC206C. This prevents register A from loading. But now, both output Q_1 and $\overline{A_A}$ are high. Anytime these inputs to AND gate IC208C are high, a second shift pulse is produced at the output. This second shift pulse places the Q_2 output of IC201 high and this high is coupled through capacitor C212 to NOR gate IC206D. The output of IC206D, now low, also places the register B load line low. Thus, if the first number entered is other than 1 or 0, it will be placed in register B.

As the last number is entered, the Q_4 output of shift register IC201 goes high. This high is applied to one input of NOR gate IC209D to prevent additional shift pulses from reaching the shift right (\overline{CL}) input of IC201.

Pressing the Reset key applies a high through capacitor C802 (on the keyboard) to the inputs of IC207D and IC207C. OR gate IC207D places a high to the MODE CONTROL and STROBE inputs of IC201 and clears the shift register so all Q outputs are low. IC207C also places a high at one input of each NOR gate of IC206. The load lines to registers A, B, C, and D are low and allow the lows (zeros) present on all input lines to enter the registers.

During the keyboard loading process, the audio signals are squelched. The signal at the Q_4 output of the shift register is also present at the squelch output (SQ). When Q_4 is low, which occurs during keyboard loading, the audio signal is squelched. After the last number has been entered, the Q_4 output is high. This high at the SQ output allows the squelch circuits to function normally.

AUTOMATIC SWEEP MODE

In the automatic sweep mode, registers A, B, C, and D are used to count down. These registers are first loaded with the BCD equivalent of 107. (10); then a pulse signal is applied to make them count down. When the count reaches the BCD equivalent of 87.9, a reset occurs, reloading the 107. (10) into the registers.

Pressing the Auto-Sweep switch applies the BCD equivalent of 107. (10) to the input lines of register A, B, C, and D. It also places +5 volts (H) on the B+S line. This high is coupled through resistor R205 and capacitor C203 to the RST (reset) line. A high to the input of OR gate IC207C also places a high on the inputs to the NOR gates (A, B, C, and D) of IC206. All of the outputs of IC206 are momentarily low; this allows the registers to load the 107. (10) information present on the input lines.

The Auto-Sweep switch also connects +5 volts to the +5V SW line of the generator-divider-oscillator circuit board. This voltage is the power for IC408. An astable multivibrator circuit, IC408C and IC408B, applies a pulse to a squaring circuit, IC408A and IC408D. The frequency of this pulse generator is adjustable by control R51 from approximately 1 to 10 pulses per second. This signal is used in the automatic sweep mode to pulse the count down register. An input (sweep stop) that is used to stop the pulse generator will be explained later.

The pulse generator signal serves two functions. First, it pulses the clock (C) input of the first down counter (register D) to cause it to count down. Second, it is used to synchronize the load signal.

Registers A, B, and C count down (9, 8, 7, 6, 5, 4, 3, 2, 1, 0, 9, 8, etc.) one number at a time. A count down occurs each time the clock input goes from a low to a high level. This clock pulse is formed by the output of the preceding register.

Unlike the other registers, when register D counts to zero it internally produces a reload signal. The BCD information ($D_8 = H$, $D_4 = L$, $D_2 = H$) present at the input is reloaded into the register when the pulse generator signal goes low. When the signal returns high, the register counts down to 4. The reload and first count down happens very quickly due

to the short duration (approximately 40 to 70 μsec) of the pulses. Each time the register reloads, the low to high (0 to +5V) transition at output Q4 is coupled to the clock input of register C; this causes it to count down one number.

NAND gates IC210C and IC210D form an R-S type flip-flop. When the set input (pin 13 of IC210D) goes low, the flip-flop sets so the output is also low. When the reset input (pin 10 IC210C) goes low, the flip-flop output resets so the output is high.

The squelch circuit which will be explained later, supplies a STOP signal to the set input of the flip-flop. A STOP signal (low), applied to the R-S flip-flop, produces an SWP STOP output signal (low) which stops the pulse generator circuit. This, in turn, causes the automatic sweep count down to also stop. The flip-flop will remain in its set condition even if the STOP signal goes high.

The reset input (pin 10 of IC210C) is connected to +5 volts (high) through resistors R809 and R808 on the keyboard circuit board. The Bypass keyboard key resets the flip-flop by placing the reset input to ground (low). When the flip-flop resets, the output (SWP STOP) goes high, the pulse generator restarts, and the count down of the register continues.

READOUT CIRCUIT BOARD

The readout circuit consists of four numerical display tubes and three BCD-to-seven-segment decoder driver integrated circuits. Tubes V902, V903, and V904 are similar seven-segment display tubes with the exception of the decimal point in V904. Tube V901 is a two segment tube that can only display the numeral 1. The numerals of each tube are lighted by grounding the appropriate segments.

Integrated circuits IC901, IC902, and IC903 decode the BCD (binary coded decimal) information from the twelve output lines of the programmer circuit board. The D₁ input (pin 7) of IC903 is always tied to a high (+5V). This allows only the odd numerals of V904 to light.

Decimal point input (pin 5) of IC903, which is connected to +5 volts (high), holds the output (pin 4) grounded (low).

This ensures that the decimal point in display tube V904 is always lit.

The segments of display tube V901 are connected to the decimal point outputs (pin 4) of IC901 and IC902. Whenever the decimal point inputs (pin 5) of IC901 and IC902 are high, both segments of V901 are grounded and light the numeral 1. Since the decimal point inputs are both connected to input A₁, the numeral 1 of tube V901 is lit whenever A₁ is high.

When the L/T (light test) switch S57 is pressed, the L/T inputs (pin 3) to IC901, IC902, and IC903 are grounded. This causes all outputs of each integrated circuit to go low and light all the display tube segments.

Transistor Q901 is the reprogram lamp driver and is discussed in the description of the preload decoder circuit.

PRELOAD DECODER CIRCUIT BOARD

The logic circuitry located on the preload decoder circuit board receives the BCD (binary coded decimal) station information and converts it to another binary number. This new binary number is used to load the programmable divider circuit. Logic redundancies eliminate the need for binary inputs beyond B_1 ; this simplifies the logic circuitry. Also, because the P_{B4} output is always high, it is not required.

The following chart shows each fm station frequency and the corresponding preload decoder output.

Station Frequency (MHz)	Preload Decoder Output	Station Frequency (MHz)	Preload Decoder Output
88.1	150	95.5	187
88.3	151	95.7	188
88.5	152	95.9	189
88.7	153	96.1	190
88.9	154	96.3	191
89.1	155	96.5	192
89.3	156	96.7	193
89.5	157	96.9	194
89.7	158	97.1	195
89.9	159	97.3	196
90.1	160	97.5	197
90.3	161	97.7	198
90.5	162	97.9	199
90.7	163	98.1	200
90.9	164	98.3	201
91.1	165	98.5	202
91.3	166	98.7	203
91.5	167	98.9	204
91.7	168	99.1	205
91.9	169	99.3	206
92.1	170	99.5	207
92.3	171	99.7	208
92.5	172	99.9	209
92.7	173	100.1	210
92.9	174	100.3	211
93.1	175	100.5	212
93.3	176	100.7	213
93.5	177	100.9	214
93.7	178	101.1	215
93.9	179	101.3	216
94.1	180	101.5	217
94.3	181	101.7	218
94.5	182	101.9	219
94.7	183	102.1	220
94.9	184	102.3	221
95.1	185	102.5	222
95.3	186	102.7	223
		102.9	224
		103.1	225
		103.3	226
		103.5	227
		103.7	228
		103.9	229
		104.1	230
		104.3	231
		104.5	232
		104.7	233
		104.9	234

SEMICONDUCTOR CHART

COMPONENT NUMBER	HEATH PART NUMBER	MAY BE REPLACED BY	DESCRIPTION	LEAD CONFIGURATION
Q901	417-94	2N3416	NPN TRANSISTOR	
IC901 IC902 IC903	443-64	CD2500E	BCD TO 7-SEGMENT DECODER-DRIVER	

L/T - LIGHT TEST
 DP0 - DECIMAL POINT OUTPUT
 DP1 - DECIMAL POINT INPUT
 A B C D BCD INPUTS

READOUT CIRCUIT BOARD

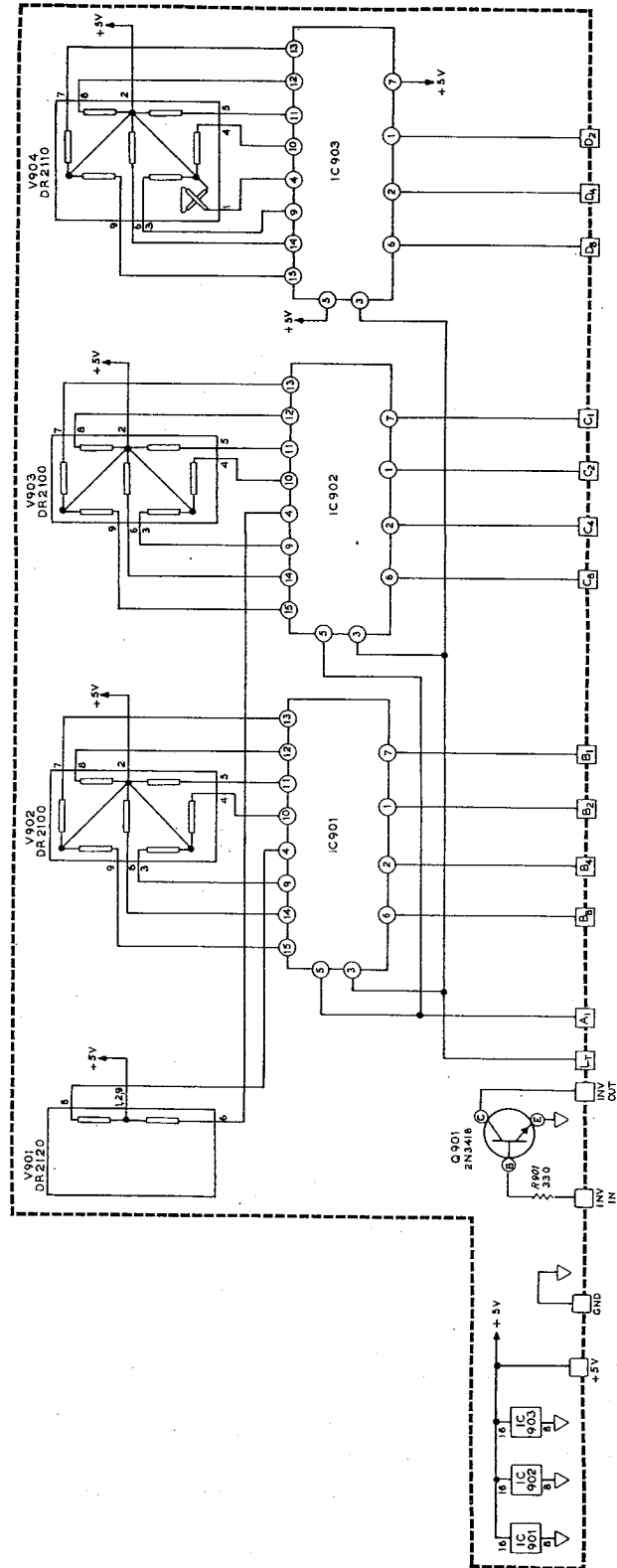

SEMICONDUCTOR CHART

COMPONENT NUMBER	HEATH PART NUMBER	MAY BE REPLACED BY	DESCRIPTION	LEAD CONFIGURATION
Q301	417-118	2N3393	NPN TRANSISTOR	BOTTOM VIEW OR TOP VIEW
IC302 IC305 IC308	443-1	SN7400N	QUADRUPLE 2-INPUT POSITIVE NAND GATES	TOP VIEW
IC304 IC309	443-12	SN7410N	TRIPLE 3-INPUT POSITIVE NAND GATES	TOP VIEW
IC303 IC306	443-18	SN7404N	HEX INVERTERS	TOP VIEW
IC310	443-45	SN7408N	QUADRUPLE 2-INPUT POSITIVE AND GATES	TOP VIEW
IC301 IC307	443-698	TTL7486	QUADRUPLE 2-INPUT EXCLUSIVE OR GATES	TOP VIEW

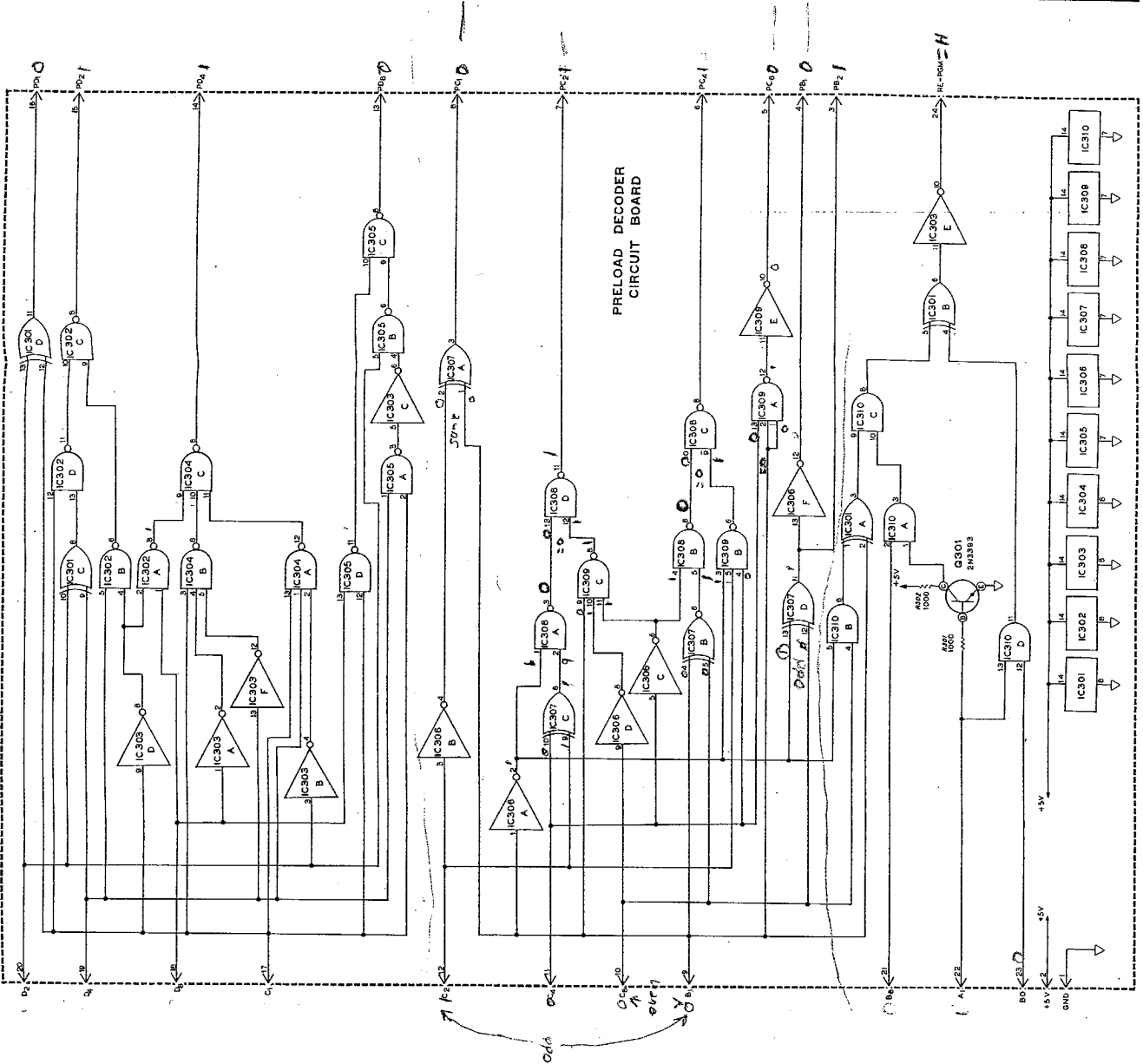

Station Frequency (MHz)	Preload Decoder Output
105.1	235
105.3	236
105.5	237
105.7	238
105.9	239
106.1	240
106.3	241
106.5	242
106.7	243
106.9	244
107.1	245
107.3	246
107.5	247
107.7	248
107.9	249

A reprogram circuit will turn on the Re-program light and squelch the audio signal if the Tuner is programmed outside the fm frequency band (88.1 to 107.9 MHz).

Part of this circuit; IC9A, IC9B, IC9C, IC9D, and Q2; is located on the master circuit board. The four two-input OR gates form the equivalent of a single five-input OR gate. Transistor Q2 is an inverter and makes the entire circuit a five-input NOR gate. The five inputs (B_8 , B_4 , B_2 , B_1 , and C_8) are from the programmer circuit. Only when all of the inputs to this NOR gate are low will the BO' output to the preload decoder be high.

The remaining portion of the reprogram circuit (IC301A, IC301B, IC310A, IC310B, IC310C, IC310D, IC303E, and Q301) is located on the preload decoder circuit board. Inputs to this circuit include BO', A_1 , B_8 , B_1 , C_8 , and \bar{B}_1 . The preload decoder output (RE PGM) is connected to the reprogram squelch circuit on the multiplex circuit board and to an input (INV IN) of the readout circuit board. When this signal is high, it will cause the squelch circuits to squelch the audio signal. Also, transistor Q901 on the readout circuit board functions as a switch and turns on the Reprogram light whenever the reprogram signal is high.

GENERATOR-DIVIDER-OSCILLATOR CIRCUIT BOARD

The generator-divider-oscillator circuit board contains three separate circuits; a pulse generator, a programmable divider, and a 100 kHz oscillator.

PULSE GENERATOR

The pulse generator, an adjustable astable multivibrator, supplies a pulse to the automatic-sweep down counter. This circuit was explained previously in the programmer description on Page 200.

PROGRAMMABLE DIVIDER

The programmable divider consists of three programmable up/down decade counters; IC403, IC404, and IC405; in cascade. A common load line is used to simultaneously reload the counters when a negative going (low) pulse is received from the recycle logic. BCD inputs received from the preload decoder are always present and will not change unless a different fm frequency is selected. Each counter will count down to zero from the loaded count and then function as an ordinary decade counter until the next load pulse. The input (DIV IN) to the programmable divider is the VCO (voltage controlled oscillator) scaler output from the tuner circuit board. (The VCO signal will be explained later on Page 206.) Since this VCO signal causes the counter to count down, it is divided, as determined by the BCD inputs, by the counter.

Due to propagation delay, it is impossible to reload at the end of a count and not lose several pulses. Therefore, a recycle logic circuit is used to "anticipate" the last count. The recycle logic consists of IC406A, IC406B, IC406C, IC407A, IC407B, and IC407C. This circuit senses the BCD output state of each counter. When $B = 0$, $C = 5$, and $D = 7$, the output (pin 6) of NOR gate IC406B goes high. The very next pulse from the VCO scaler (DIV IN) causes the output (pin 8) of NAND gate IC407C to go low. This negative transition reloads the programmable divider to restart the count down sequence again. Thus, the recycle logic is "setup" at count 57, but the actual reload occurs on the next VCO input pulse (count 56).

OSCILLATOR

A highly accurate 100 kHz oscillator is formed by NAND gates IC401A, IC401B, and crystal Y401. NAND gates IC401D and IC401C, connected in an R-S flip-flop configuration, provide a symmetrical square wave output.

J-K flip-flops IC402A and IC402B form a divide-by-four circuit. The 100 kHz signal, when divided, produces a 25 kHz output signal. This 25 kHz signal is used as a reference signal for the phase detector (input X) on the tuner circuit board.

TUNER-PLL CIRCUIT BOARD

FM TUNER

FM broadcast signals (88.1 to 107.9 MHz) are received by the fm tuning unit and converted to an i-f frequency of 10.7 MHz. The tuning unit contains two rf amplifier stages in a cascade configuration, a mixer stage, an oscillator stage, and a buffer stage. FM signals are coupled from an external 300 or 75 ohm fm antenna to the primary winding of transformer T551. The secondary winding is part of a tuned circuit which is tuned to the frequency of the desired station by voltage-variable-capacitance diode D551. The characteristics of this diode are such that it has a certain amount of capacitance. The amount of capacitance is proportional to the dc voltage applied to the diode. The selected signal from this tuned circuit is coupled to the gate of transistor Q551 for amplification. From the drain of Q551, the signal is coupled through capacitor C561 to the drain of transistor Q552 for further amplification. From the source of Q552, the signal is coupled through capacitor C568 to the gate of transistor Q554.

The input signal is also tuned by two resonant circuits composed of voltage-variable-capacitance diode D552 and coil L552, and voltage-variable-capacitance diode D553 and coil L554. The signal is then mixed with the local oscillator signal in transistor Q554 and coupled through transformer T553 to the i-f circuit.

Transistor Q553 operates as a grounded base oscillator. The frequency of this oscillator, which is 10.7 MHz above the incoming rf signal, is determined by the tuning action of coil

T554 and voltage-variable-capacitance diodes D554 and D555. A portion of the oscillator signal is coupled through the secondary winding to the source of transistor Q554. As the oscillator signal and rf signal are mixed, they produce a 10.7 MHz i-f signal which is then coupled through the i-f transformer, T553, to the i-f circuits.

The oscillator signal is also coupled through capacitor C582 to the emitter of transistor Q555 for amplification and isolation. Transistor Q555, a grounded base amplifier, amplifies the oscillator signal to approximately 1.0 volt peak-to-peak. The frequency range of this signal is 98.8 MHz (88.1 + 10.7) to 118.6 MHz (107.9 + 10.7). The output from this circuit, the VCO (voltage controlled oscillator) signal, is divided by the VCO scaler circuit and applied to the programmable divider circuit.

VCO FREQUENCY SCALER

The VCO frequency scaler is a high speed divide-by-eight circuit made up of three divide-by-two circuits. This circuit divides the 98.8 to 118.6 MHz VCO frequency from the tuner by eight to provide a 12.350 to 14.825 MHz square wave to the programmable divider circuit.

IC501A and IC501B are OR/NOR gates connected in series to form another buffer amplifier. This buffer stage is needed to drive IC502, a high-speed type-D flip-flop, the first divide-by-two circuit. The output of IC502 drives the second divide-by-two circuit, IC503A, a J-K flip-flop. The output of IC503A drives the third divide-by-two circuit, IC503B, also

a J-K flip-flop. The series combination of these three flip-flops provides a frequency scale factor of eight ($VCO \div 2 \div 2 \div 2 = \frac{VCO}{8}$).

The output of IC503B is coupled through capacitor C503 to NAND gate IC504D. NAND gates IC504C and IC504D form an interface between the VCO frequency scaler and the programmable divider circuit previously explained.

PHASE DETECTOR AND LOOP FILTER

The phase detector and loop filter compares the 25 kHz reference signal with the divided VCO signal. When these signals differ in frequency or phase, a tuning voltage is produced and applied through the loop filter to the tuner. As this tuning voltage causes the tuner to change frequency, the VCO output and, in turn, programmable divider output also change accordingly until the phase detector output returns to zero.

The phase and frequency detector #1 of IC505A compares the X input (programmable divider output) to the Y input (25 kHz reference). If the X input is lower in frequency (lags in phase) than the reference signal at input Y, the output at pin 13 goes low. When the X input is higher in frequency (leads in phase) than the reference signal at input Y, the output at pin 2 goes low.

A charge pump, IC505B, changes the phase detector outputs to fixed amplitude positive (or negative) pulses. These pulses are applied to an integrator (R505, R506, and C505) and

the loop filter circuit (Q501, IC505C, Q502, and Q503). The loop filter provides a dc voltage proportional to the phase error between the X input and the Y input. When tuned to 88.1 MHz, the voltage applied to the tuner by the loop filter is approximately +3.5 volts dc, while at 107.9 MHz, the voltage is approximately +15 volts dc.

"UNLOCKED" DETERMINING NETWORK

The phase and frequency detector #2 of IC505A also compares the X input to the Y input for a phase or frequency difference. An R-S type flip-flop, formed by NAND gates IC504A and IC504B, is followed by an integrator (R517, D501, and C508) and a driver transistor, Q504.

When the tuner VCO is phase-locked to the reference oscillator, the R-S flip-flop remains in a steady state in which the output at pin 3 is at a positive voltage level. This positive voltage causes Q504 to conduct, coupling a low voltage level to the squelch circuits. Also, because transistor Q505 is held cut off, the "UNLOCKED" indicator will not light.

However, if the tuner VCO becomes unlocked from the reference oscillator, the R-S flip-flop produces a series of pulses, the first of which will turn Q504 off. This places a positive voltage to the squelch circuits (causing the audio to squelch) and to the base of Q505 and turns Q505 on. Whenever transistor Q505 conducts, the "UNLOCKED" indicator lights.

I-F AMPLIFIER CIRCUIT BOARD

The 10.7 MHz signal is coupled from the tuner to pin 3 of i-f amplifier-limiter IC601. IC601 amplifies the signal and provides the proper impedance matching between the tuner and LC filter F601. The LC filter provides selectivity for the i-f signals and exceptional phase linearity for optimum multiplex performance.

The signal is coupled from pins 3 and 4 of filter F601 to the inputs of amplifier IC602. This i-f amplifier has very high gain, extremely good limiting qualities, and a low output impedance. LC filter F602 is identical to filter F601. The signal is coupled from pins 3 and 4 of filter F602 to the inputs of amplifier IC603. In addition to serving as a high gain amplifier, IC603 also drives the digital detector circuit, IC604.

The digital detector circuit contains a retriggerable monostable multivibrator (IC604) and two integrator circuits R609, R612, and C610; and R611, R613, and C640). A pulse at the input (pin 1) of IC604 will cause it to change states for a fixed period of time. The amount of time is determined by the values of capacitor C636 and resistor R608. This provides an output pulse of a constant width and amplitude each time the multivibrator is triggered and rests. Because pin 2 (B2) is connected to pin 6 (\bar{Q}), the multivibrator will only trigger on every other output pulse from amplifier IC603.

An integrator at each output of IC604 produces a voltage directly proportional to the spaces between the output pulses of the multivibrator. The integrator thus produces an audio signal from the frequency modulated signal. Since the multivibrator output signals are out of phase, the integrator output signals are also out of phase.

Operational amplifier IC605 amplifies the integrator output signal. Because these signals are out of phase and applied to the + and - amplifier inputs, they will be added together or summed before they are amplified. Any in-phase signals caused by noise, appearing at both the + and - inputs of IC605, will subtract or cancel. This provides a good signal to noise ratio. The composite output signal from IC605 is coupled to the multiplex demodulator circuits.

I-F amplifier IC603 also contains a quadrature circuit that produces a dc voltage at pin 1 if the received i-f signal is not in the center of the bandpass. During the auto-sweep mode, this deviation circuit overrides the agc (automatic gain control) signal until the received signal is at the center of the bandpass. Once the signal is at center frequency, and providing there is sufficient agc level, the sweep-stop and squelch circuits will stop the sweep and unsquelch the audio signal. Coil L602 is adjusted during the tests so the output of the amplifier is zero volts when the i-f circuit is at center frequency. Amplifier IC603 and transistors Q605, Q606, Q607, and Q601 amplify the deviation signal and couple it to the squelch and sweep-stop circuits on the multiplex demodulator circuit board.

SEMICONDUCTOR CHART

COMPONENT NUMBER	HEATH PART NUMBER	MAY BE REPLACED BY	DESCRIPTION	LEAD CONFIGURATION
Q501 Q502 Q504	417-118	2N3393	NPN TRANSISTOR	
Q505	417-94	2N3416	NPN TRANSISTOR	
Q503	417-201	X29A829	PNP TRANSISTOR	
D501 D502	56-26	1N191	CRYSTAL DIODE 90V, 45mA	
IC504	443-1	SN7400N	QUADRUPL E 4-INPUT NAND GATES	
IC501	443-38	MC1023P	DUAL 4-INPUT OR/NOR GATES	
IC502	443-39	MC1034P	TYPE D FLIP-FLOP	
IC503	443-56	MC1032	DUAL J-K FLIP-FLOP	
IC505	443-62	MC4044P	PHASE/ FREQUENCY DETECTOR	

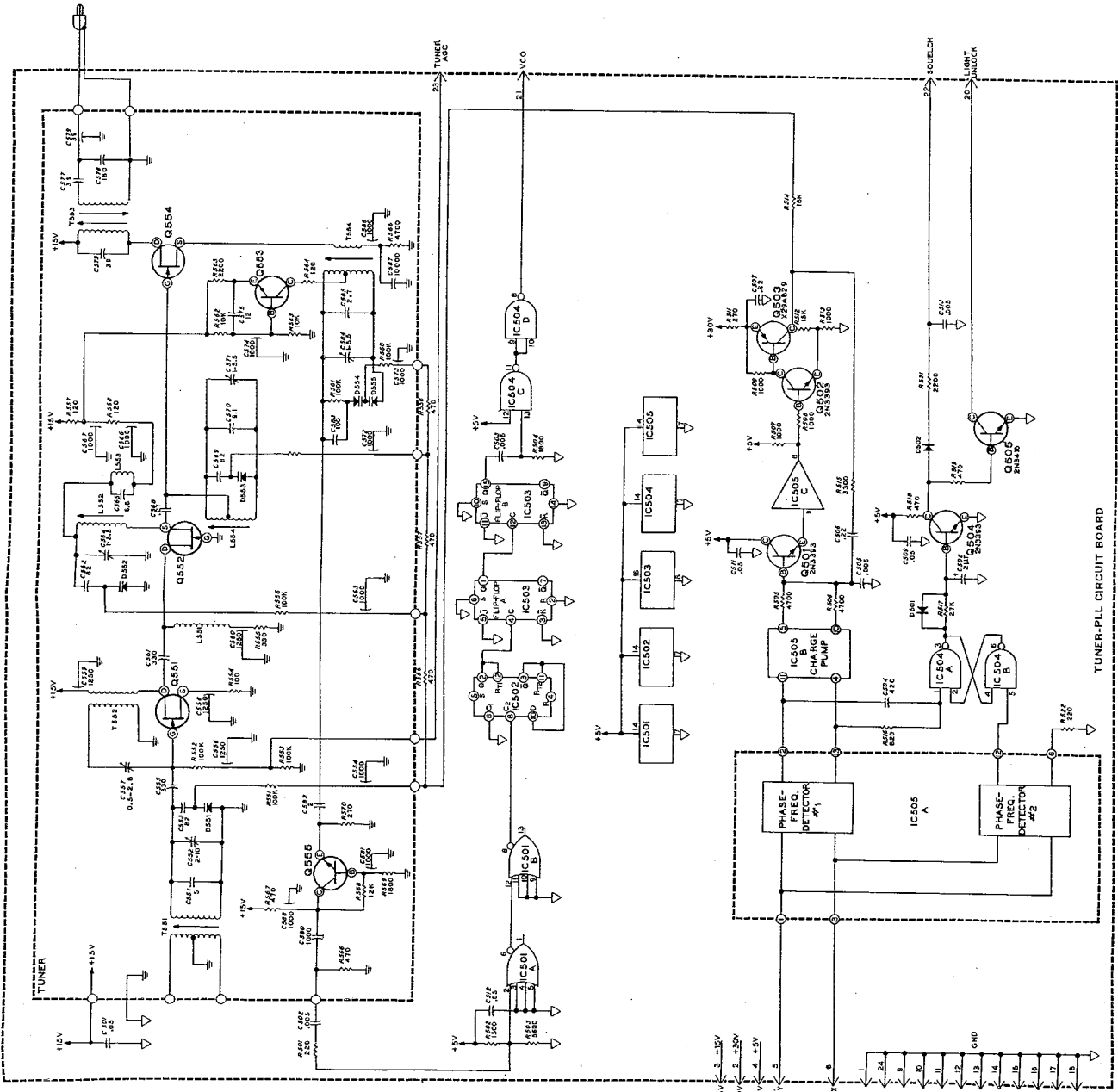

TUNER-PLL CIRCUIT BOARD

SEMICONDUCTOR CHART

COMPONENT NUMBER	PART NUMBER	MAY BE REPLACED BY	DESCRIPTION	LEAD CONFIGURATION
Q602, Q603, Q604	417-118	2N3393	NPN TRANSISTOR	
Q601	417-222	2N5208	PNP TRANSISTOR	
Q605, Q606	417-91	2N3391	NPN TRANSISTOR	
Q607	417-201	X29AB29	PNP TRANSISTOR	
D601 - D609	56-26	1N191	CRYSTAL DIODE	
D611	56-59	1N150A	ZENER DIODE 4.7V, 20mA	
D614	56-74	M22382	DIODE	
IC605	442-2	SN72709	OPERATIONAL AMPLIFIER	
IC607	442-1B	MC1350P	IF AMPLIFIER	
IC601	442-20	HA703	RF-IF AMPLIFIER	
IC602	442-28	MC1357P	FM DETECTOR AND LIMITER	
IC604	443-67	MC8601P	RETUNABLE MONOSTABLE MULTIVIBRATOR	

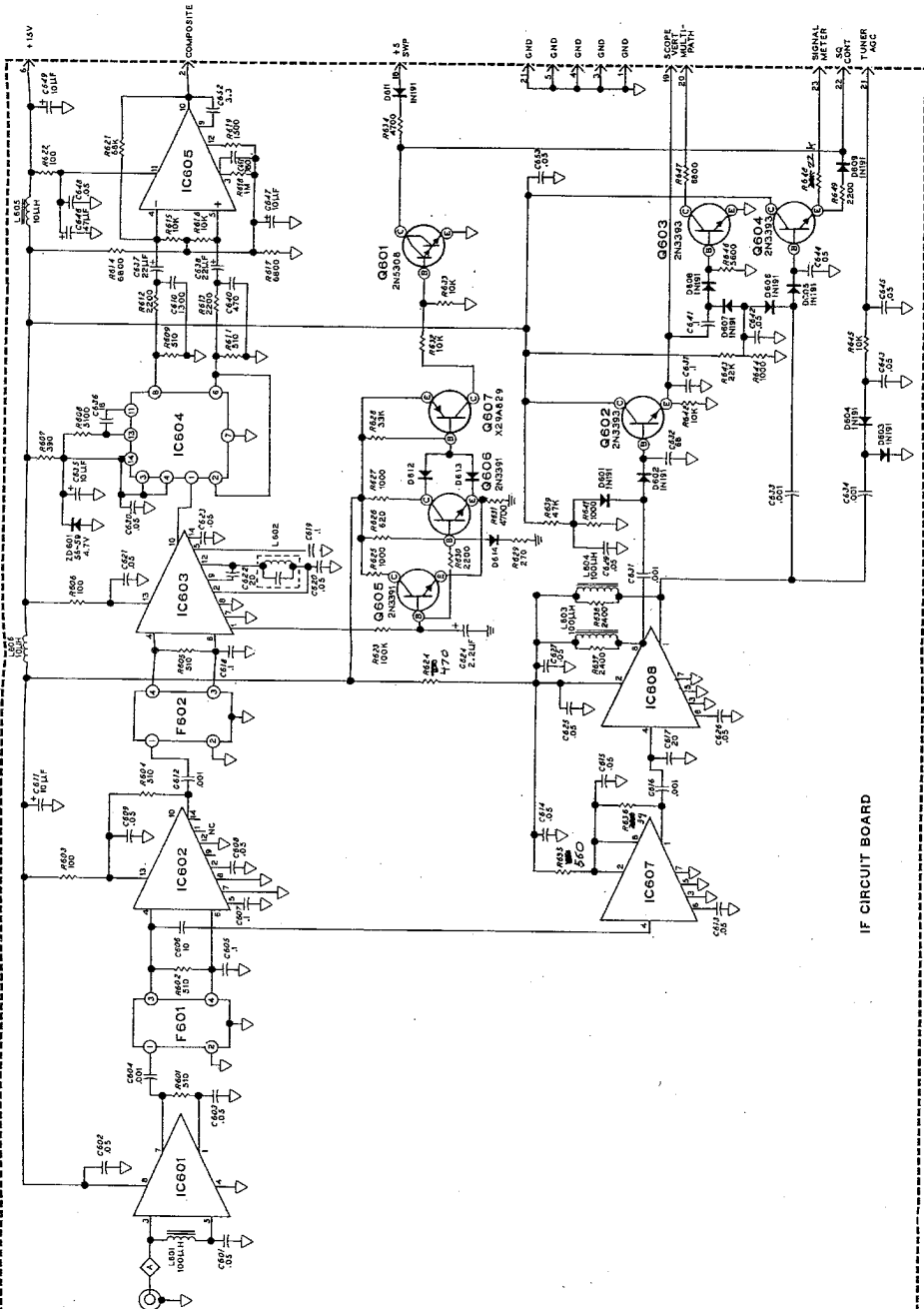

IF CIRCUIT BOARD

Part of the 10.7 MHz i-f signal at the output of LC filter F601 is coupled through C606 to first agc amplifier IC607. The output of IC607 is coupled to the input of the second agc amplifier, IC608. Again the signal is amplified and coupled from the output, pin 1, of IC608 through C634 to rectifier diodes D603 and D604. After being rectified, the dc voltage is filtered by capacitor C643, resistor R634, and capacitor C645 and then coupled to the fm tuner to control the gain of transistor Q551.

AGC (automatic gain control) voltage is proportional to the strength of a received signal and is applied to the gate of Q551 in the fm tuner. Therefore, as stronger station signals are received, more agc voltage is applied to the gate of Q551. Since increased agc voltage reduces the amplification of Q551, overloading and distortion is prevented on strong signals.

The amplified agc signal from IC608 is also coupled through C633 and applied to a voltage doubler circuit (peak-to-peak detector), D606 and D605, before it reaches transistor Q604. The output signal from Q604 is a representation of amplitude variations of the received signal. From the emitter of Q604, this signal is coupled through R649 and D609 to

the squelch and sweep-stop circuits on the multiplex circuit board. Also, this signal is coupled through resistor R648 to the meter. The meter then provides a relative indication of signal strength.

The agc output from pin 8 of IC608 is coupled through capacitor C631 to a voltage doubler (peak-to-peak detector) circuit consisting of diodes D601 and D602. These diodes are biased on by a divider network, R639 and R641, so the slightest rf signal at the input will cause a positive voltage at the output of emitter follower Q602. This output voltage, which is applied to the SCOPE VERT connector, is a representation of amplitude variations of the received signal. The scope vertical is used in conjunction with the composite (scope horizontal) signal as inputs to an oscilloscope multipath indicator.

Another doubler circuit (peak-to-peak detector) is formed by diodes D607 and D608. This circuit further detects the amplitude variations and applies a dc voltage to the meter; this gives an indication of multipath conditions.

MULTIPLEX CIRCUIT BOARD

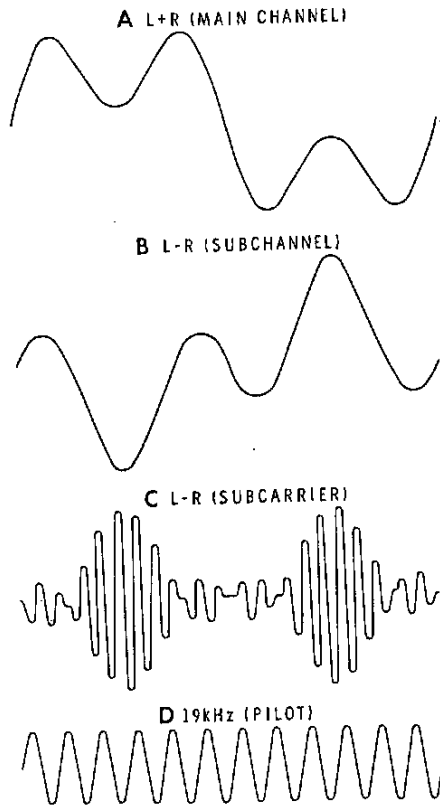

Figure 6-5

MULTIPLEX DEMODULATOR

Left and right channel signals are produced by a radio station that is broadcasting fm stereo. The transmitting circuits then combine these signals to produce the L + R (main channel) signal shown in Figure 6-5A and the L - R (subchannel) signal shown in Figure 6-5B. Note that the L - R signal is superimposed on a 38 kHz signal as shown in Figure 6-5C. This amplitude-modulated L - R signal is transmitted as the subcarrier channel.

The L + R (main channel) signal and the L - R (subcarrier) signal are combined with the 19 kHz pilot signal shown in Figure 6-5D, and the whole complex signal modulates the transmitted rf carrier.

A second subcarrier signal is transmitted by some stations at a frequency of 67 kHz. This channel, which is modulated by a commercial music signal, is called SCA (Subsidiary Communications Authorization) channel.

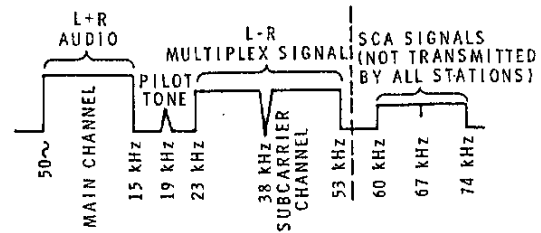

Figure 6-6

Figure 6-6 shows the different components in a commercial stereo fm signal. The L + R signal, which is in the audio spectrum (50 Hz to 15 kHz), is called the "main channel." Monophonic fm tuners use only this part of the signal, and the remaining signal components are attenuated by a de-emphasis network.

For simplification, the internal operation of the phase-locked-loop, multiplex demodulator integrated circuit (IC701) will not be discussed in detail. However, its functional relationship with associated circuitry will be discussed.

IC701 completely demodulates the complex stereo signal, capacitively coupled to pin 2, into its proper left and right channel audio signals which appear at pins 4 and 5 respectively. This integrated circuit has the ability to cancel the ultrasonic components (SCA) that would otherwise be present at the audio output. Previously, elaborate filters had to be designed to accomplish this, sacrificing high frequency audio separation in the Tuner.

The voltage at pin 6 is connected through switching transistor Q718 to one side of the stereo indicator lamp whenever a 19 kHz stereo pilot tone is present. The other side of the stereo indicator lamp is connected to the squelch circuit which will be explained later.

A 19 kHz circuit within IC701 functions as an inductorless filter. This is a phase-locked-loop circuit in which an internal oscillator is phase locked to the incoming 19 kHz pilot tone. Capacitor C705 and resistors R705 and R706 determine the frequency of the oscillator. Resistor R706 is adjusted to fine tune the oscillator for optimum phase-lock performance, for greatest stereo separation, and for minimum audio distortion. The remaining components associated with IC701 set the bandwidth and 19 kHz acquisition range.

The right and left channel amplifiers (Q701, Q703 and Q702, Q704) are direct coupled and apply the detected audio signals through R721 and R722 to LC filters L704 and L705. These filters remove all unwanted signals above 15 kHz that may still be present on the audio signals. The outputs of filters L704 and L705 are coupled through diode switches D701 and D702 and capacitors C712 and C711 to emitter followers Q708 and Q707.

Diodes D701 and D702 are part of the audio squelch circuit and are either saturated or cut off, depending on the state of the squelch driver Q711. Diode D703 is also part of the squelch matrix, but is always at a state opposite that of diodes D701 and D702. The emitter follower output provides a low impedance output to an external amplifier.

NOISE CIRCUIT

Transistors Q712, Q713, and Q714 form a noise amplifier circuit. This circuit applies a signal to the squelch circuits that causes the audio to squelch (turn off) whenever noise is present. Resistor R704 and the Noise Squelch control, R54, provide a variable divider input to the amplifier. Coil L706 and capacitor C721 form a circuit that is tuned to approximately 100 kHz. When noise is present, it will have a 100 kHz component that can be used as an indication of signal quality.

Transistors Q712 and Q713 amplify the 100 kHz noise signal before it is rectified by diodes D711 and D712. Resistor R746 and capacitor C726 form a delay circuit that simply prevents random noise pulses from triggering the squelch circuits. Q714 further amplifies the dc signal and applies it through D713 and D714 to NAND gate IC702A.

SQUELCH CIRCUIT

The function of the squelch control circuit is to accept inputs from various sources within the Tuner and determine from these inputs the state of the audio squelch control voltage (audio on or audio off). These various inputs are themselves determined by the operational state of the entire Tuner. In the automatic sweep mode, the squelch control circuit also delivers a "stop" signal to the auto-sweep circuit. Figure 6-7 shows the overall squelch circuit.

The main logic element of the squelch circuit is the 4-input NAND gate, IC702A. The output (pin 6) of this gate will remain high until all the inputs are simultaneously high. When this occurs, the output switches to a low. Should any or all of the inputs become low, the output will immediately become high. The output of IC702A is coupled through delay network D715, R756, and C723 to emitter follower transistor Q715.

Transistor Q715 drives three circuits; the sweep-stop circuit, the stereo light control circuit, and the audio squelch circuit.

In the auto-sweep mode, the signal at the emitter of Q715 is coupled to the sweep-stop flip-flop (IC210C and IC210D) on the programmer circuit board. When all of the inputs to NAND gate IC702A are high, the output is low. This turns off transistor Q715 and couples a low to the sweep-stop circuit causing the sweep to stop.

Figure 6-8 shows that transistor Q5, which is normally biased to conduct, places one side of the Stereo lamp at +15 volts. Whenever a stereo signal is present, pin 6 of the multiplex decoder IC701 goes low. A low turns on Q718 and the Stereo lamp.

When Q715 is turned on by a positive squelch signal from NAND gate IC702A, a positive signal is also coupled through R758 to transistor Q4. As Q4 conducts, Q5 is turned off removing the +15 volts from the Stereo lamp. This holds the Stereo lamp off whenever a squelch signal is present.

Transistors Q709 and Q711 drive the squelch diode matrix diodes D701, D702, and D703. Besides the squelch inputs from Q715, an input from the unlock determining circuitry on the tuner-PLL circuit board and an input from the reprogram circuitry, are also present. Transistor Q709 is turned on when a positive squelch signal is applied to the base. When Q709 conducts, the cathodes of diode D703 are placed at ground and transistor Q711 is turned off. Transistor Q711, which is normally biased to conduct, removes the ground from the cathodes of diodes D701 and D702. This causes the audio signals to squelch.

The SQUELCH DEFEAT switch S58 places the base of Q709 to ground through resistors R759 and R761. This prevents any of the squelch inputs, with the exception of the reprogram squelch input, from turning off the audio signals. Anytime an incorrect frequency is selected, the reprogram squelch input will override the squelch defeat switch and cause the audio to squelch.

The stereo only switch, S59, normally places the input to NAND gate IC702B at ground. When the stereo only mode is selected, this input is connected through diode D717 to pin 6 of the multiplex decoder, IC701. Resistor R748 now places +5 volts at the input of NAND gate IC702B and produces a low at the output. If a stereo signal is received, pin 6 of IC701 goes low and places a low at the input of IC702B and a high at the output. As explained previously, a high at the output of NAND gate IC702A produces an unsquelch and sweep-stop signal. Thus, the stereo switch allows only stereo signals to be heard and causes the auto-sweep to stop only when a stereo signal is received.

POWER SUPPLY CIRCUIT BOARD

+30 VOLT POWER SUPPLY

Diodes D101, D102, D103, and D104, and capacitors C102 and C107 form a full-wave voltage doubler circuit. Approximately +40 volts will appear across C102 while approximately +20 volts will appear across C107.

Transistor Q101 is a series pass transistor driven by the current through transistor Q102. If the output voltage increases, the voltage of the base of Q103 also increases and causes it to conduct harder. This reduces the current to Q102 which, in turn, reduces the current through Q101. Zener diode ZD101 establishes the reference voltage for the divider.

If the output should become shorted, resistor R103 will limit the current of the power supply. D105 will conduct if the voltage at the base of Q102 exceeds 2.1 volts when a short circuit occurs.

+15 VOLT POWER SUPPLY

Transistor Q104 is a series pass transistor driven by the current through Q105 and Q106. Q105 and Q106, which are connected in a Darlington configuration, are driven by regulator transistor Q107. The voltage across R112 is the reference voltage for the regulator transistor Q107.

+5 VOLT POWER SUPPLY

Diodes D51 and D52 (on the chassis) form a full-wave rectifier that provides between 8 and 10 volts to the regulator. The operation of this regulator is the same as the +15 volt regulator.

RESET

Transistor Q113 is the active part of a turn-on reset circuit. This circuit is used to reset the programmer circuit when power is first applied. When power is first turned on, Q113 conducts and couples a positive pulse to the output. As capacitor C106 charges, the positive output pulse diminishes to zero volts until ac power is turned off and turned on again.

SEMICONDUCTOR CHART

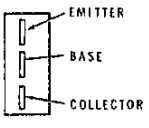
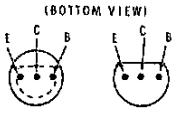
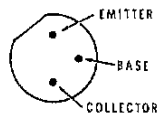
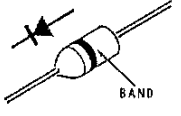
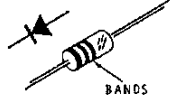
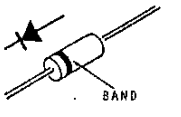
COMPONENT NUMBER	HEATH PART NUMBER	MAY BE REPLACED BY	DESCRIPTION	LEAD CONFIGURATION
Q101, Q104 Q108, Q109	417-175	2N5294	NPN TRANSISTOR	(BOTTOM VIEW) 
Q102, Q103 Q106, Q107 Q111, Q112 Q113	417-118	2N3393	NPN TRANSISTOR	(BOTTOM VIEW) 
Q105	417-110	52090	NPN TRANSISTOR	(BOTTOM VIEW) 
D101, D102 D103, D104	57-27	1N2071	SILICON RECTIFIER 1A, 600V	
D105	56-74	M22362	ZENER DIODE 2.1V, 100mA	
D106	56-26	1N191	CRYSTAL DIODE 90, 45mA	
ZD101	56-47	MZ1000-23	ZENER DIODE 27V, 10mA	

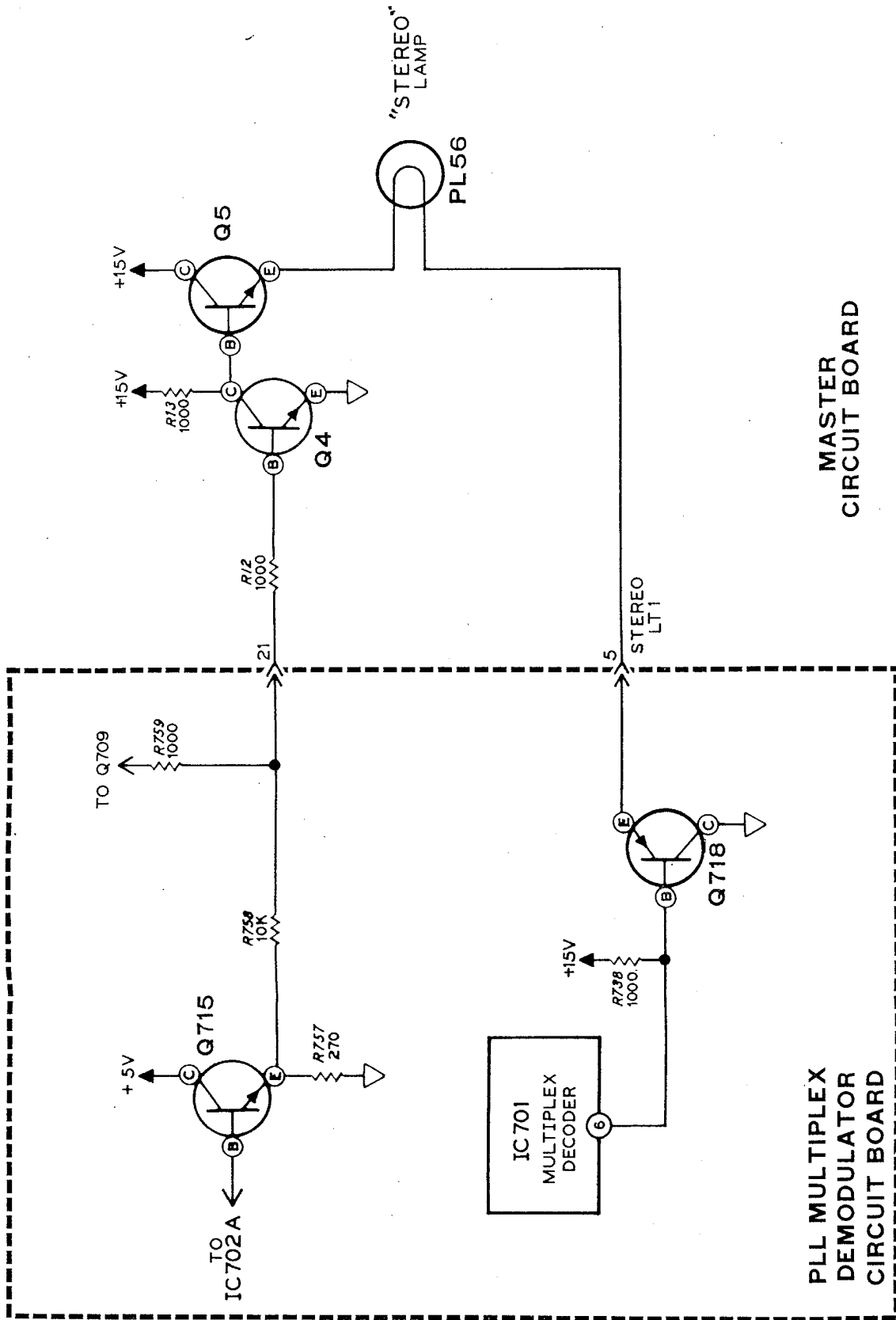
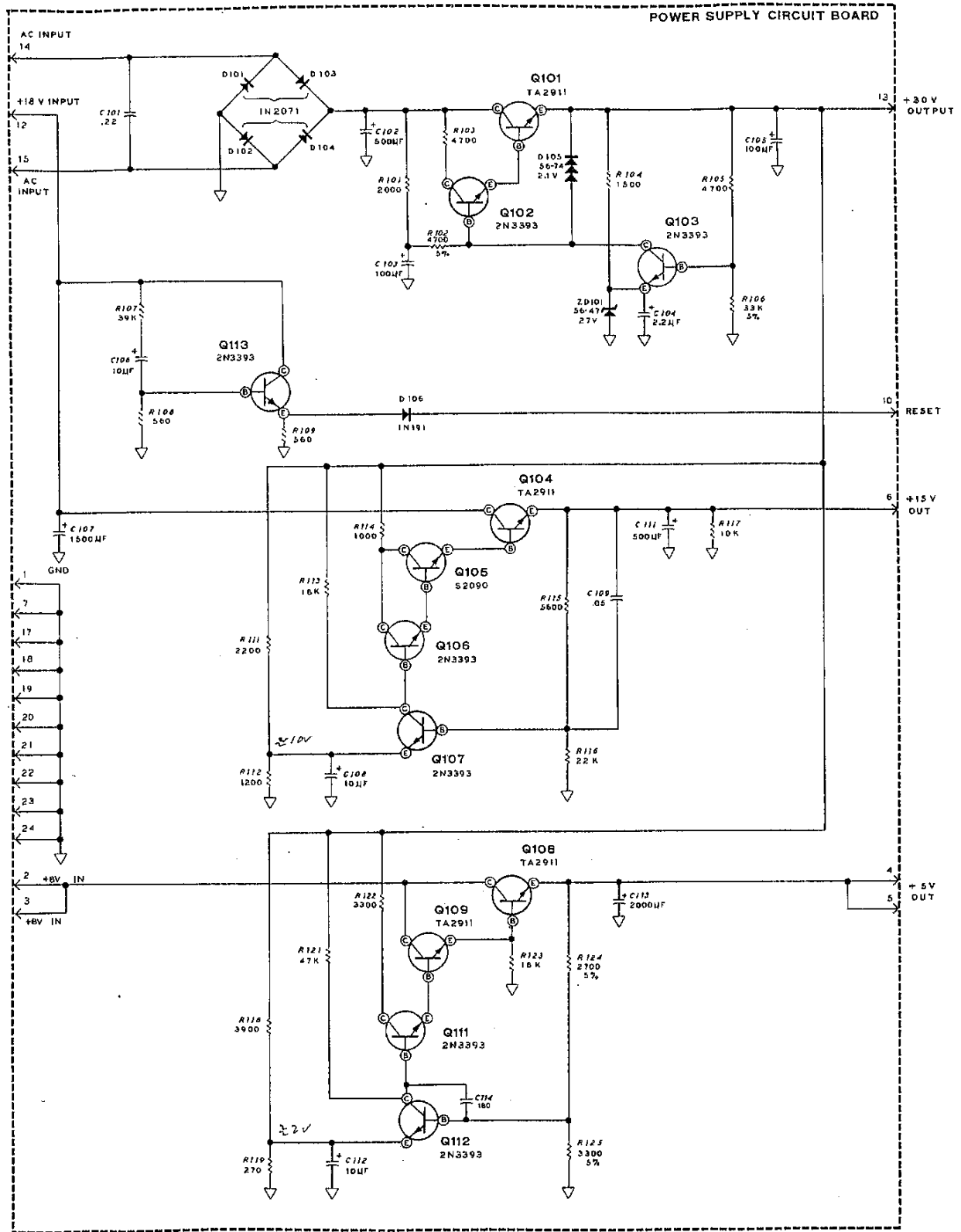

Figure 6-8





CIRCUIT BOARD X-RAY VIEWS

NOTE: To determine the value (22 k Ω , .05 μ F, etc.) of any of these parts, proceed in one of the following ways.

1. For transistors, diodes, and integrated circuits, refer to the "Semiconductor Chart."
2. Refer to the place where the part is installed in the Step-by-Step instructions.

3. Note the identification number of the part (R-number, C-number, etc.). Then locate the same identification number next to the part on the Schematic. The value, or "description," of most parts will be near this number.

Some circuit boards have foil patterns on both sides. The foil pattern on the component side, when two sides are shown, is in RED.

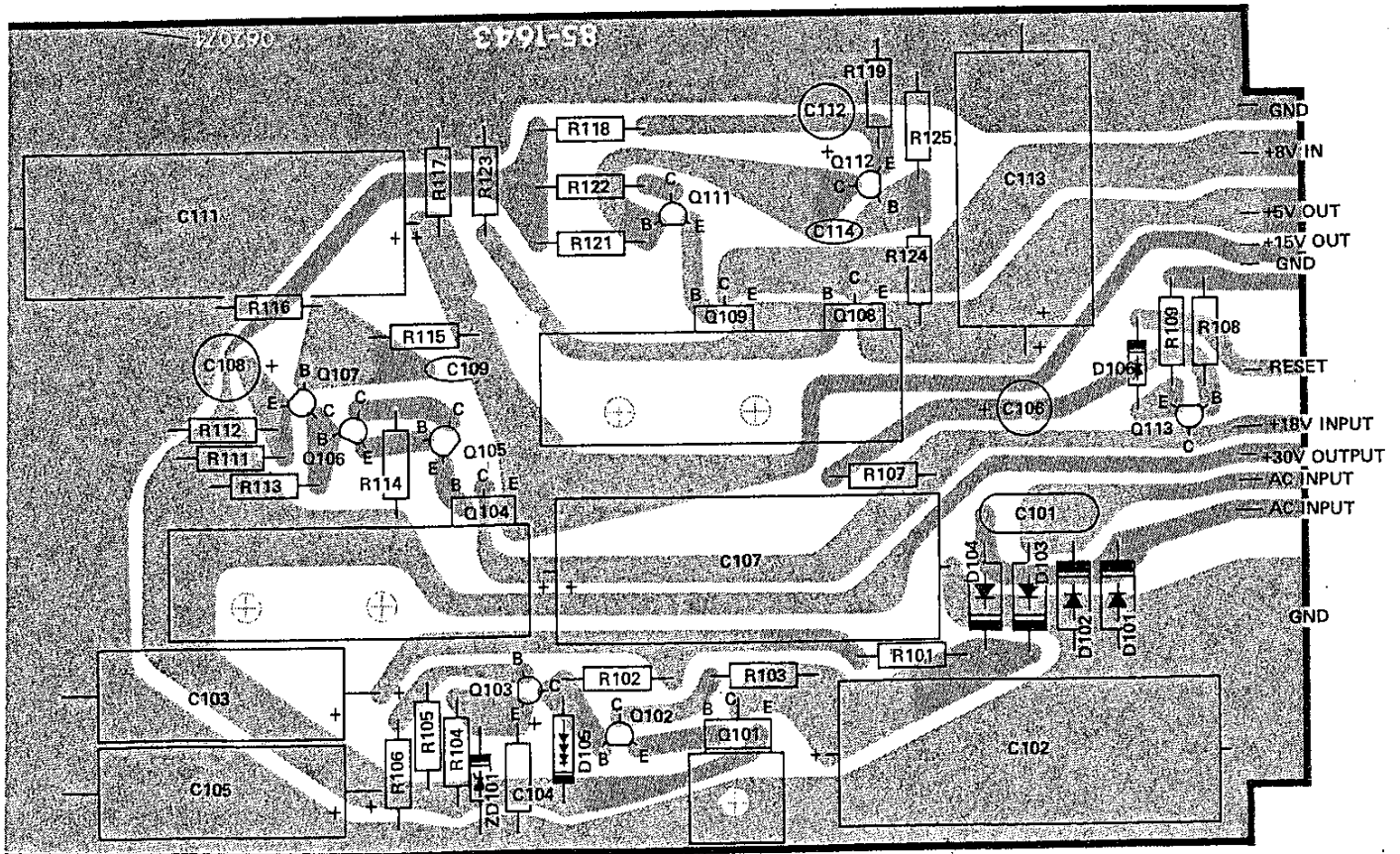

POWER SUPPLY CIRCUIT BOARD
(Viewed from foil side)

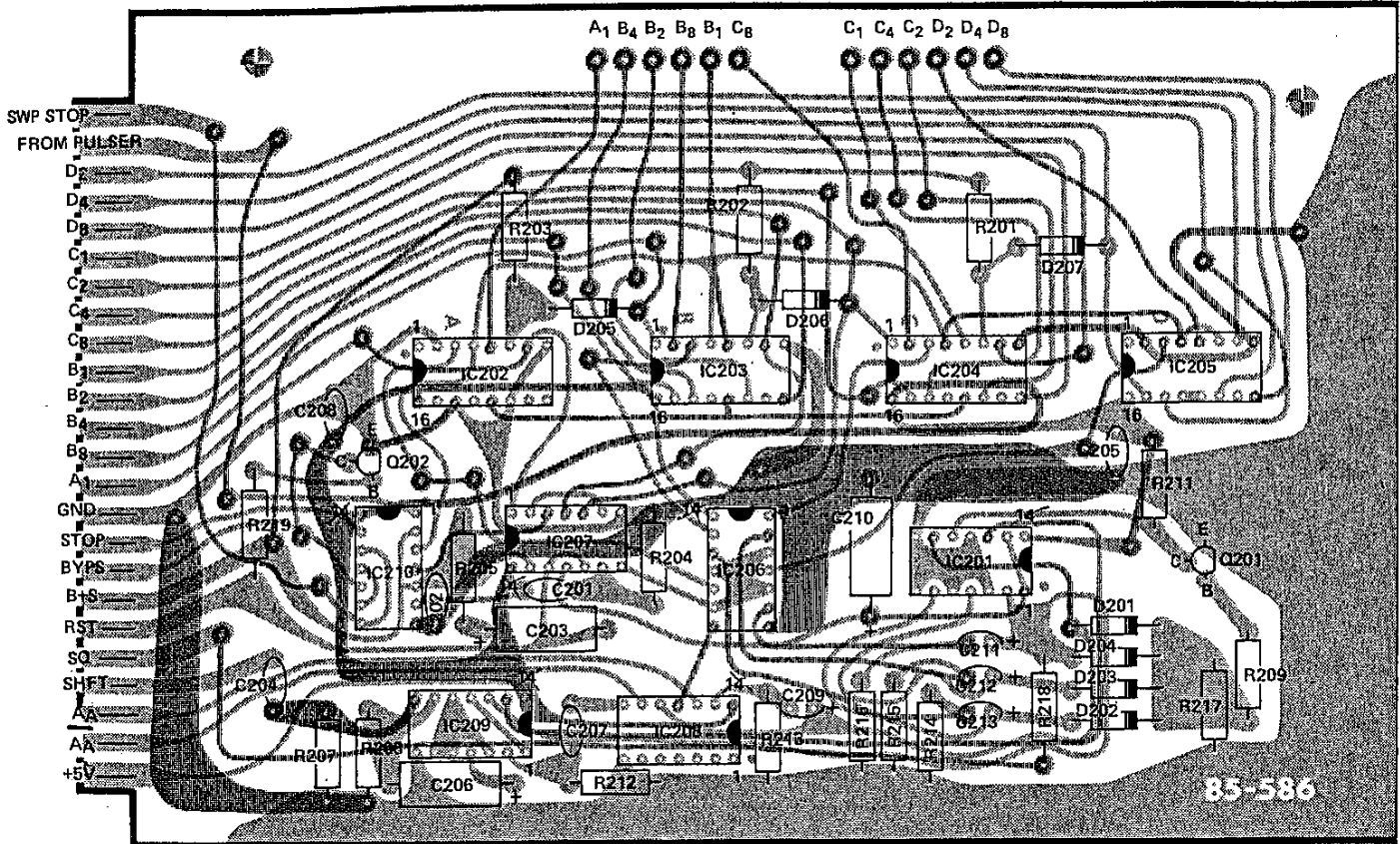

PROGRAMMER CIRCUIT BOARD
(Viewed from foil side)

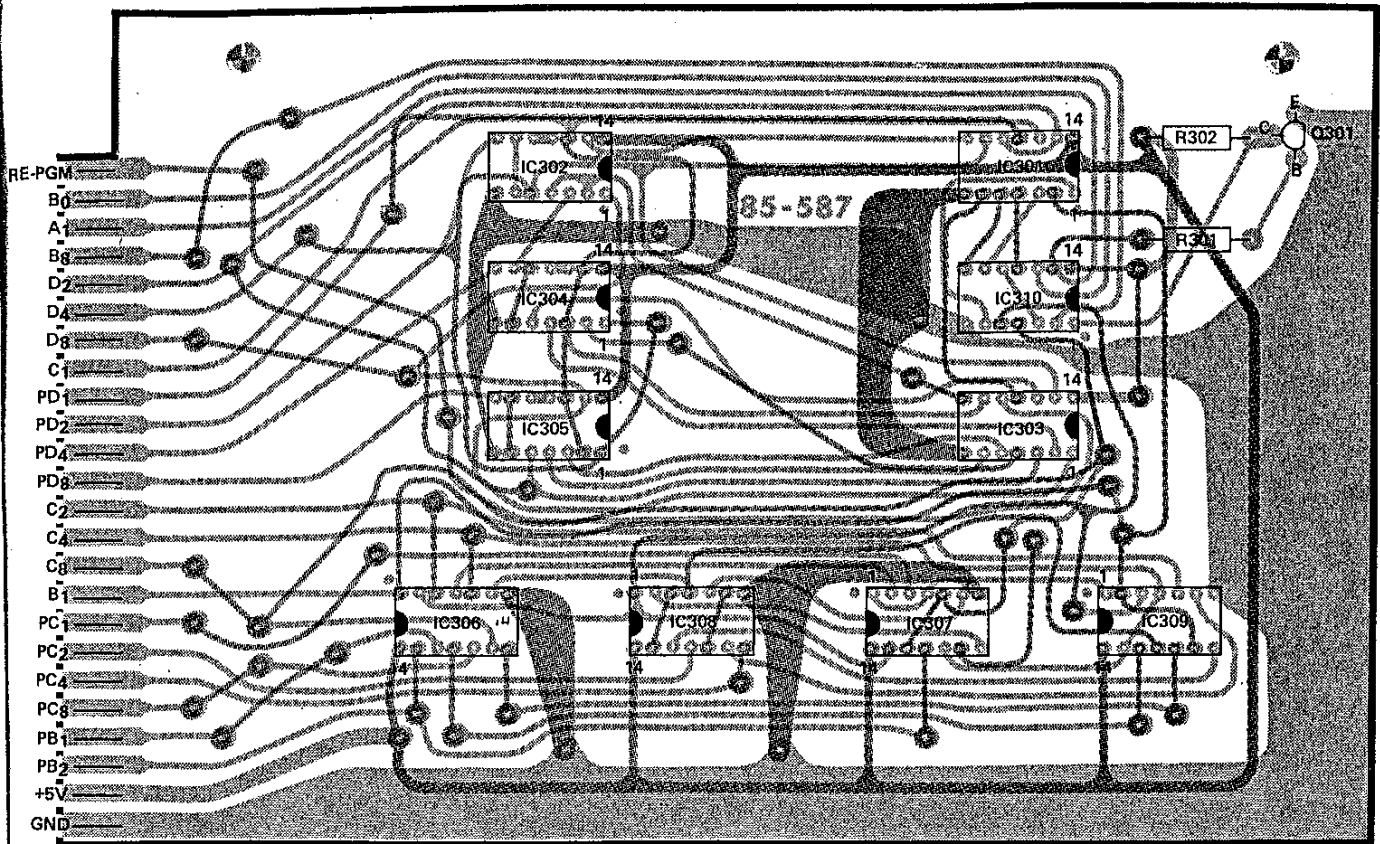

PRELOAD DECODER CIRCUIT BOARD
(Viewed from foil side)

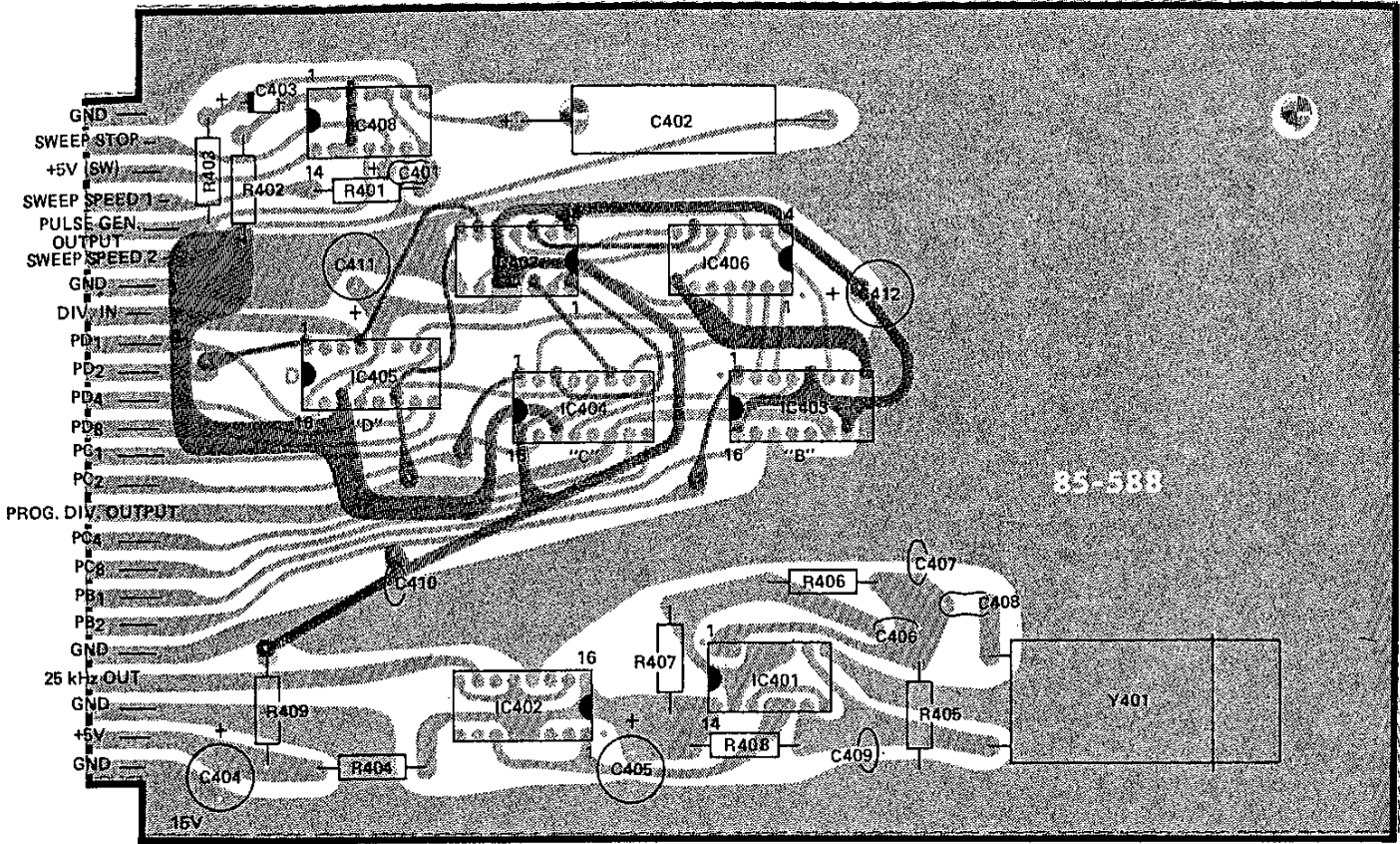

GENERATOR-DIVIDER-OSCILLATOR CIRCUIT BOARD
(Viewed from foil side)

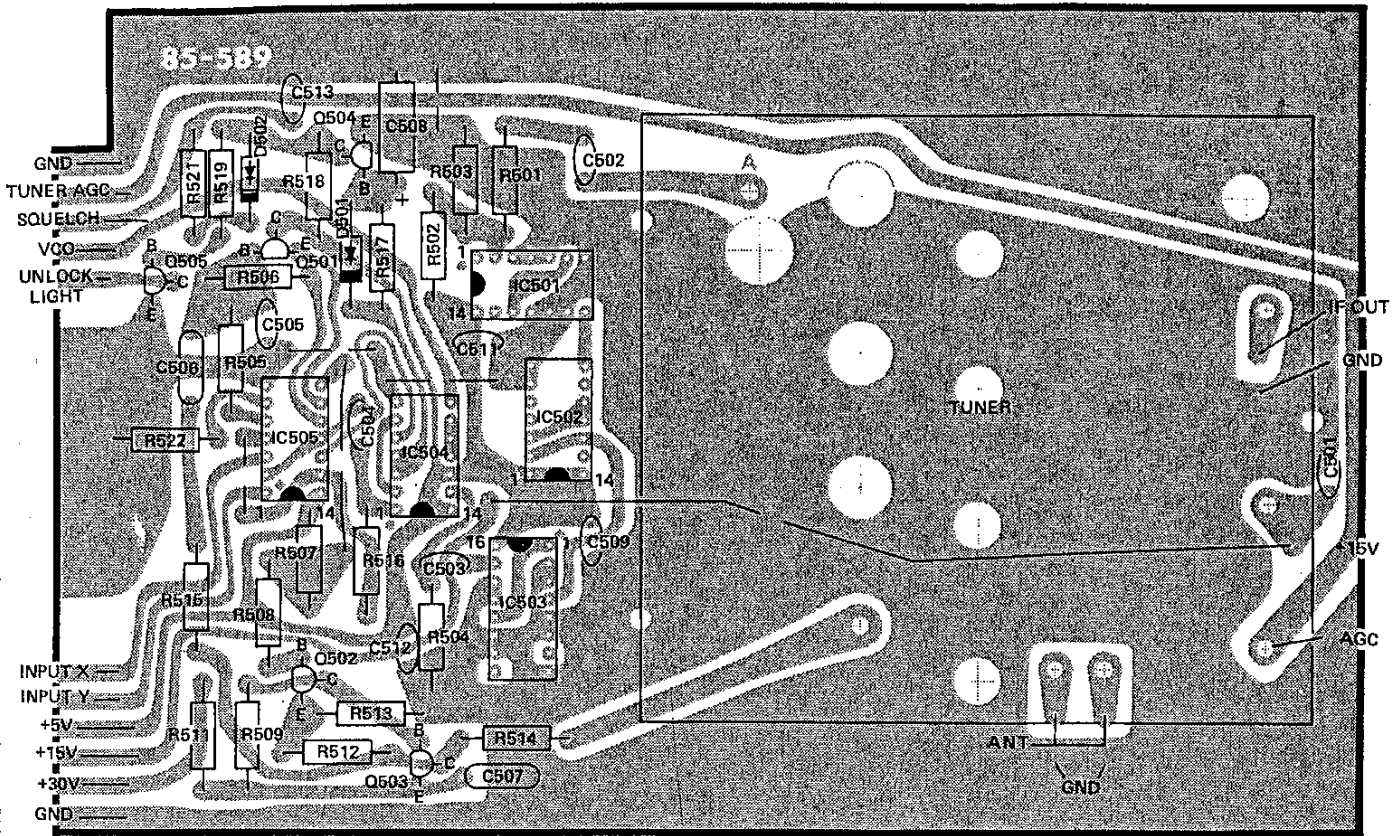

TUNER/PHASE-LOCK-LOOP CIRCUIT BOARD
(Viewed from foil side)

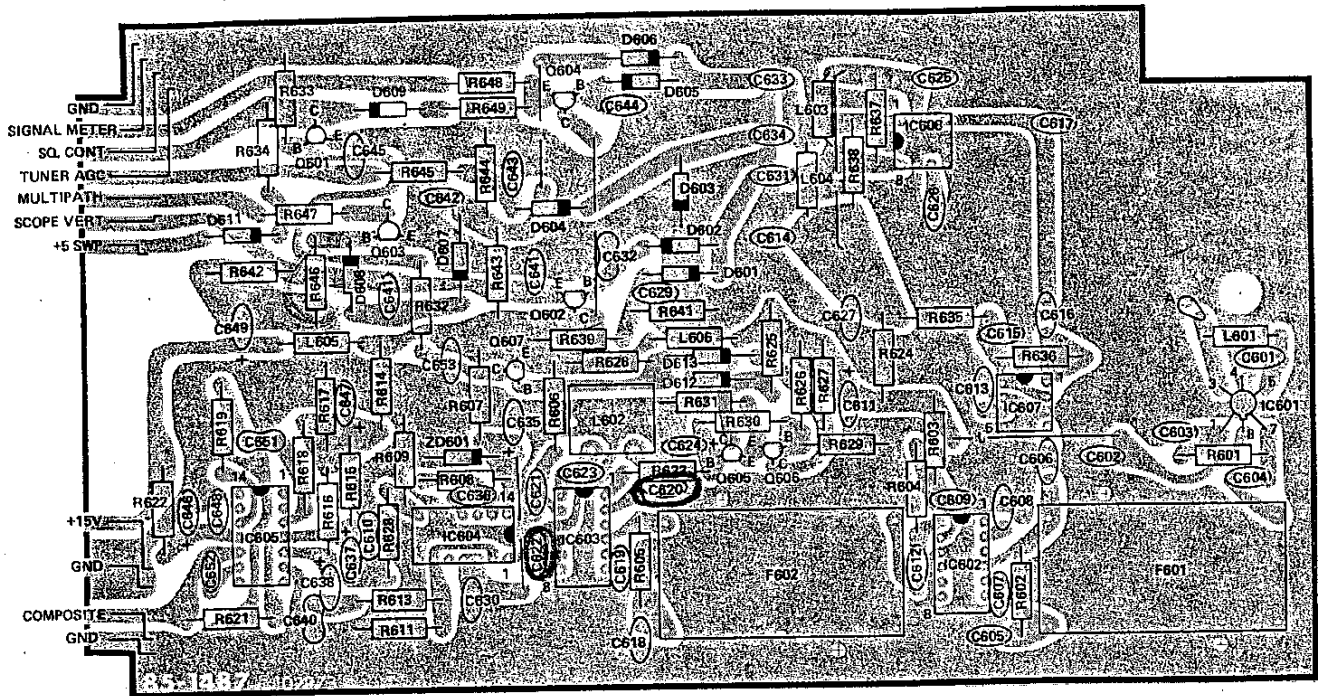

I-F CIRCUIT BOARD
 (Viewed from foil side)

R649, 5.6K

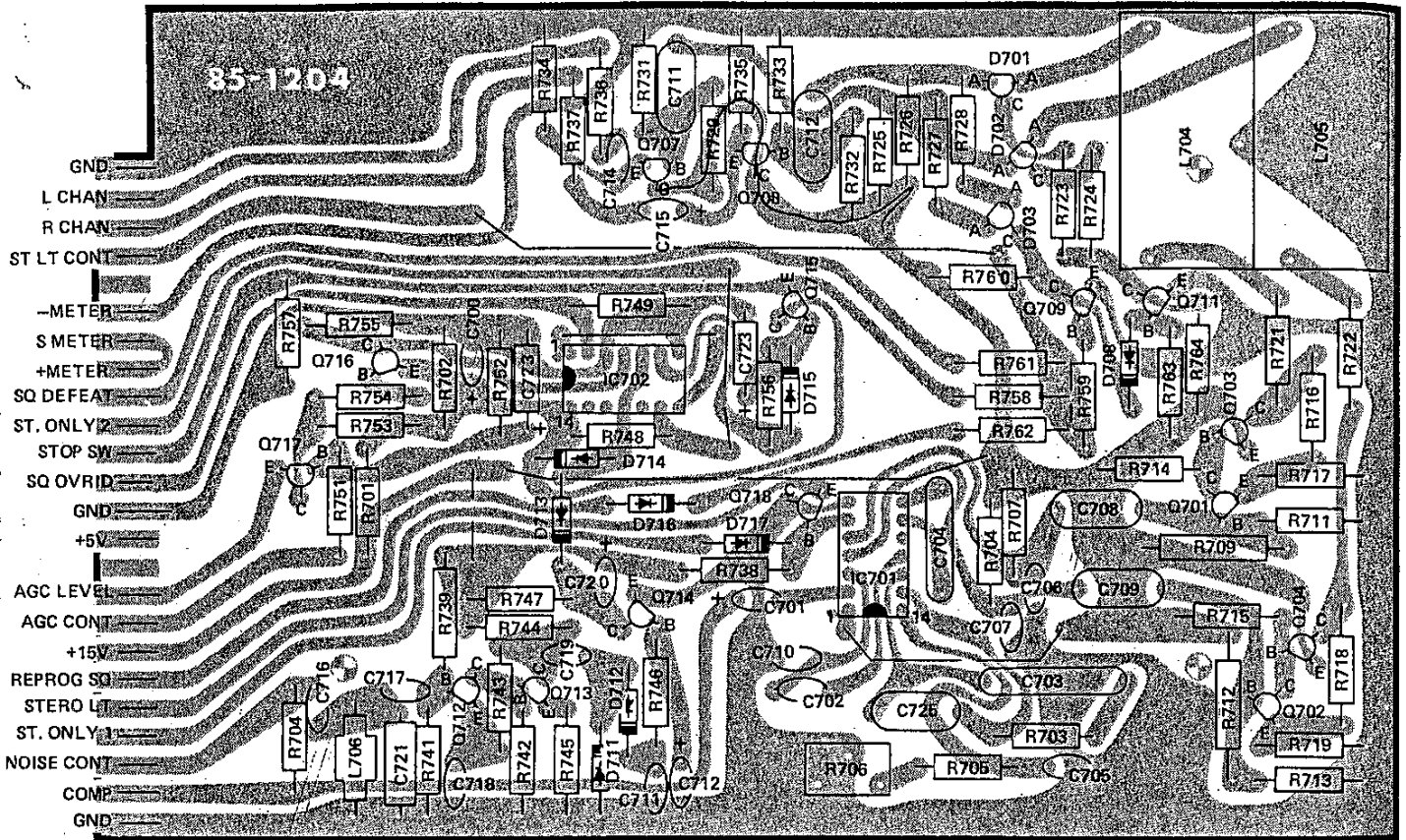

MULTIPLEX-DEMODULATOR CIRCUIT BOARD
(Viewed from foil side)

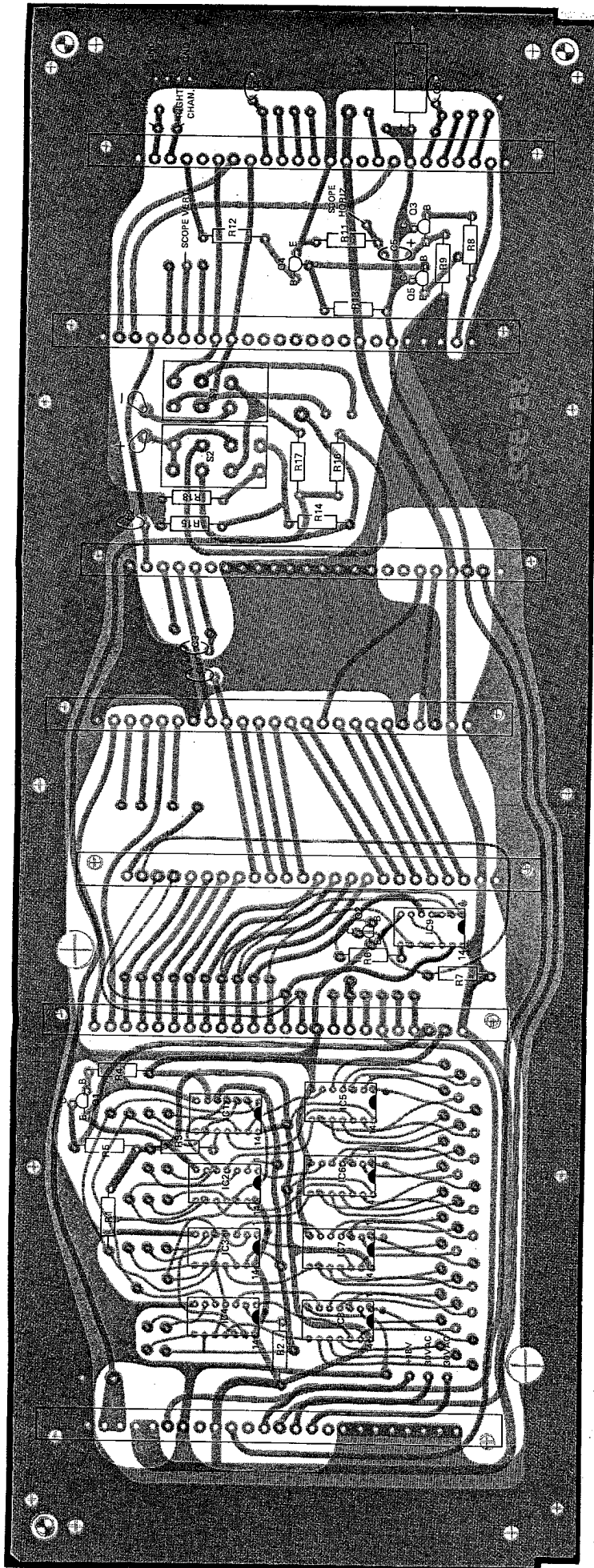

MASTER CIRCUIT BOARD
(Viewed from component side)

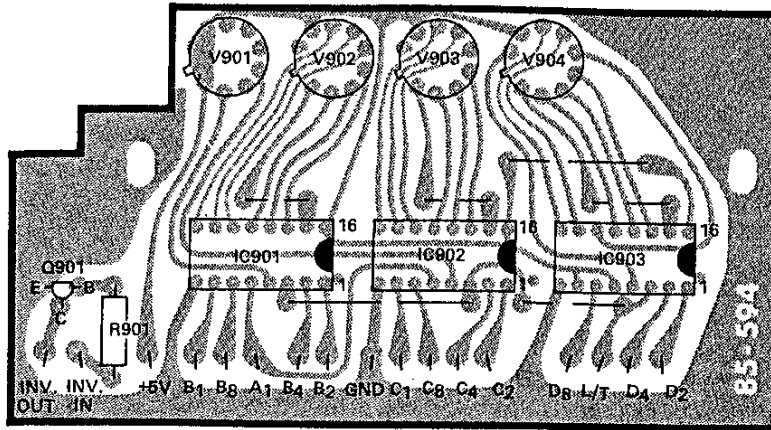

READOUT CIRCUIT BOARD
(Viewed from foil side)

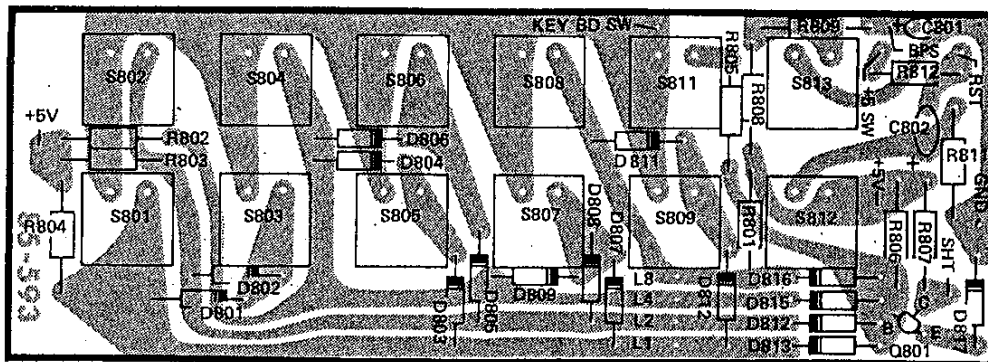

KEYBOARD CIRCUIT BOARD
(Viewed from component side)

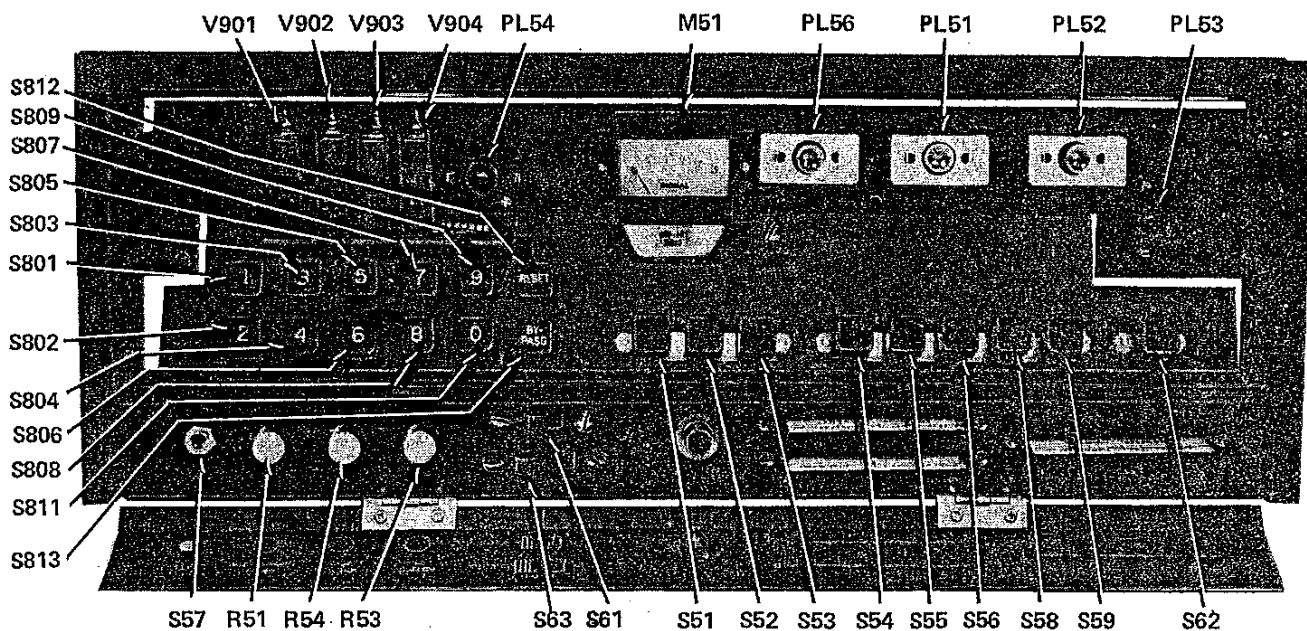

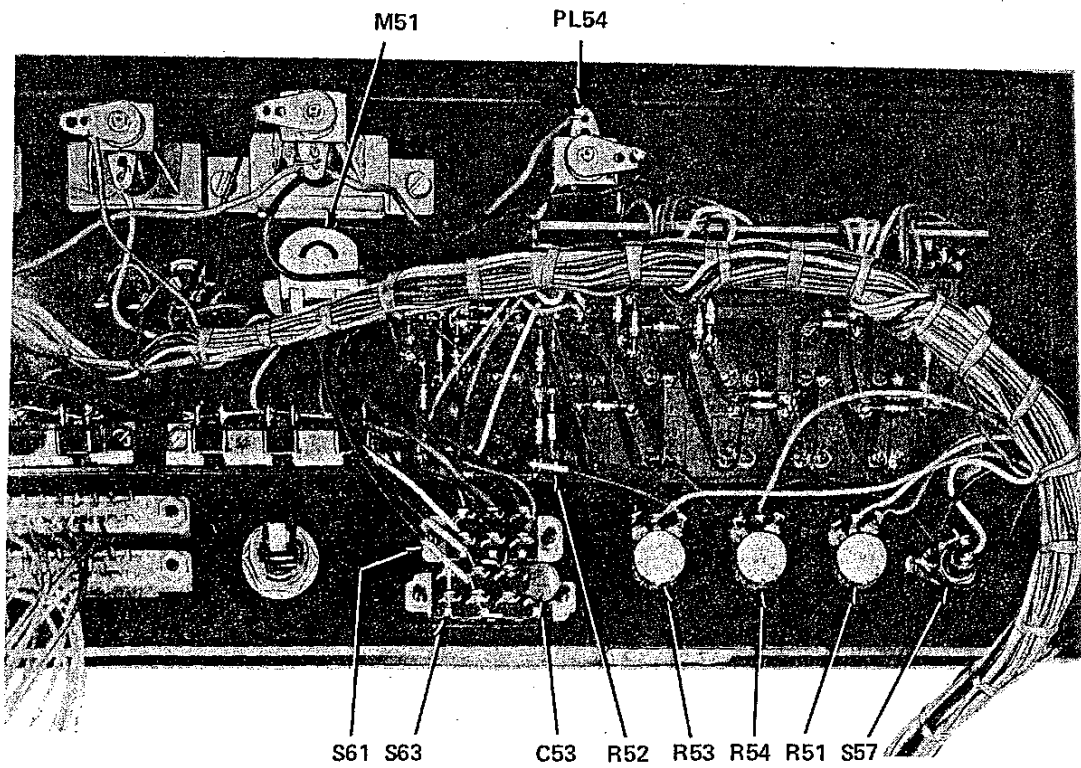
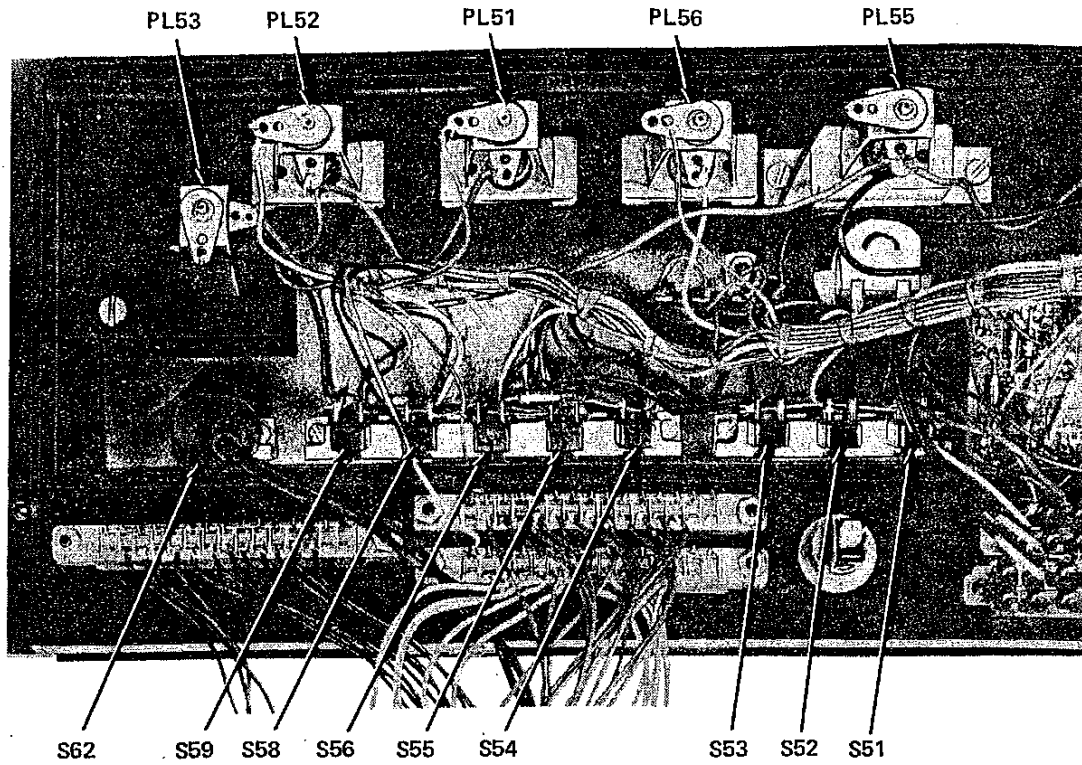

SEMICONDUCTOR CHART

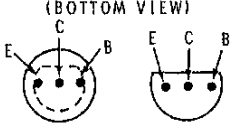
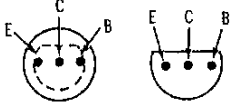
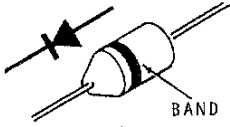
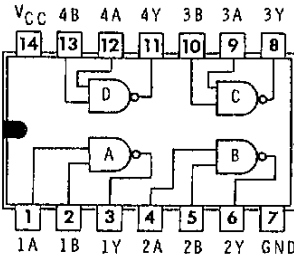
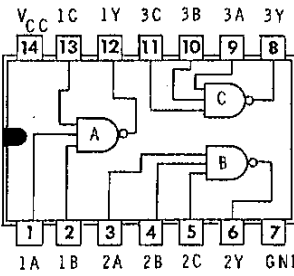
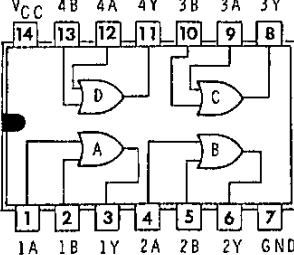
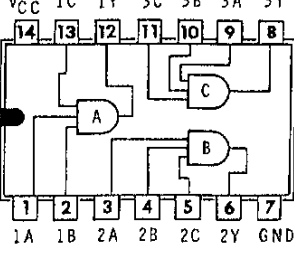
COMPONENT NUMBER	HEATH PART NUMBER	MAY BE REPLACED BY	DESCRIPTION	LEAD CONFIGURATION
Q1, Q2 Q3	417-118	2N3393	NPN TRANSISTOR	(BOTTOM VIEW) 
Q4, Q5	417-94	2N3416	NPN TRANSISTOR	
D51, D52	57-27	1N2071	SILICON RECTIFIER 600V, 1A	
IC2	443-1	SN7400N	QUADRUPLE 2-INPUT POSITIVE NAND GATES	
IC1 IC3 IC4	433-12	SN7410N	TRIPLE 3-INPUT POSITIVE NAND GATES	
IC9	443-57	MC3003P	QUADRUPLE 2-INPUT OR GATES	
IC5, IC6 IC7, IC8	443-58	MC3006P	TRIPLE 3-INPUT POSITIVE AND GATES	

CUSTOMER SERVICE

REPLACEMENT PARTS

If you need a replacement part, please fill in the Parts Order Form that is furnished and mail it to the Heath Company. Or, if you write a letter, include the:

- Part number and description as shown in the Parts List.
- Model number and Series number from the blue and white label.
- Date of purchase.
- Nature of the defect.

Please do not return parts to the factory unless they are requested. Parts that are damaged through carelessness or misuse by the kit builder will not be replaced without cost, and will not be considered in warranty.

Parts are also available at the Heathkit Electronic Centers listed in your catalog. Be sure to provide the Heath part number. Bring in the original part when you request a warranty replacement from a Heathkit Electronic Center.

NOTE: Replacement parts are maintained specifically to repair Heathkit products. Parts sales for other reasons will be declined.

TECHNICAL CONSULTATION

Need help with your kit? Self-Service? Construction? Operation? Call or write for assistance. You'll find our Technical Consultants eager to help with just about any technical problem except "customizing" for unique applications.

The effectiveness of our consultation service depends on the information you furnish. Be sure to tell us:

- The Model number and Series number from the blue and white label.
- The date of purchase.
- An exact description of the difficulty.
- Everything you have done in attempting to correct the problem.

Also include switch positions, connections to other units, operating procedures, voltage readings, and any other information you think might be helpful.

Please do not send parts for testing, unless this is specifically requested by our Consultants.

Hints: Telephone traffic is lightest at midweek. . . please be sure your Manual and notes are on hand when you call.

Heathkit Electronic Center facilities are also available for telephone or "walk-in" personal assistance.

REPAIR SERVICE

Service facilities are available, if they are needed, to repair your completed kit. (Kits that have been modified, soldered with paste flux or acid core solder, cannot be accepted for repair.)

If it is convenient, personally deliver your kit to a Heathkit Electronic Center. For warranty parts replacement, supply a copy of the invoice or sales slip.

If you prefer to ship your kit to the factory, attach a letter containing the following information directly to the unit:

- Your name and address.
- Date of purchase.
- Copies of all correspondence relevant to the service of the kit.
- A brief description of the difficulty.
- Authorization to return your kit C.O.D. for the service and shipping charges. (This will reduce the possibility of delay.)

Check the equipment to see that all screws and parts are secured. (Do not include any wooden cabinets or color television picture tubes, as these are easily damaged in shipment.) Place the equipment in a strong carton with at least THREE INCHES of *resilient* packing material (shredded paper, excelsior, etc.) on all sides. Use additional packing material where there are protrusions (control sticks, large knobs, etc.). If the unit weighs over 15 lbs., place this carton in another one with 3/4" of packing material between the two.

Seal the carton with reinforced gummed tape, tie it with a strong cord, and mark it "Fragile" on at least two sides. Remember, the carrier will not accept liability for shipping damage if the unit is insufficiently packed. Ship by prepaid express, United Parcel Service, or insured Parcel Post to:

Heath Company
Service Department
Benton Harbor, Michigan 49022

Mhz	6	3	-	0V	3	
S	6	5	-	5	3	
Steno	0V			<u>-1.50</u>		5
Res	0V			4.8		3
Cap	0V			4.2		1
<u>Price</u>	0V	1	-	8V	8	14

HEATH
Schlumberger

5.50 IC Excess
 4.00 Solder
 9.50

Book 2.00
 Diagram 5.00
 4 3.15
 0.25
 10.65

HEATH COMPANY • BENTON HARBOR, MICHIGAN
THE WORLD'S FINEST ELECTRONIC EQUIPMENT IN KIT FORM

LITHO IN U.S.A.