

CARVER

Model TX-11b



Quartz-Synthesized Stereo Tuner

- Ultra High Fidelity Wide Band AM Stereo
- Asymmetrical Charge-Coupled FM Detector
- Thirteen Station Presets
- Multipath Elimination Circuitry
- Noise Reduction

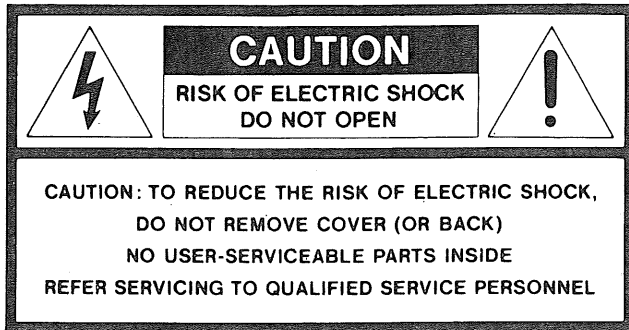

The lightning flash with arrowhead symbol, within an equilateral triangle, is intended to alert the user of the presence of uninsulated "dangerous voltage" within the product's enclosure; that may be of sufficient magnitude to constitute a risk of electric shock to persons.

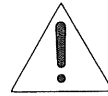

The exclamation point within an equilateral triangle is intended to alert the user of the presence of important operating and maintenance (servicing) instructions in the literature accompanying the appliance.

Safety Instructions

- 1 Read Instructions - All the safety and operating instructions should be read before the component is operated.
- 2 Retain Instructions - The safety and operating instructions should be retained for future reference.
- 3 Heed Warnings - All warnings on the component and in the operating instructions should be adhered to.
- 4 Follow Instructions - All operating and other instructions should be followed.
- 5 Water and Moisture - The component should not be used near water - for example, near a bathtub, washbowl, kitchen sink, laundry tub, in a wet basement, or near a swimming pool, etc.
- 6 Ventilation - The component should be situated so that its location or position does not interfere with proper ventilation. For example, the component should not be situated on a bed, sofa, rug, or similar surface that may block the ventilation openings; or placed in a built-in installation such as a bookcase or cabinet that may impede the flow of air through the ventilation openings.
- 7 Heat - The component should be situated away from heat sources such as radiators, or other devices that produce heat.
- 8 Power Sources - The component should be connected to a power supply only of the type described in the operating instructions or as marked on the component.
- 9 Power-Cord Protection - Power-supply cords should be routed so that they are not likely to be walked on or pinched by items placed upon or against them, paying particular attention to cords at plugs, convenience receptacles, and the point where they exit from the component.
- 10 Cleaning - The component should be cleaned only as recommended in this manual.
- 11 Non-use Periods - The power cord of the component should be unplugged from the outlet when left unused for a long period of time.
- 12 Object and Liquid Entry - Care should be taken so that objects do not fall into and liquids not spilled into the inside of the component.
- 13 Damage Requiring Service - The component should be serviced by qualified service personnel when:
 - A. The power-supply cord or the plug has been damaged; or
 - B. Objects have fallen, or liquid has been spilled into the component; or
 - C. The component has been exposed to rain; or
 - D. The component does not appear to operate normally or exhibits a marked change in performance; or
 - E. The component has been dropped, or the cabinet damaged.
- 14 Servicing - The user should not attempt to service the component beyond those means described in the operating instructions. All other servicing should be referred to qualified service personnel.
- 15 Power lines - An outdoor antenna should be located away from power lines.
- 16 To prevent electric shock do not use this (polarized) plug with an extension cord, receptacle or other outlet unless the blades can be fully inserted to prevent blade exposure.

**FIGURE 75. 1
EXAMPLE OF ANTENNA GROUNDING AS PER
NATIONAL ELECTRICAL CODE**

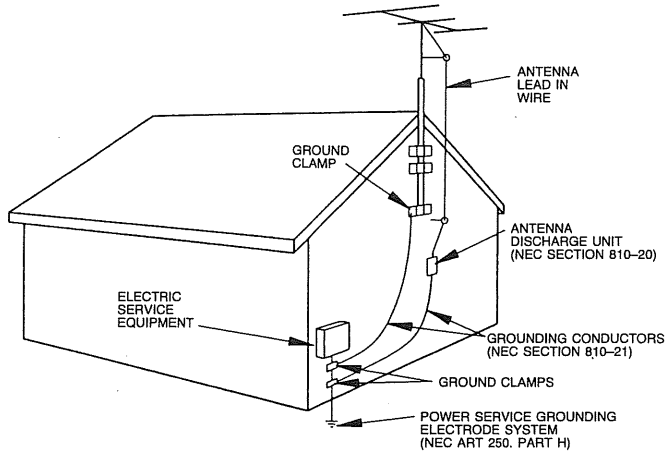

NEC - NATIONAL ELECTRICAL CODE

S2898A

Carts and Stands - The appliance should be used only with a cart or stand that is recommended by the manufacturer.

An appliance and cart combination should be moved with care. Quick stops, excessive force, and uneven surfaces may cause the appliance and cart combination to overturn.

PORTABLE CART WARNING



Pour prévenir les chocs électriques ne pas utiliser cette fiche polarisée avec un prolongateur, une prise de courant ou une autre sortie de courant, sauf si les lames peuvent être insérées à fond sans en laisser aucune partie à découvert.

electrodes, and requirements for the grounding electrode.

17 Grounding or Polarization - Precautions should be taken so the grounding or polarization means of the component are not defeated. Section 810 of the National Electrical Code, ANSI/NFPA No. 70-1984, provides information with respect to proper grounding of the mast and supporting structure, grounding of the lead-in wire to an antenna discharge unit, size of grounding conductors, location of antenna-discharge unit, connection to grounding

Table Of Contents

SAFETY INSTRUCTIONS	3
I. INTRODUCTION	6
II. PLACEMENT, INSTALLATION, AND REAR PANEL CONNECTIONS	7
III. CONTROLS AND FUNCTIONS	9
IV. MULTIPATH/NOISE REDUCTION AND THE ASYMMETRICAL CHARGE-COUPLED FM DETECTOR™ ..	11
V. ANTENNAS	
FM	12
AM	16

VII. APPENDIX

Section 1 FM Stereo Signals and the Asymmetrical Charge Coupled FM Detector	18
Section 2 AM Stereo Signals and the Ultra High Fidelity Wide Band AM Stereo	18
Section 3 Specifications	20
Section 4 Troubleshooting	21
Section 5 Warranty	22

*U.S. Patent 4,457,012

IMPORTANT! The TX-11b's memory preset switches are sensitive. Use a **gentle**, on-center touch, don't push them too hard, or they may jam.

WARNING! To prevent fire or shock hazard, do not expose this equipment to rain or moisture.

If you wish to engage the NOISE and MULTIPATH REDUCTION switches simultaneously, use **two** fingers. Using one on both buttons could jam them.

TO AVOID ELECTRICAL SHOCK, DO NOT OPEN CHASSIS. NO USER-SERVICEABLE PARTS INSIDE. REFER ALL SERVICING TO QUALIFIED PERSONNEL.

CAUTION: When installing this equipment, read and follow all safety and operating instructions.

NOTE! To CATV system installer –

This reminder is provided to call the CATV system installer's attention to Article 820-22 of the NEC that provides guidelines for proper grounding and, in particular, specifies that the cable ground shall be connected to the grounding system of the building, as close to the point of cable entry as practical.

Personal Warranty Information

Serial Number: _____

Dealer: _____

Date of Purchase: _____

Personal ID Number/Location: _____

Introduction

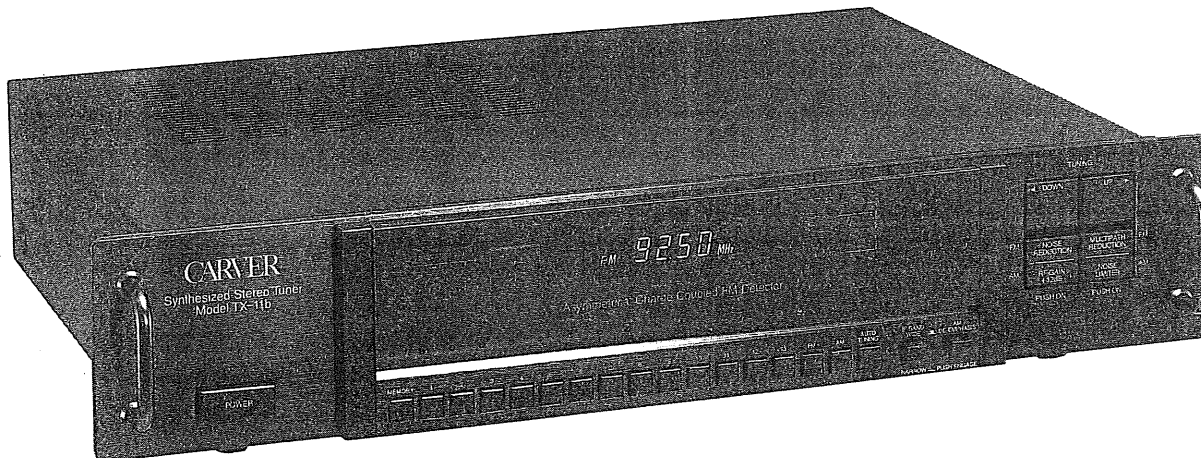

Congratulations! You've purchased the finest tuner available: the Carver TX-11b Quartz Synthesized Stereo Tuner with Asymmetrical Charge-Coupled FM Detector™ and Ultra High Fidelity Wide Band AM stereo (utilizing Motorola's CQUAM™ system). Your new tuner's special FM circuitry is Bob Carver's brilliant solution for eliminating the distortion and noise that usually make FM listening a less than pleasurable experience. When engaged, these patented circuits enable the TX-11b to literally pull music from the morass of hiss and distortion associated with multipath interference. You'll be able to consistently, cleanly, quietly enjoy the music in STEREO. The ambience and localizing information needed to perceive stereo, also lost to distortion, is restored. Finally, a real breakthrough that makes FM programming compete equally with records and tapes for audio quality, and share of your listening time.

The TX-11b has been exceptionally engineered, and is superbly crafted for more than sonic excellence. Your tuner has many sophisticated features that will enhance your enjoyment of stereo listening, now, and in the future. To take full advantage of all this, be sure to read the safety, installation, and operating instructions. We've prepared this owner's manual for learning about the concepts, controls, and functions that make the TX-11b a superior tuner in every way. We've included even more information on getting the most from your new tuner. See ANTENNAS, and the Appendix of this manual to ensure you are getting the very best sound you deserve.

Warranty Card

Please, fill out and return the Warranty Card that came with the TX-11b's packing kit. It's highly unlikely your TX-11b will ever need service, but should the unlikely occur, your Warranty Card is **the** ticket to Carver's two years limited Parts/Labor Warranty repair. Either from a local Authorized Carver Service Center, or the factory. We also suggest you fill out the warranty information in the space we included on the preceding page. Be sure to include any personal ID number used in further identifying the TX-11b.

Before Going any Farther . . .

Here are some suggested do's and don'ts that will make setting-up and using the TX-11b a safe, as well as enjoyable experience:

- Don't operate the TX-11b on any other power line voltage other than that specified on the rear panel.
- Make all connections to and from the TX-11b with its power, and power for all other components in your system, switched OFF.
- Unplug the TX-11b's power and antenna lead-in during electrical storms, or if you're not going to use it for a prolonged period of time.
- When unplugging the ac line cord, grasp the plug and pull; don't yank on the cord itself.
- If someone accidentally spills a drink on the TX-11b's cabinet, unplug the tuner and have it checked out or cleaned by a qualified service technician. This applies to every piece of equipment in your stereo system.
- Of course, we've mentioned that there aren't any user-serviceable parts inside your TX-11b. Please, resist any temptation to fiddle around inside the TX-11b. Avoid possible electrical shock and/or extreme embarrassment. Refer **all** service work to a qualified technician.

Again, keep the carton and packing material the TX-11b came in. Should you move, the best shipping container is the original carton. Hang on to this owner's manual, too. When your music system gets to its new home, the safety, installation, and programming instructions could be more than useful. Also, please fill out and return the warranty card, if you haven't already done so. In the remote possibility your TX-11b ever needs repair, the warranty card is a passport to speedy, efficient service from either a local Authorized Carver Service Center or the factory.

Installation

To perform the basic installation and set-up of the TX-11b, you'll need shielded signal leads (dual RCA phono plug to phono plug), and the half-wave dipole antenna, loop antenna, and wire that came in the box along with this manual. If you're planning to install the TX-11b handles, a philips-head screwdriver will be needed.

Placement

Place the TX-11b near the preamp – near enough so the signal cable will reach without excessive strain on the cable itself, or on the connections.

Heat, at least normal amounts, shouldn't be any problem. The tuner itself doesn't generate much and isn't sensitive to small amounts. But, you should never mount the TX-11b directly on top of power amplifiers. Unless your system uses Carver Magnetic Field Amplifiers, conventionally designed amps can, and do, generate a lot of heat. Plus, the tuner's chassis could block vents needed for proper cooling of the amps. If your equipment rack or component cabinet is completely enclosed, forced-air cooling with a small "rack fan" will prolong the life of the electrical devices in your stereo components. These rack fans quietly move between 40 and 120 cubic feet of air per minute, come in different sizes, and may be obtained from electronic supply stores or your stereo dealer. We also recommend using a filter with the rack fan to minimize dust in the enclosure. Be sure you clean the filter regularly.

Never mount or locate the TX-11b in direct sunlight, near forced-air vents, near motors, or other sources of dust and possible interference.

Cleaning

It's a good idea to wipe the TX-11b's cabinet from time-to-time with a soft, dry cloth. If you have to get something off, use a mild dish soap or detergent: don't use alcohol, ammonia, or other strong solvents.

Signal Connections

When it comes to making signal connections between the tuner outputs and preamp inputs (for integrated amps, too), be sure to plug the left side into the left tuner input of the preamp, the right side into the right tuner input.

As mentioned earlier, the signal cable should reach without straining cable or connections. In the event that the signal leads don't reach, or simply aren't long enough for your special installation, substitute cables can be obtained from a stereo dealer or electronic supply shop. It's recommended that any other cables used be shielded, and not exceed 20 feet in length. This will help minimize possible noise or interference.

Power

Plug the TX-11b power cord into either a switched or unswitched convenience receptacle of the preamp or integrated amplifier. Don't force the plug, do it carefully. If these receptacles are taken up by power amps, turntables, or other components, a multireceptacle power bar should be used. Plug the TX-11b, and other additional components in the system, into the power bar (including the preamp itself). Make certain the power bar is rated to handle the total maximum wattage of all the components in your stereo system. Plug the power bar into a wall outlet.

Make sure the volume-control on the preamp is turned down or off before switching on the power of any component in your stereo system.

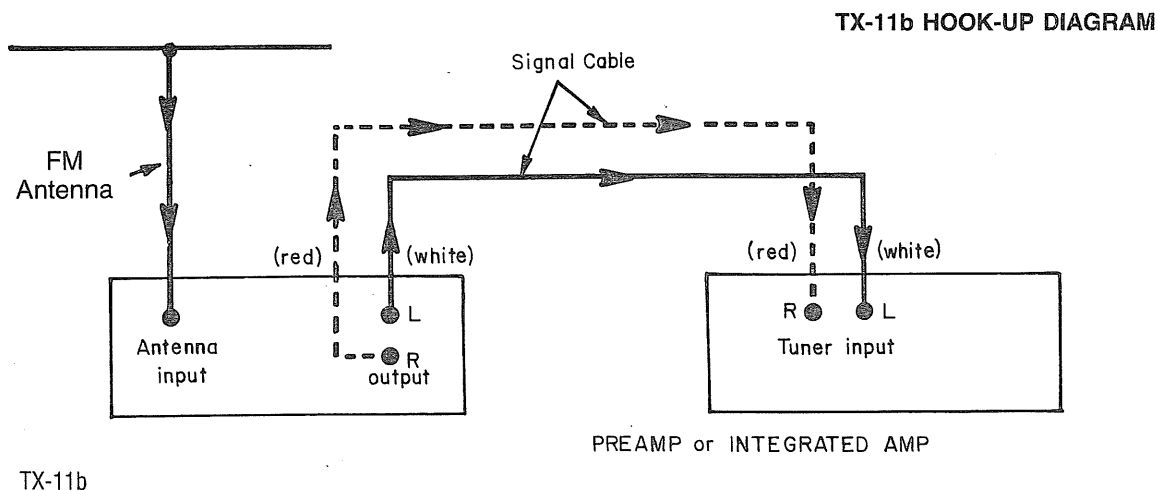

Grounding

While grounding an outdoor antenna is vitally important, there's normally no need to ground the tuner itself. But with safety and possibly reduced interference in mind, you may want to ground the tuner chassis. If so, run a heavy (12-gauge or heavier copper/alum.) wire from the tuner to a **metal** cold water pipe. You'll have to check to make sure the metal pipe is grounded; PVC (plastic) pipes are sometimes run in from the water main to the house, then metal pipes are used within the house. **NEVER** attach a ground wire to a gas pipe, either for your components, or antenna. The best grounding scheme is a ground rod driven several feet into the earth. See the chapter on ANTENNAS for information on installing a ground rod.

Antenna Terminals

AM

Two AM antennas have been provided with your TX-11b. Experimentation will tell you which antenna works best for your location. See the chapter on ANTENNAS for further informaton.

AM Loop Antenna

The first is a high performance, noise-free AM loop antenna held on the rear panel with a snap-in hinge. Swivel it out for best reception. You may also remove the antenna from its hinge and attach it to a nearby wall. The length of the antenna cord is 2 feet and should not be pulled tight.

Securely connect the loop antenna leads to the AM and GND terminals.

AM Wire Antenna

The second AM antenna is a wire that attaches to the AM terminal of the TX-11b. This wire will increase AM sensitivity, and we highly recommend its use for AM stereo reception.

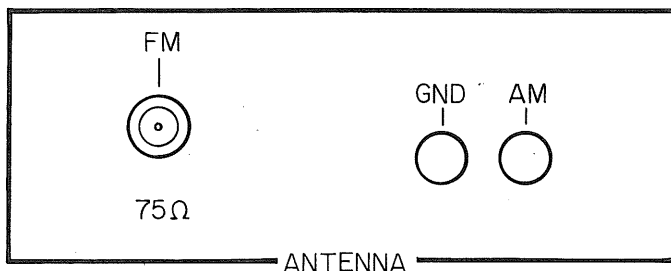

FM

You can either connect directly to your local Cable Television System for FM (consult your Cable Operator) using coaxial cable, or use the supplied 75/300 ohm adaptor and dipole ribbon antenna. Caution should be used when connecting your Preamp/Tuner to an external outside TV/FM antenna. See Notice located in the front of this manual. If uncertain, please refer to qualified personnel. If hum occurs when using the 75 ohm terminal, install a 75/300 ohm balanced transformer to the coaxial cable, and reconnect to the supplied 300 ohm to 75 ohm adapter to break the ground loop that is causing the offending hum.

A commercial cable company, as a matter of procedure and policy, most often connects a tuner using the 300 Ω antenna terminals. Few tuners have provisions for direct connection to 75Ω feeds. Normally, a feedline from a FM trap is connected with a matching transformer (75 Ω to 300 Ω) to the 300 Ω antenna terminals by the cable company installer. Their transformers come with spade lugs on the leads, and are the same type used to terminate a regular TV cable at the VHF antenna terminals of a TV set. NOTE: It isn't legal to "do-it-yourself" and tap into a commercial cable TV system without telling the cable company. So, don't do it . . . even if you know how!

If you can talk the installer into connecting the cable feed directly to the 75 Ω terminals, ask to have a female to female coaxial connector inserted between the main feed from the FM trap and a shorter piece of cable connected to the tuner. This provides an easy disconnect for the cable lead-in, without unhooking it at the TX-11b's rear panel. This is an especially good idea for those who will use 75 Ω coaxial cable with their own antenna systems for quick disconnect during electrical storms.

Controls & Functions

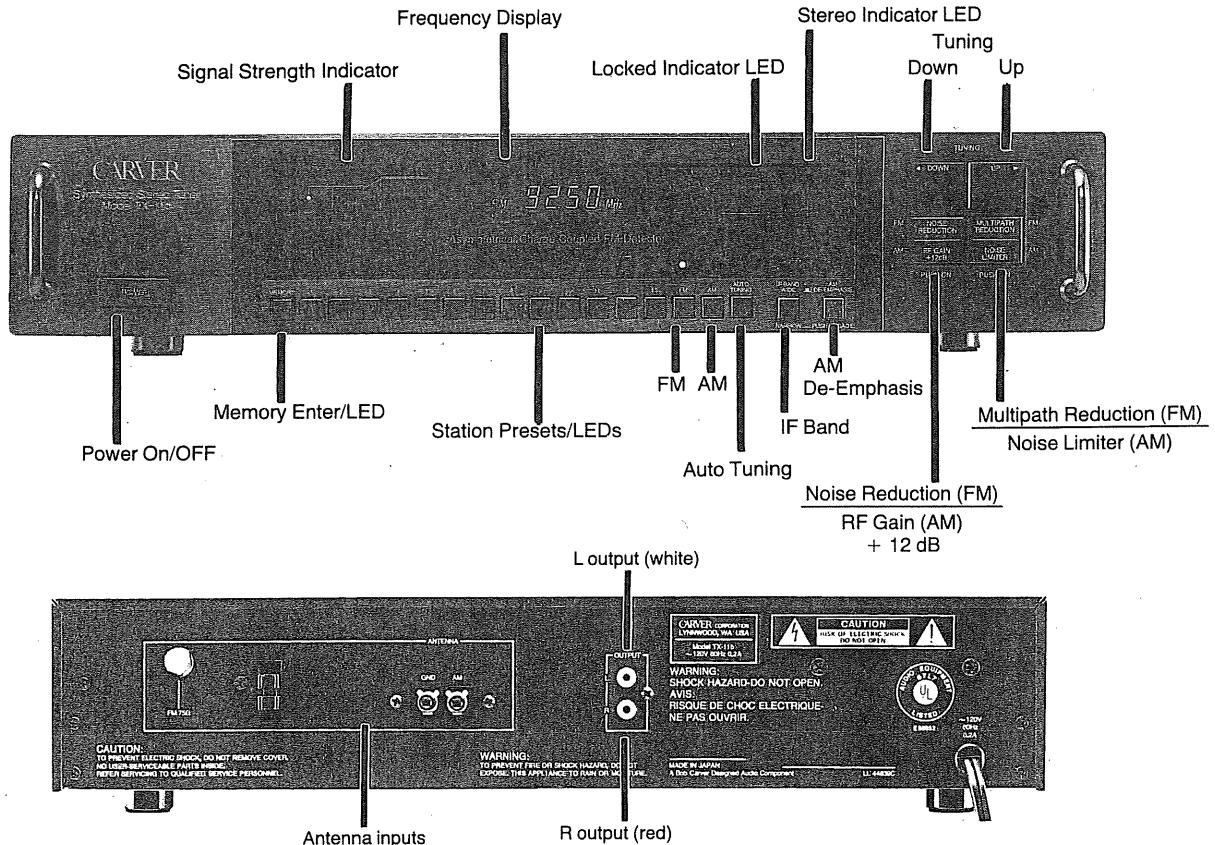

Power

The POWER switch on the lower lefthand side of the TX-11b turns the unit on or off. When you power up, the tuner will be tuned to the same station you were listening to before power was switched off.

Tuning

What Happens When You Tune the TX-11b?

The first in the chain of events that go on inside a tuner is the frequency tuning itself. Here the Carver TX-11b uses a phase-locked loop with digitally synthesized tuning controlled by a 4-bit microprocessor.

What happens is this: a crystal-controlled oscillator runs at an exact frequency which is then divided down. Meanwhile, a local oscillator is tuning to the station's frequency which is lowered by a programmable divider. The phase of the two reduced frequencies is compared, and once they match exactly, the LOCKED light goes on and phase-locked loop takes over. The phase-locked loop is a circuit that compares the phase of the tuned frequency and the reference frequency continuously. If the tuned frequency drifts, the comparator brings it right back.

Manual Tuning

With the TX-11b on, press the Auto tuning momentary switch. The Auto LED will go out, and you can press either the DOWN or UP control buttons to change frequencies. One push gets you a change of 0.1 MHz. Holding the button results in a more rapid change of frequencies. Stop when you get to a station's exact frequency. If you're not quite sure what the exact frequency is, use the SIGNAL STRENGTH INDICATORS and "LOCKED" INDICATOR L.E.D.

If you try to tune lower or higher than the frequency limits (87.5 MHz low, 108 MHz high), the tuner will not change frequencies; you'll have to push the other tuning button.

The TX-11b's threshold circuitry is defeated during manual tuning; this will allow reception of a weak or extremely distant station. More about this in a bit.

Automatic Scan Tuning

Make sure the AUTO tuning LED is on. Then press either the UP or DOWN button. The tuner will change to the next higher or lower station with a signal strong enough to defeat the muting circuitry of the TX-11b. The automatic interstation muting circuit is engaged during tuning (in both MANUAL and AUTO modes). If you hold the UP or DOWN buttons down during the auto tuning, the tuner will skip past stations until you let go.

If you scan past the last station on the dial going in one direction, the tuner will search to the end of the tuning range, then "turn around" and start scanning in the opposite direction.

NOTE: In order to receive signals below 15 μ V (very low power, or distant stations), it will be necessary to switch the TX-11b to MANUAL tuning otherwise these low-strength stations will be cancelled by the muting circuitry. Tune these stations as we described in the preceding section on MANUAL TUNING.

Programming

Select AM or FM by depressing the momentary switch for AM or FM band. An LED above the switch will indicate band selection. Simply tune to a station or frequency you want to program. Push the MEMORY button (on the far left side of the 13 program switches below the display), then any one of the 13 station preset switches. Any preset can be programmed for AM or FM.

Once you've pushed the MEMORY button, the red LED above it will stay lit for about ten seconds, or until you push one of the station preset switches. The station you selected will be stored in the memory. Repeat the process for the next station.

Remember that using the manual tuning mode will allow you to receive more distant stations or weaker signals, because the threshold circuitry isn't operating during manual tuning. These stations, weak and/or distant, can still be stored in the TX-11b's station preset memories.

Programmed Tuning

Just press one of the station preset switches that has a frequency programmed into it. Automatic muting will be engaged until the station is locked in, and the red LED above that preset switch will light up. Programmed tuning is possible regardless of the MANUAL/AUTO switch position.

It might have crossed your mind, but what happens to stations you've programmed after the TX-11b is switched off? Programmed stations remain stored in the memory system, even with the tuner unplugged for up to three weeks.

We've also included a handy station log to write down the frequencies and call letters of the stations and program sources (on the last page of the Appendix). Yes, it's possible to fill up all 13 station presets on the TX-11b. Often with stations you've ignored in the past due to annoying noise or poor quality reception. Since 13 stations can be a lot for anyone to memorize, just jot the information down in the log for future reference.

Signal Strength Indicators

The SIGNAL indicators show you the strength of the signal the TX-11b is receiving. To the left of the frequency display, the SIGNAL indicators are arranged in 10 dB steps from 20 dB to 80 dB. The higher the reading on the indicators, the stronger the signal being received.

Locked Indicator

The LOCKED indicator lights when the tuning circuit has locked precisely onto the frequency of the station you've tuned.

Stereo Indicator

This indicator lights when the TX-11b is receiving the 19 kHz pilot of a stereo multiplexed signal for FM, or the 25 Hz pilot for stereo AM. If the STEREO indicator does not light, yet the station is positively locked with a strong signal, it may be the station is mono.

IF Band

This switch controls the IF filter circuit the TX-11b uses. It's useful when stations are close enough together on the band to start causing interference. Push in (NARROW) this control to decrease the IF bandwidth when you're trying to tune a station, and get a nearby station causing this type of problem. If crowded airwaves aren't a problem in your reception area, you should have the control off (WIDE) to get improved dynamic range. The IF switch works in both AM and FM bands.

When switching from one IF mode to the other, the TX-11b's muting system will be engaged briefly, approximately 1½ seconds.

AM De-emphasis

This AM stereo tuner is absolutely unique in that it possesses performance capability that is similar to the performance capability of an FM tuner. It has bandwidth that extends to 15 kHz and all its other specifications are very similar to FM specifications. This radio has the capability of sounding like an FM set. As you may or may not be aware, FM receivers have a deemphasis curve that is expressed in microseconds. The emphasis for FM is 75 microseconds. This AM radio also has a deemphasis curve that allows noise free high fidelity listening. This switch should be engaged, pushed IN. The reason that there is a switch on the front panel is that not all AM stations use a deemphasis curve because AM stereo is fairly new.

However, we have found that every single AM station in the Seattle area does indeed use a preemphasis curve that requires the use of a deemphasis curve. The switch should always be in the IN position for normal use. You'll notice that it comes from the factory taped IN. We have been unable to find a single case in which the button should be OUT but we know that theoretically, somewhere in the country, there is a radio station that probably does not use a preemphasis curve for broadcasting. If the button is left out while you listen to a radio station with preemphasis, it will sound much too bright and much too noisy.

The frequency response of this AM tuner is flat from below 20 Hz to 15 kHz, the same specifications that an FM system has. Using the deemphasis switch allows approximately a 10dB increase in signal to noise over the signal to noise that we would obtain without a deemphasis switch. That's the same reason FM has it, and almost everything has deemphasis and preemphasis. Cartridges have it – it's called the RIAA curve. FM has it; it's called 75 microsecond, CD players have it; that is why we have included it – to give the TX-11b best possible fidelity.

RF Gain + 12 dB (AM)

Push this switch in to increase the sensitivity for AM stations that are very weak and/or very far away.

The proper operating position for this switch is pushed in and left that way, just like the noise reduction button is supposed to be pushed in and left that way for normal use. On this unit, RF gain plus 12dB button and the noise reduction button are one in the same and are automatically switched from AM to FM depending on whether you listen to AM or FM. For both noise reduction FM and RF gain for AM you are supposed to leave this button pushed in all the time.

For AM, if you have an overload condition, or hear two stations, one on top of the other indicating an overload, then release the RF gain switch and this will always eliminate the offending overload and it will usually eliminate the two stations on top of one another. If it does not, then you have to push in the IF wide narrow switch to reduce the IF response of the AM receiver and this will eliminate this problem of two stations on top of one.

Noise Limiter (AM)

Push this switch to engage the impulse noise limiter for AM stations. This circuit will eliminate periodic, low duty cycle interference, such as that caused by fluorescent lights, thermostats, light dimmers, and so on.

Pushing this button engages an impulse noise limiter for AM stations. This switch is very effective for reducing and virtually eliminating impulse type noises associated with AM reception. It works best on impulse noises that are locally generated. The normal position for this button is in the OUT Position. This button does dual duty along with the multipath reduction on FM, which is also supposed to be in the OUT position. The normal position for this button is OUT for AM and FM.

Noise Reduction (FM)

Push this switch to engage the noise reduction part of the Asymmetrical Charge-Coupled FM Detector™*. Use this switch gently, pushing it carefully in the center.

Multipath Reduction (FM)

Push this switch to activate the multipath reduction portion of the Asymmetrical Charge-Coupled FM Detector.

Using the Noise and Multipath Reduction Switches

The following sections provide information on using the NOISE and MULTIPATH REDUCTION switches, and the Asymmetrical Charge-Coupled FM Detector circuit.

The circuit your Carver TX-11b uses to get you more listenable stereo than you've ever heard before is the Asymmetrical Charge-Coupled FM Detector™. The first part of this patented circuit is a charge-coupled delay line for detecting and reducing phase modulation in an oncoming signal. This phase distortion is multipath-induced, and can be compared to the ghosts you see when the TV signals suffer from it.

The second portion of the circuit is the Leading Edge Detector, another breakthrough derived from Bob Carver's ear/brain research (the source of Sonic Holography™, too). He found that all the noise-polluted L-R part of the FM stereo signal isn't necessary to make your senses hear stereo. When this part of the Asymmetrical Charge-Coupled FM Detector is engaged, the TX-11b uses only enough of the L-R signal to produce stereo music and programming, rejecting the rest.

Although the Asymmetrical Charge-Coupled FM Detector can't help noisy and distorted L+R components of a transmitted FM stereo signal, it can add up to 23 dB of signal-to-noise ratio (S/N), and make stereo signals as quiet as stations broadcast in mono. To further understand how the Asymmetrical Charge-Coupled FM Detector and various components of the transmitted FM signal interrelate, see Section 1 of the Appendix.

In FM mode, the lower two of the four switches (on the lower right-hand side of the TX-11b) engage the Asymmetrical Charge-Coupled Detector. The lower left switch engages the noise reduction circuitry; the lower right, the multipath reduction circuitry. Either one, or both may be engaged simultaneously.

Pushing just the MULTIPATH REDUCTION switch sets the circuit to reduce multipath and noise by approximately 15 dB, and optimizes the circuit for multipath reduction. Pressing the NOISE REDUCTION switch sets the circuit to reduce noise and multipath by approximately 10 dB. The NOISE REDUCTION switch will optimize the circuit for reducing noise. If both switches are engaged, there will be approximately 23 dB of noise and multipath reduction for received signal strength levels between 1 μ V and 20 μ V. In other words, very weak or distant stations.

Which switch you use depends on the problems with reception. Some stations will sound best if the NOISE REDUCTION is engaged; some with only the MULTIPATH REDUCTION switched in; some with both. It's important to remember that most stereo reception problems can be cleared up by using the MULTIPATH REDUCTION part of the circuit by itself. At least until you've had a chance to set-up an antenna system and experiment on a station-by-station basis, we suggest switching the MULTIPATH REDUCTION in and leave it that way. This will result in spectacular FM stereo reception in a great many areas, and for the majority of stations. However, if a station suffers from both noise and distortion, plus is very weak, use the NOISE REDUCTION, too.

If your TX-11b will be used with a commercial cable FM feed, it will probably be enough to use just the NOISE REDUCTION. Multipath interference is not really an issue with cable reception. If you're connected to cable, we suggest the NOISE REDUCTION be simply