

DENON

AM-FM TUNER

TU-767

OPERATING INSTRUCTIONS
MODE D'EMPLOI
BEDIENUNGSANLEITUNG

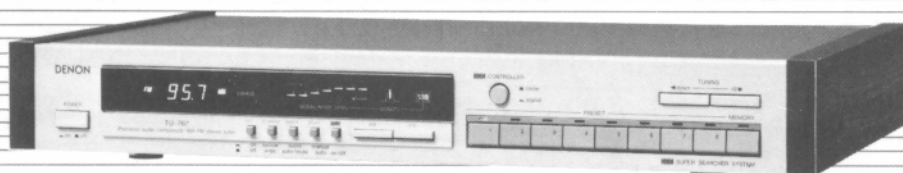

FOR ENGLISH READERS
POUR LES LECTEURS FRANCAIS
FÜR DEUTSCHE LESER

PAGE 1 ~ PAGE 15
PAGE 16 ~ PAGE 31
SEITE 32 ~ SEITE 46

In order to properly operate this tuner, please read this instruction manual before use. Please keep this for reference in the event you have further questions or in case of difficulties.

INTRODUCTION

TU-767 is a high level AM-FM tuner which has more than enough ability to cope with the combining of high grade as Hi-Fi equipment for audio and music fans.

This tuner is handy and offers good basic performance obtained only through strenuous research by DENON sound engineers who keep pursuing until satisfaction, then we are sure you will find entire contentment.

First of all read carefully the user's guide and use this tuner correctly and cautiously as instructed in the guide. At all costs, do not lose it as you might encounter trouble in understanding or operating.

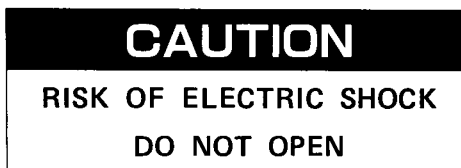
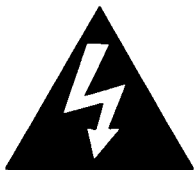

CAUTION: TO REDUCE THE RISK OF ELECTRIC SHOCK, DO NOT REMOVE COVER (OR BACK). NO USER SERVICEABLE PARTS INSIDE. REFER SERVICING TO QUALIFIED SERVICE PERSONNEL.



The lightning flash with arrowhead symbol within an equilateral triangle is intended to alert the user of the presence of uninsulated "dangerous voltage" within the product's enclosure that may be of sufficient magnitude to constitute a risk of electric shock to persons.



The exclamation point within an equilateral triangle is intended to alert the user of the presence of important operating and maintenance (servicing) instructions in the literature accompanying the appliance.

WARNING: TO PREVENT FIRE OR SHOCK HAZARD, DO NOT EXPOSE THIS APPLIANCE TO RAIN OR MOISTURE.

"SERIAL NO. _____"

PLEASE RECORD UNIT SERIAL NUMBER ATTACHED TO THE REAR OF THE CABINET FOR FUTURE REFERENCE"

– TABLE OF CONTENTS –

FEATURES	3
BEFORE USE	4
PRECAUTIONS	4
CONNECTIONS	5
CONTROLS AND THEIR DESCRIPTION	7
OPERATION	9
BEFORE USE	9
HOW TO RECEIVE FM AND AM BROADCASTS	10
FM BROADCAST RECEPTION USING THE SUPER SEARCH SYSTEM (SSS)	11
PRESETTING	12
RECEPTION OF PRESET AM/FM RADIO STATIONS	12
USE OF TIMER WITH TUNER	13
OPERATING PRINCIPLE OF THE SUPER SEARCH SYSTEM (SSS)	13
SPECIFICATIONS	14
TROUBLESHOOTING	15

The following items are provided in the TU-767 tuner cardboard case; after opening the case, ensure they are included.

- (1) Simplified T-type FM reception antenna (300-ohm) 1
- (2) Connection cord (output cord) 1
- (3) Instruction manual 1
- (4) FM ANT ADAPTER (for USA & CANADA) 1

FEATURES

There are many sources of music today. FM radio is lately gaining more popularity, with new FM broadcast stations inaugurating services. In addition, the problem of interference in FM is increasing. This model is a frequency synthesized tuner with a super searcher system (SSS) that COLUMBIA has newly developed for removing intermodulation interference. The TU-767 comes in a new design with additional presetting function for automatic tuning to 8 AM and FM stations.

FM MODULE

The FM module has a band suppression circuit in the RF input stage to eliminate undesirable incoming waves. The FM detector works with a quadrature wave detection system.

AM MODULE

A varactor diode which is equivalent to two series-connected diodes is used in the amplitude modulation (AM) section. A ceramic filter is used for intermediate frequency (IF). These component parts greatly reduce interfering signals. Further, since a newly developed loop antenna is employed, AM reception is hardly influenced by electric field noise.

AUDIO SYSTEM MODULE

The audio system module employs a PLL IC in the MPX demodulation circuit. This audio system makes its sound reproduction characteristic flat with the pilot subcarrier turned off. Also, the DC output circuit has a direct linkage to the audio amplifier. Thus, the system can reproduce quality sounds.

FREQUENCY SYNTHESIZING CONTROL

A local FM frequency and a local AM oscillation frequency which selected are compared with a reference frequency of 7.2 MHz supplied by the quartz oscillator. Therefore, highly precise and accurate tuning can be achieved.

AUTOMATIC TUNING SYSTEM

A broadcast program is automatically received by the wave reception circuit which fine tunes to the desired station.

PRESET CIRCUIT

Eight FM and eight AM stations can be memorized by a one-touch operation. A desired station can be recalled from the memory anytime by one-touch operation.

This memory data can be kept for approximately 5 years. In the presetting mode, the red LED lights to indicate FM and AM reception.

RECORDING LEVEL CHECK

Since 440 Hz oscillator monitoring for the recording level is built-in, a proper recording level can easily be determined before recording broadcast music.

LAST CHANNEL MEMORY

The condition immediately prior to power turn-off is memorized, regardless of FM or AM presetting, or manual or automatic tuning.

BEFORE USE

Note the following instructions prior to operation.

- **RELOCATION**

Be sure to disconnect the power plug and the cords connecting the tuner with another audio device. Otherwise the cords will be damaged.

- **RETAIN FOR FUTURE REFERENCE**

For the convenience of description, some of the illustrations contained herein are not exact.

PRECAUTIONS

PRECAUTIONS AGAINST HEAT

Do not locate the tuner in a location subject to direct sunlight or intense heat.

When the tuner is put in an audio rack, there sometimes may be an abnormal rise of temperature. Should such trouble emerge, take steps for effective ventilation.

WATER, DAMPNES, AND DUST ARE VERY HARMFUL

Do not locate the tuner in a location subject to high humidity or dust. Otherwise, the tuner may be damaged. Keep water off the tuner. The tuner will be damaged if water gets inside.

Do not place a vase or other water containers on the tuner casing.

CARE OF THE ELECTRIC CORD

Do not damage the electric cord. The use of a cord that has been damaged may cause shock hazards. When you remove the plug, do not pull the cord, but hold the plug.

IF THE TUNER IS NOT TO BE USED FOR AN EXTENDED PERIOD

If the tuner is not in use for an extended period, be sure to disconnect the power plug from the outlet.

KEEP METALLIC SUBSTANCES AWAY FROM THE SYSTEM

Metallic objects such as needles, hair pins, coins, etc. will cause shock or fire hazard if they get inside the unit.

INSECTICIDES AND CHEMICAL CLEANERS ARE HARMFUL

Insecticides, benzine, paint thinner, and other volatile substances will cause the cabinet to discolor and warp. Handle them with care. Use a piece of soft cloth to wipe the case. Never use strong cleaning agents.

DO NOT OPEN THE COVER

There are no user serviceable parts inside. Refer servicing to a qualified technician.

KEEP THE VENTILATION SLITS CLEAR

If the vent holes are blocked, the interior temperature will rise abnormally, damaging the tuner.

CONNECTIONS

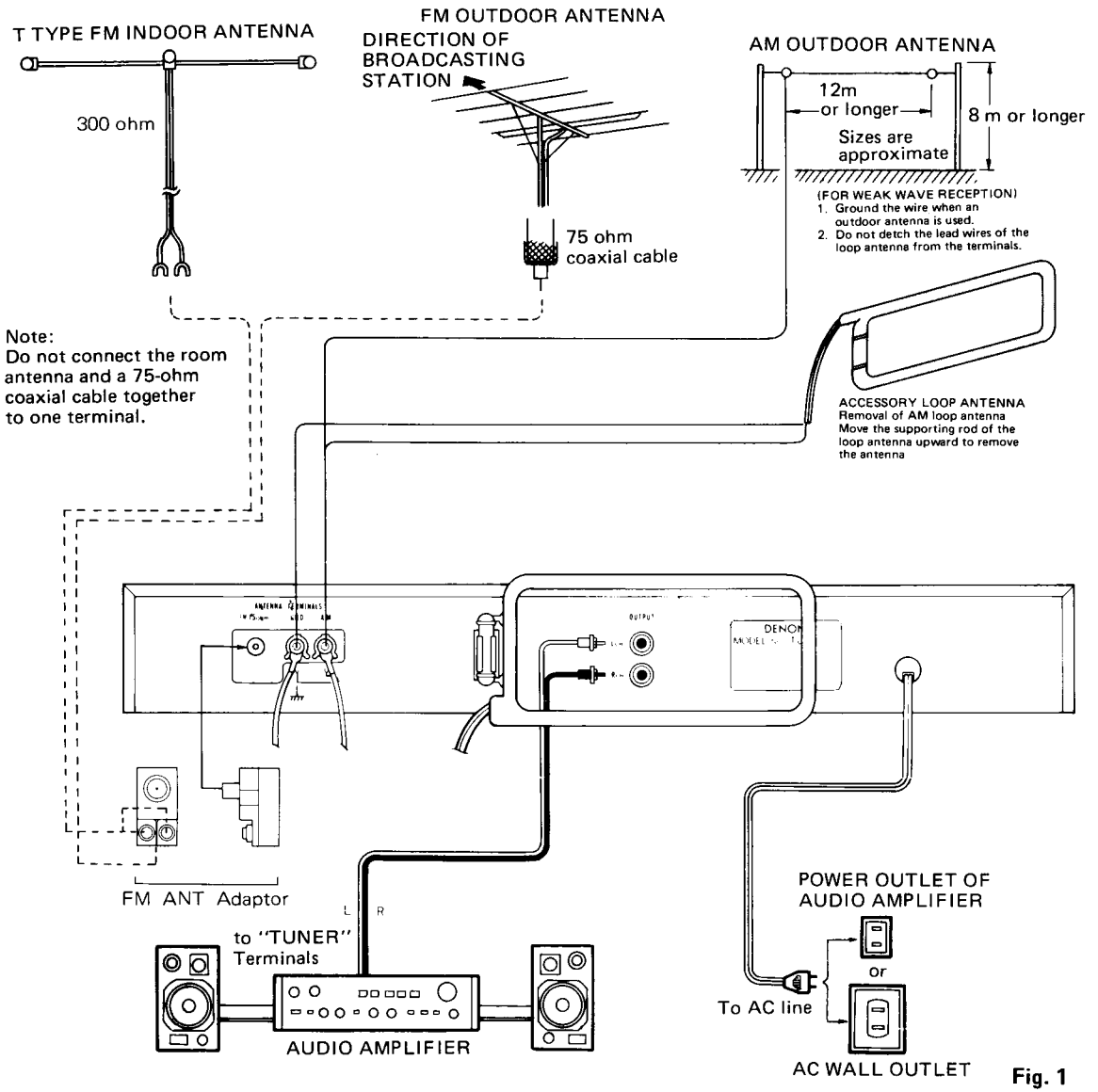

Note:
Do not connect the room antenna and a 75-ohm coaxial cable together to one terminal.

(FOR WEAK WAVE RECEPTION)
1. Ground the wire when an outdoor antenna is used.
2. Do not detach the lead wires of the loop antenna from the terminals.

ACCESSORY LOOP ANTENNA
Removal of AM loop antenna
Move the supporting rod of the loop antenna upward to remove the antenna

AC WALL OUTLET **Fig. 1**

PRECAUTIONS ON CONNECTIONS

Do not plug the cord into an AC outlet until all connections of the unit are completed.

● CONNECTION WITH AUDIO AMPLIFIER

Connect the pin cord (supplied) between the OUTPUT terminals of the tuner and the "tuner" input terminals of the audio amplifier. Be careful to connect the left (L) and right (R) channels of the output terminals to the corresponding left (L) and right (R) channels of the "tuner" input terminals. When the power cord of this unit is connected to the AC "SWITCHED" outlet of the audio amplifier, it is interlocked with the power switch of the audio amplifier, so that the power of the tuner is turned on/off if the power switch of the amplifier is turned on/off. (Set the volume control of the audio amplifier to minimum).

- Do not bundle or wind the pin plug and the power source cord together, and do not place the pin cord near the power transformer; otherwise, hum noise may result.
- Insert the plugs into the corresponding jacks firmly because incomplete connections cause electric field noise.

ANTENNA INSTALLATION

● T TYPE FM INDOOR ANTENNA

The accessory T type indoor antenna (75 ohm) can be used inside wooden houses when FM stations are local and strong signals can be received. While receiving an FM program, extend the horizontal part of the antenna. Orient the T-shaped part for optimal reception and mount the antenna on the wall or ceiling.

* In general, FM indoor antennas might not consistently assure stable reception, due to environmental changes. Use an FM indoor antenna temporarily until an outdoor antenna is installed.

● FM OUTDOOR ANTENNA CONNECTION (Fig. 2)

75 ohm coaxial cable (3C-2V, 5C-2V) is preferable to obtain better performance of the tuner.

* Contact your local dealer for details on selection and installation of the FM outdoor antenna.

* When a 300 ohm FM antenna is connected by a 75 ohm coaxial cable, a matching transformer is required.

● AM ANTENNA CONNECTION (Fig. 3)

Since the model is provided with a high performance AM loop antenna on the back panel, this accessory antenna can effectively be used for optimal reception in places where broadcasting stations are located nearby and relatively strong signals are received with low noise.

Orient the loop antenna horizontally to obtain optimal reception.

In places where strong, clear signals are not received due to particular location and/or environmental conditions, connect an insulated wire to the AM antenna terminals and attach it to the wall. In places where broadcasting stations are located too far away and only weak signals are received, or where signals are blocked by obstacles, install an AM outdoor antenna.

* Even if an AM outdoor antenna is installed, do not detach the AM loop antenna.

GROUNDING

If there is much noise during reception, it is recommended that a grounding wire be used.

Connect a thick insulated wire to the "GND" terminal, and wind the unconnected bare end around a metal water pipe, a grounding rod, or a grounded copper plate.

* Never connect grounding the wire to a gas pipe. This could cause fire or explosion.

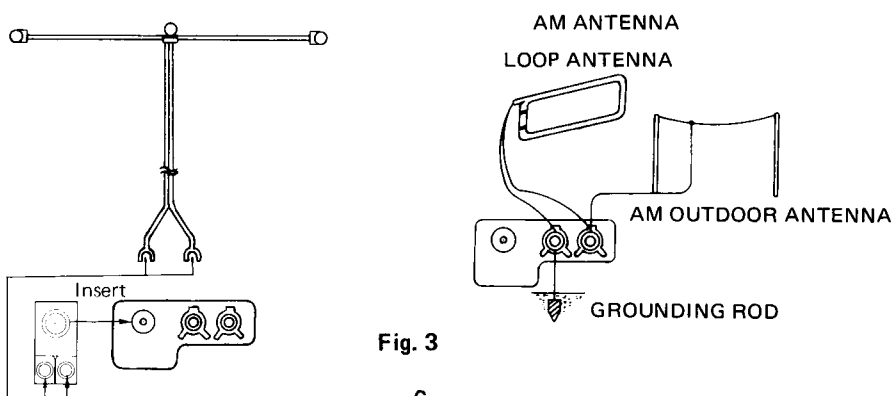
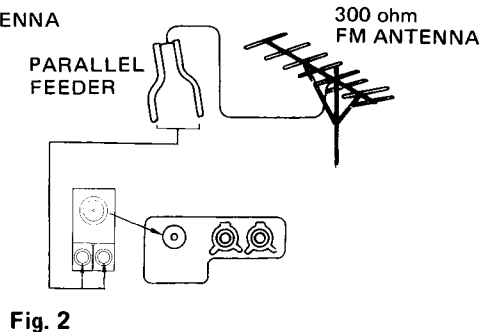
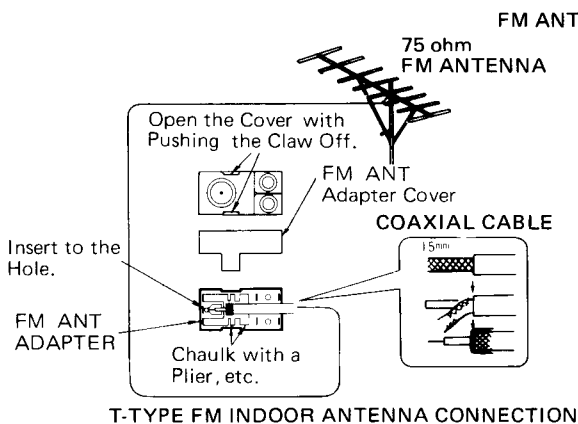

CONTROLS AND THEIR DESCRIPTION

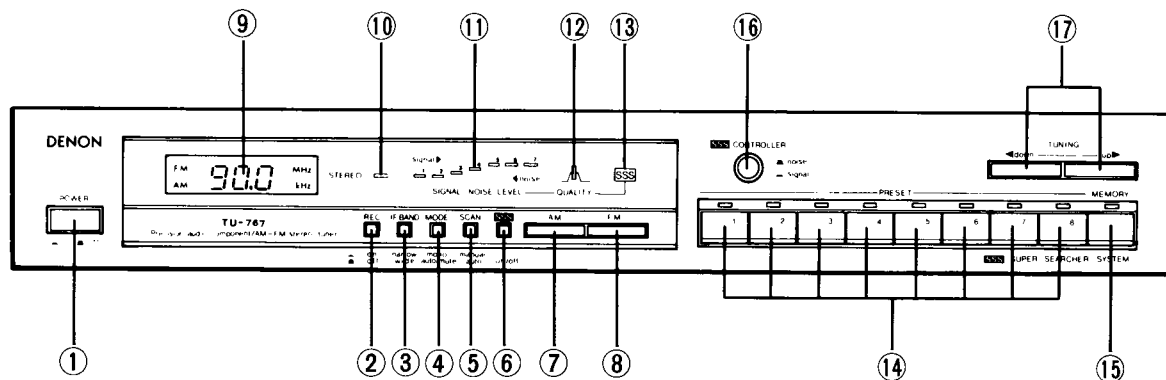

- 1 POWER (Power on/standby Switch)** Note: The power switch contains an ON/OFF indicator (except in models exported to Europe)
Set the power switch to "ON" to supply power; the LED indicator lights.
Two to three seconds after the power is turned "on", the tuner operates normally. When the power switch is set to "Standby", the power is shut off.
- 2 REC (Recording Level Switch)**
Set the recording level switch to "ON" to drive the built-in oscillator which checks FM reception. The oscillator continuously supplies signals of 440 Hz to the right (R) and left (L) output terminals. For AM broadcasting, the oscillator does not operate and these signals are not generated.
The signal tone level is set to an amplitude which is equivalent to 50% of modulation, that is, -6 dB (-11.5 dB for West Germany) at the time of 100% of FM broadcasting modulation. Set the recording level of the tape deck meter or indicator to 0 - 2 dB. (This setting value may vary from the performance of your deck. Please refer to "Operating Instructions of Tape Deck" of further details.)
This signal tone can be utilized for checking the balance and phase of the right and left channels of the speaker system.
- 3 IF BAND (IF Band Selector Switch)**
This selector sets either the wide or narrow band to effectively pick up the signals of intermediate frequencies. If the desired station fades into another station, shift the switch to NARROW, and selectivity is improved, and reception will be free from interference. If the desired station is not being interfered with set the selector to WIDE. With the selector set to WIDE, you can enjoy quality reception, since the radio frequency is concentrated. If the selector switch is at WIDE, reception may sometimes be difficult if the station has a low output or if the adjacent station has a larger output than the one you are receiving.
- 4 MODE (Mode Switch)**
 - auto/mute:
Receive an FM radio program in this position.
According to the mode of the program, the reception can be automatically switched to the monaural or automatic mode. When an FM stereo radio program is received, the stereo indicator automatically goes on. Noise generated when tuning from station to station can be eliminated with the muting circuit at the "auto/mute" position.
 - ▲ mono:
An FM radio programs are received in monaural mode, regardless of stereo or monaural broadcasting programs. If there is much noise at the "auto/mute" position due to a weak sound signal, set to this "mono" position. This mode switch is not related to AM broadcasting.
- 5 SCAN (Tuning Mode Select Switch)**
 - auto: Set to "auto" for automatic tuning.
 - ▲ manual: Set to "manual" for manual tuning.

6 SSS ON/OFF (See Page 13 for Details Regarding the Super Searcher System – SSS)

This is the super searcher system on/off switch. Pressing this pushbutton turns the super searcher system on or off. When the super searcher system is on, the SSS indicator lights. When the super searcher system is off, the indicator is off. Pressing POWER switch, FM/AM selector switch, TUNING buttons or PRESET switch will automatically turn off the super searcher system. To use the system after pressing any one of the above buttons, you must press the SSS button once more.

While the super searcher system is on, muting is off. Therefore, when the system is on, the noise picked up in the frequency range of some selected stations stand out.

7 AM: Press this button for AM reception.

8 FM: Press this button for FM reception.



9 DIGITAL FREQUENCY INDICATOR

Reception frequencies are digitally indicated. The FM frequency unit is MHz; the AM frequency unit is kHz.

10 STEREO (Stereo Indicator)

When the MODE switch is set to the "auto/mute" position and a stereo program is received, the stereo indicator lights. When the MODE switch is set to the "mono" position, the stereo indicator does not light.

11 SIGNAL/NOISE LEVEL

This is an signal strength and noise level indicator. Setting the SSS CONTROLLER switch to SIGNAL () will cause the LEDs to light. The number of LEDs lit indicates signal strength. In this mode LEDs light green. Setting the SSS CONTROLLER switch to NOISE () will again cause the LEDs to light. Only in this case, they indicate the level of intermodulation interference. In this mode, LEDs light red. When the noise level lessens after the super search system is set on, the number of red LEDs decreases. If no station is received, the indicated noise level is maximum.

12 QUALITY (Quality Indicator)

When S/N ratio is over 50 dB at FM reception, the reception quality indicator LED lights green. In case of interference, even with the signal indicator on, or when a distant station is tuned in with much noise, the reception quality indicator does not light. In such a case, adjust the tuner, using SSS CONTROLLER to remove the interference, relocate the antenna, or adjust the antenna setting direction.

13 SSS (Super Searcher System Indicator)

This indicator lights when the SSS ON/OFF switch is turned on.

14 PRESET CHANNEL 1 – 8 (Station Presetting Buttons)

These buttons are used for storing broadcast frequencies. One FM or AM station can be memorized for each button. When the preset channel buttons are in operation, an indicator (red LED) lights. When radio stations are memorized with these buttons, a desired station can be easily tuned with out pressing the tuning buttons.

15 MEMORY (Memory Button)

This switch is used to register the desired radio station to one of the preset buttons memory. When pressing this button, the memory switch indicator lights for approximately 10 seconds. During this interval, the desired station is registered in the memory. Pressing one station preset button will light the corresponding station preset indicator and turn off the memory switch indicator.

16 SSS CONTROLLER (Super Searcher System Control Knob)

This knob is a push push type. When out (■ noise), the SIGNAL/NOISE LEVEL indicator lights red and displays the level of noise. When it is pushed in (▾ signal), the indicator lights green, and gives the signal level. Turning the knob while the button is out (■ noise) and with SSS switch ON, will change the setting of the band suppression circuit which works to eliminate interfering stations. Turning to the left (⤴) will change the setting toward 87.5 MHz and to the right (⤵) toward 108 MHz.

NOTE:

The band suppression circuit does not eliminate intermodulation interference when the SSS switch is OFF.

17 TUNING (Tuning Buttons)

Use these two buttons for either manual tuning or automatic tuning.

- ▶ up When this button is pressed, the frequency will change to a higher frequency
- ◀ down When this button is pressed, the frequency will change to a lower frequency

* Manual Tuning

In FM mode, tuning indicator moves in 50 kHz (100 kHz for U.S.A.) steps. In AM, indicator moves in 9 kHz (10 kHz for U.S.A.) steps. If these buttons are pressed for more than 2 seconds, the indicator moves up quickly and continuously until released.

* Automatic Tuning

For example, when the "up" button is pressed once, the frequency indicator moves up band until a broadcast sound signal is detected and received. If the button is pressed again, the counter again moves up band until the next broadcasting station is turned. If the button is again pressed, the counter moves to the upper limit 108.00 MHz for FM, 1611 kHz (for Europe) 1710 kHz (for U.S.A.) for AM.

If no more signals are detected, the counter is then automatically moves down to the nearest broadcast sound signal.

(When the "down" button is pressed, the counter travels down the band until a signal is detected or until the lower limit 87.5 Mhz for FM, 522 kHz (for Europe) 520 kHz (for U.S.A.) for AM. When the counter moves down to the lower limit, the counter then automatically moves up the band again.)

While the button is continuously pressed, broadcast signals cannot be tuned; the counter continuously travels up or down the band. Automatic tuning is only provided for commercially available radio waves; a sudden, strong noise may disturb automatic tuning.

When a weak signal is to be received, perform manual tuning.

OPERATION INSTRUCTIONS

BEFORE USE

CHECKING CONNECTIONS

- Check all the connections by referring to connection diagram (Fig. 1).
- Check that the right (R) and left (L) channels of the speakers are connected to the corresponding right (R) and left (L) plugs, and check that polarities (positive and negative) are correctly matched.
- Check that the right (R) and left (L) pins are correctly inserted to the corresponding jacks.
- Check that all the cords are firmly connected.

* Turn on the power with the POWER switch after checking all the connections.

CHECKING ANTENNA

1. Do not incorrectly connect the AM loop antenna. If you are not sure how to connect the AM loop antenna, refer to page 5 and page 6.
2. Use of AM loop antenna: Keep the AM loop antenna away from the main body. If the antenna contacts the metal body, reception sensitivity is degraded, thus resulting in unclear reproduction.

HOW TO RECEIVE FM AND AM BROADCASTS

FOLLOW THE NUMBERED SEQUENCE.

○ □ FM RECEPTION
● ■ AM RECEPTION

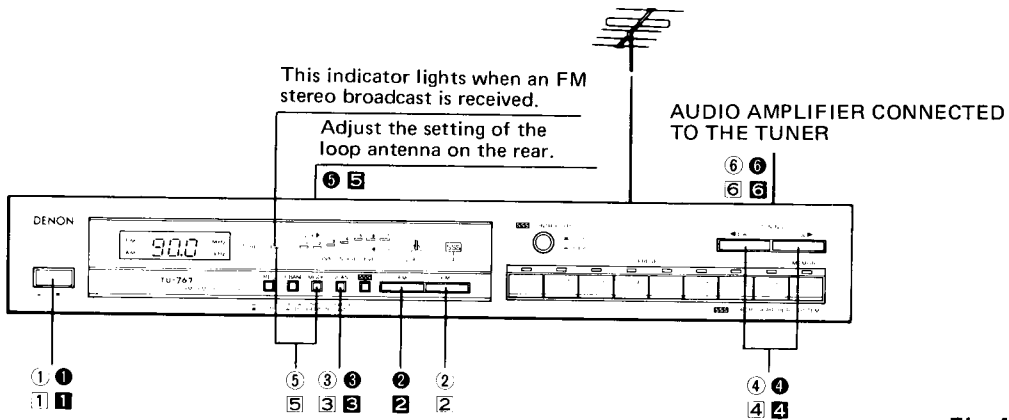

Fig. 4

HOW TO RECEIVE FM BROADCAST RECEPTION

AUTOMATIC TUNING

- ① Turn POWER switch ON ().
- ② Press FM button switch.
- ③ Shift SCAN switch to AUTO ().
- ④ Press either TUNING (up) or (down) button, and the tuning indicator reading stops whenever a radio station is found. To continue searching, press either button again.
- ⑤ STEREO indicator lights when a stereo broadcast is received with the MODE button set to AUTO MUTE (). If up or down scale tuning does not pick up the desired station, tune with the tuning knob.
- ⑥ The tone and volume are adjusted by amplifier.

MANUAL TUNING

- ① Turn POWER switch on ().
- ② Press FM switch.
- ③ Set SCAN switch to MANUAL ().
- ④ Press either TUNING (up) or (down) button while watching the indicator to find the desired station. Set the indicator as near the desired station as possible with the button. Fine tune with the TUNING knob.
- ⑤ The stereo indicator lights as long as a stereo broadcast is received and the MODE button is set to AUTO MODE (). If the signal indicator does not light) even if the tuning indicator is at the desired station, check the FM antenna. For details see pages 5 to 6.
- ⑥ The tone and volume are adjusted by the amplifier.

NOTE:

When using the tuner near a TV set, noise may occur in AM reception. It is recommended to keep the audio system as far away from the TV as possible.

HOW TO RECEIVE AM BROADCASTS

AUTOMATIC TUNING

- ① Turn POWER switch ON ().
- ② Press AM button switch.
- ③ Set SCAN switch to AUTO ().
- ④ Press either TUNING button (up) or (down). The indicator stops when a radio station is found. To receive another station, press the button again.
- ⑤ Adjust the setting of the loop antenna on the rear for best reception. If the tuning indicator does not stop, manual tune.
- ⑥ The fone and volume are adjusted by the amplifier.

MANUAL TUNING

- ① Turn POWER switch ON ().
- ② Press AM button.
- ③ Set SCAN switch to MANUAL ().
- ④ Press TUNING button (up) or (down) to pick-up the desired radio station. Pressing the TUNING button to get as near the desired station as possible. Fine tune with the tuning knob.
- ⑤ Adjust the loop antenna on the rear for best reception. If the signal indicator does not light even if the tuning indicator is at the desired station, adjust the loop antenna. For details, see pages 5 to 6.
- ⑥ The tone and volume are adjusted by the amplifier.

FM BROADCAST RECEPTION USING THE SUPER SEARCHER SYSTEM (SSS)

The super searcher system is for FM reception only.

If there are more than two stations on the same band having large outputs, reception of any of these stations is accompanied by intermodulation interference. This interference produces a distorted radio signal. No matter how adverse the reception conditions may be, you can enjoy quality FM broadcast reception using the super searcher system. Follow the procedure given below to properly operate the super searcher system. When the QUALITY indicator lights, intermodulation interference is detected, even if SIGNAL indicator is lighting green. In this case, NOISE LEVEL indicator (red) is on, and noise is produced.

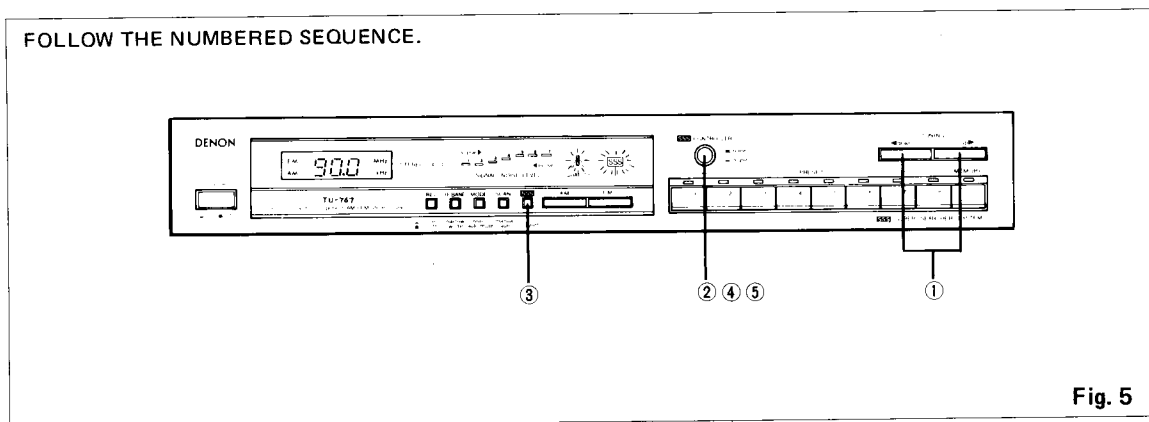

See page 10 covering "How to receive FM broadcasts". The procedure for working the super searcher system is the same as in paragraph (1) – (3). The step in paragraph (3) below is applicable commonly in the automatic and manual modes.

- ① Set the tuning indicator to the desired radio station.
- 2 Press SSS CONTROLLER switch to (■) to set it to NOISE. If the station reception has intermodulation interference or any other interference, the number of red LED proportional to the noise level will light.
- ③ Pressing SSS button will light SSS indicator, indicating that the band suppression circuit is on.
- ④ While observing the noise level indication, gradually turn SSS CONTROLLER switch clockwise to search the position where the noise level is minimum. With SSS CONTROLLER switch set to the minimum noise level, clear sounds are reproduced while, at the same time, QUALITY indicator lights. This is because the interference has been removed by the super search system.
- ⑤ When these steps are finished, the adjustment switch is finished. Press SSS CONTROLLER switch once more to set the switch to SIGNAL (■).

NOTES:

1. During noise level adjustment, there are sometimes two points on the band where the noise levels appear to be minimal with one, being slightly lower. Set SSS CONTROLLER knob to the lowest position.
2. If the NOISE indicator lights due to interference from a neighbouring station, set the IF BAND selector to NARROW. With this switch set to NARROW, tuning is accomplished with good selectivity.
3. Sometimes noise level cannot be suppressed with the adjustment specified in paragraph (4). This is because the intermodulation interference is intense. In such a case, it is necessary to use the super search system in combination with a commercially available attenuator. In this way, the input noise level can be lessened, and the intermodulation interference can be removed effectively.
4. The band suppression circuit is designed to eliminate undesired waves over a narrow band. If the noise level is set to maximum by accident, it is impossible to receive the desired station.

PRESETTING (Refer to Fig. 6)

After completing presetting, just depress one of the preset buttons to tune to a desired station. Follow the presetting procedures below:

- ① Set the POWER switch to "ON".
- ② Select the band of the desired station to be preset and set the SELECT button to either "AM" or "FM".
- ③ Tune to the desired radio station with the tuning button.
- ④ The MEMORY LEDs light for about 10 seconds after the MEMORY button is pressed. During this time, press one of the eight PRESET CHANNEL buttons.
- ⑤ The indicator for a depressed preset button goes on and the indicated frequency is stored in the corresponding channel. Eight-channel preset function can memorize up to eight stations for FM or AM in the preset button.

NOTE:

If the preset button is inoperative during the illumination of "MEMORY" within the indicator window, depress the MEMORY and preset buttons again.

- * This model has a last channel memory system and retains it immediately before the power is turned off, regardless of the selection of FM or AM, preset mode, and manual or automatic tuning.
- * The TU-767 is designed to store stations that have been previously registered in the memory and retain them, even if the tuner is deenergized temporarily. The memory can hold registered data for approximately about 5 years after shipment from the factory. If replacement is necessary, contact our service department.

RECEPTION OF PRESET AM/FM RADIO STATIONS (Refer to Fig. 7)

- ① Set the POWER switch to "ON". The frequency immediately before the power switch is turned off is indicated in the indicator window.
- ② Depress the preset channel button for storing the frequency of the desired station.
- ③ Press the SELECT button to either "AM" or "FM" according to the frequency specified in procedure 2.
- ④ Adjust the volume and tone by the amplifier.

FOLLOW THE PROCEDURES IN THE INDICATED ORDER.

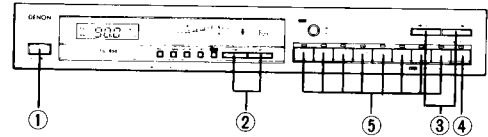

Fig. 6

FOLLOW THE PROCEDURES IN THE INDICATED ORDER

③ AUDIO AMPLIFIER CONNECTED TO THE TUNER

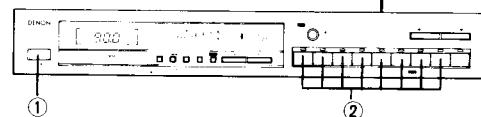
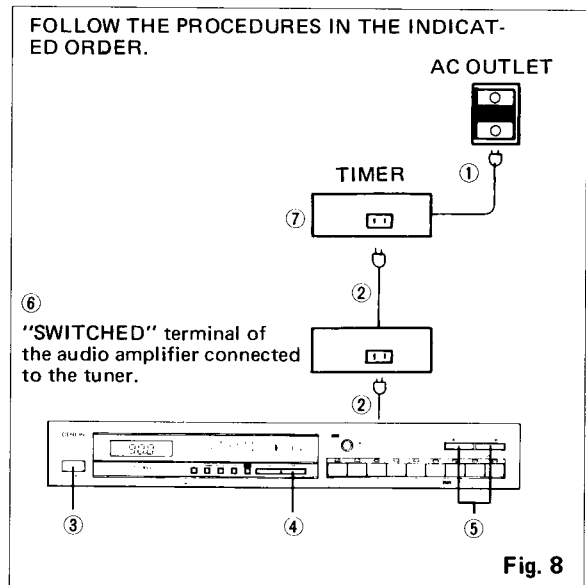

Fig. 7

USE OF TIMER WITH TUNER (Refer to Fig. 8)

Example: For Listening to an FM Radio Program at a Predetermined Time.

- ① Connect the timer power cord the outlet to turn on the timer (see the timer instruction manual).
- ② Insert the power source cord of the tuner into either the "SWITCHED" terminal of the audio amplifier connected to the tuner or the outlet of the timer.
- ③ Set the POWER switch to "ON".
- ④ Push the FM button.
- ⑤ Depress the TUNING button to tune to a desired station. (Please tune in the radio program for optimal reception. Refer to "For FM Reception" on page 8 for further details.)
- ⑥ Adjust the volume and tone of the audio amplifier as needed.
- ⑦ Set the timer to the desired start time.



OPERATING PRINCIPLE OF THE SUPER SEARCHER SYSTEM (SSS)

When radio waves of more than two stations on one band enter the front end, a false radio wave will emerge at a point away from either signal (provided, the number of stations concerned is two in this case). This false wave causes intermodulation interference. If reception is made with a certain station having a signal with the same frequency of the false radio wave, reception is accompanied by intermodulation interference noise and suffers from various other interference.

Fig. 9 shows how intermodulation interference occurs, and how to effect interference-free reception. Referring to this figure, two false radio waves D1 and D2 emerge at the respective points, each off one of two radio wave frequencies of stations (A and B). These false waves cause intermodulation interference to the reception with station C. If the frequency of the radio wave from station C is the same as the frequency of the false radio wave D1, it is normally impossible to isolate the false wave. But with the TU-767, the band suppression circuit installed in the stage just before the front end, removes false radio wave D1 and D2 from either station A or B. Therefore, any audio system employing this Model is assured of quality reception free from intermodulation interference.

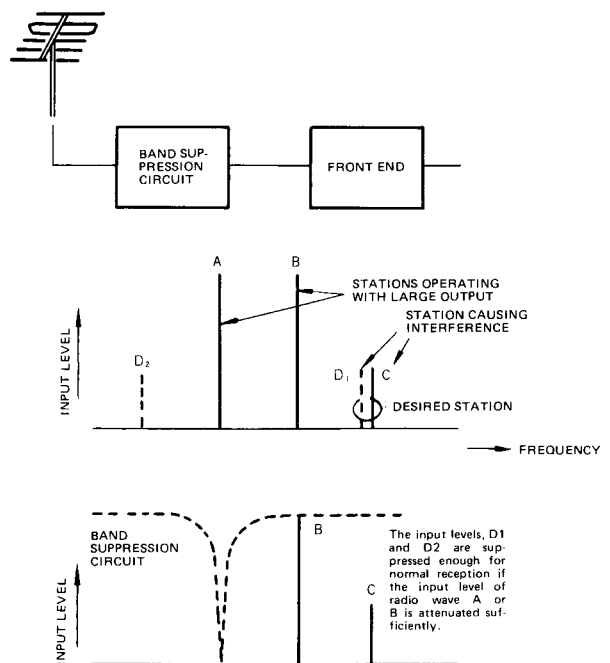

Fig. 9

SPECIFICATIONS

FM SECTION

Frequency Range:	87.5 ~ 108 MHz		
Antenna Terminals:	75 ohm unbalanced		
Practical Sensitivity:	0.9 μ V (10.3 dBf)		
S/N 50 dB Sensitivity:	St.: 15.8 μ V (35.2 dBf)		
	Mo.: 1.5 μ V (14.2 dBf)		
	0 dBf at 10^{-15} W (new IHF Standard)		
Image Interference Ratio:	90 dB		
IF Interference Ratio:	100 dB		
AM Suppression Ratio:	65 dB		
Effective Selectivity:	Wide = 50 dB		
	Narrow = 60 dB (\pm 300 kHz)		
Capture Ratio:	1.0 dB		
Frequency Characteristics:	20 Hz to 15 kHz $^{+0.2}_{-1.5}$ dB		
Signal-to-noise Ratio:	Monaural: 88 dB		
	Stereo: 82 dB		
Total Harmonic Distortion:		Monaural	Stereo
		(at 100% modulation)	(at 90% modulation)
	1 kHz	0.03%	0.04%
Stereo Separation:	1 kHz	57 dB	
Muting Operating Level:	20 dB		
Output Level (at 100% modulation):	0.6 V		

AM SECTION (MW or LW)

MEDIUM WAVE

Frequency Range:	522 ~ 1611 kHz (for Europe), 520 ~ 1710 kHz (for U.S.A.)		
Antenna Terminal:	With Loop Antenna		
Usable Sensitivity:	18 μ V		
Selectivity:	55 dB		
Image Interference Ratio:	45 dB		
Signal-to-noise Ratio:	55 dB		
Total Harmonic Distortion:	0.3%		
Output Level (at 30% modulation):	0.2 V		

or LONG WAVE

Frequency Range:	153 ~ 360 kHz		
Usable Sensitivity:	40 μ V		
Selectivity:	50 dB		
Image Rejection:	60 dB		
Signal-to-noise Ratio:	50 dB		

LEVEL CHECKING SIGNAL

Frequency:	440 Hz
Output Level:	0.3 V

Electric Field Strength Indication: by seven LED's (Green)

OTHERS

Power Supply:	AC 120 V/60 Hz (for U.S.A. and Canada)
	AC 220 V/50 Hz (for Europe)
	AC 240 V/50 Hz (for England and Australia)
Power Requirement:	11 W

Dimensions:	464 mm (18.3") W x 66 mm (2.6") H x 281 mm (11.1") D (with Wood Board)
	434 mm (17.1") W x 66 mm (2.6") H x 281 mm (11.1") D (without Wood Board)
Net Weight:	3.9 kg (8.58 lbs) (with Wood Board)
	3.6 kg (7.94 lbs) (without Wood Board)

Design and specifications subject to change without notice.

TROUBLESHOOTING

Make sure that the problem is really a problem.

1. Have all connections been properly made?
2. Have you followed all the operating instructions correctly?
3. Check if the speakers and the amplifier are working properly?

When your set does not seem to be operating as it should, first check the points in the following table. If you still cannot locate the problem after going through all points, the trouble may in fact lie with the tuner itself, so please contact your local DENON dealer.

CAUTION

A lithium cell is used in the unit for maintaining preset memory. If preset memory does not operate correctly, contact the dealer where you purchased the unit.

Symptom	Cause	Remedy
Radio program is not received when preset button is depressed	<ul style="list-style-type: none"> • The frequency of the radio station cannot be preset in this channel. 	<ul style="list-style-type: none"> • Tune to a receivable radio station and preset its frequency in the channel.
The stereo indicator is erratically illuminated.	<ul style="list-style-type: none"> • The input wave is weak. 	<ul style="list-style-type: none"> • Orient the antenna. • Install an FM outdoor antenna.
Noise from speakers.	<ul style="list-style-type: none"> • The input wave is weak. • Ignition noise interferes with wave reception. • Other electrical equipment interferes with wave reception and reproduction. • Cord connections are defective. 	<ul style="list-style-type: none"> • Install an outdoor antenna. • Orient AM loop antenna when AM broadcasts are being received. • Keep the antenna away from the street. • Tune to the station again. • Turn off other electrical equipment. • Check all the connections.
Intermodulation interference cannot be removed with automatic tuning on.	<ul style="list-style-type: none"> • The input level of the radio wave from the station is low. 	<ul style="list-style-type: none"> • Adjust the antenna direction. • Install an outdoor antenna.
Removal of intermodulation and interference is available only up to the channel prior to that of the desired station when automatic tuning is under way.	<ul style="list-style-type: none"> • Tuning is being made with a high-level radio wave from a nearby station. 	<ul style="list-style-type: none"> • Tuning should be carried out in the manual mode.

SAFETY INSTRUCTIONS

1. Read Instructions – All the safety and operating instructions should be read before the appliance is operated.
2. Retain Instructions – The safety and operating instructions should be retained for future reference.
3. Heed Warnings – All warnings on the appliance and in the operating instructions should be adhered to.
4. Follow Instructions – All operating and use instructions should be followed.
5. Water and Moisture – The appliance should not be used near water – for example, near a bathtub, washbowl, kitchen sink, laundry tub, in a wet basement, or near a swimming pool, etc.
6. Ventilation – The appliance should be situated so that its location or position does not interfere with its proper ventilation. For example, the appliance should not be situated on a bed, sofa, rug, or similar surface that may block the ventilation openings; or, placed in a built-in installation, such as a bookcase or cabinet that may impede the flow of air through the ventilation openings.
7. Heat – The appliance should be situated away from heat sources such as radiators, heat registers, stoves, or other appliances (including amplifiers) that produce heat.
8. Power Sources – The appliance should be connected to a power supply only of the type described in the operating instructions or as marked on the appliance.
9. Power-Cord Protection – Power-supply cords should be routed so that they are not likely to be walked on or pinched by items placed upon or against them, paying particular attention to cords at plugs, convenience receptacles, and the point where they exit from the appliance.
10. Cleaning – The appliance should be cleaned only as recommended by the manufacturer.
11. Power Lines – An outdoor antenna should be located away from power lines.
12. Outdoor Antenna Grounding – If an outside antenna is connected to the receiver, be sure the antenna system is grounded so as to provide some protection against voltage surges and built up static charges. Section 810 of the National Electrical Code, ANSI / NFPA No. 70-1981, provides information with respect to proper grounding of the mast and supporting structure, grounding of the lead-in wire to an antenna discharge unit, size of grounding conductors, location of antenna-discharge unit, connection to grounding electrodes, and requirements for the grounding electrode. See Figure 1.

Figure 1. Example of antenna grounding as per National Electrical Code instructions

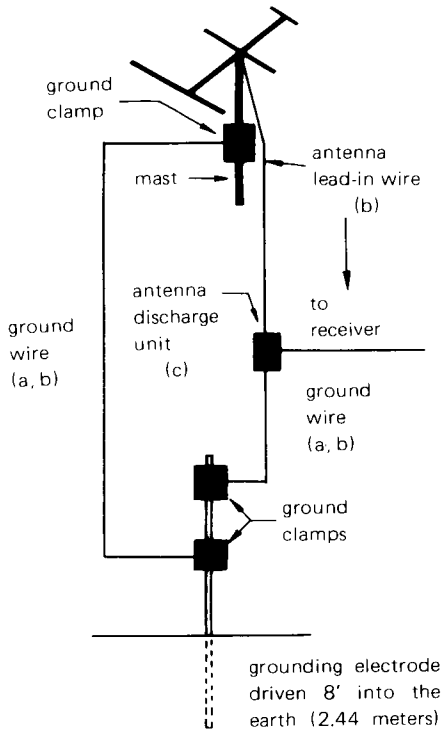

- a. Use No. 10 AWG (5.3 mm²) copper, No. 8 AWG (8.4 mm²) aluminum, No. 17 AWG (1.0 mm²) copper-clad steel or bronze wire, or larger, as ground wire.
- b. Secure antenna lead-in and ground wires to house with stand-off insulators spaced from 4 feet (1.22 m) to 6 feet (1.83 m) apart.
- c. Mount antenna discharge unit as close as possible to where lead-in enters house.

13. Nonuse Periods – The power cord of the appliance should be unplugged from the outlet when left unused for a long period of time.
14. Object and Liquid Entry – Care should be taken so that objects do not fall liquids are not spilled into the enclosure through openings.
15. Damage Requiring Service – The appliance should be serviced by qualified service personnel when:
 - A. The power-supply cord or the plug has been damaged; or
 - B. Objects have fallen, or liquid has been spilled into the appliance; or
 - C. The appliance has been exposed to rain; or
 - D. The appliance does not appear to operate normally or exhibits a marked change in performance; or
 - E. The appliance has been dropped, or the enclosure damaged.
16. Servicing – The user should not attempt to service the appliance beyond that described in the operating instructions. All other servicing should be referred to qualified service personnel.

NIPPON COLUMBIA COMPANY, LTD.

No. 14-14, AKASAKA 4-CHOME, MINATO-KU, TOKYO, JAPAN

Telephone: Tokyo (584) 8111

Cable: NIPPONCOLUMBIA TOKYO Telex: JAPANOLA J22591