

Ref. No.	Value (F)	R/S Part No.	Voltage (V)	Tolerance (%)	Material
C301	1500P		50	±10	Polystyrene
C302	1μ		50	+75 -10	Electrolytic
C303	10μ		25	+50 -10	Electrolytic
C304	47μ		16	+50 -10	Electrolytic
C305	1μ		50	+75 -10	Electrolytic
C306	1μ		50	+75 -10	Electrolytic
C307	0.012μ		50	±10	Polyester
C308	0.012μ		50	±10	Polyester
C309	0.22μ		50	±20	Electrolytic
C310	0.47μ		50	±20	Electrolytic
C311	0.22μ		50	±20	Electrolytic
C312	Not Used				
C313	0.047μ		50	±10	Polyester
C314	*0.033μ		50	±10	Polyester
C315	*0.033μ		50	±10	Polyester
C316	0.1μ		50	+75 -10	Electrolytic
C317	0.1μ		50	+75 -10	Electrolytic
C318	220P	CF-1503	50	±10	Ceramic
C319	220P	CF-1503	50	±10	Ceramic
C320	1μ		50	+75 -10	Electrolytic
C321	1μ		50	+75 -10	Electrolytic
C322	10μ		16	+50 -10	Electrolytic
C323	270P	CF-1503	50	±10	Ceramic
C324	Not Used				
C325	47μ		16	+50 -10	Electrolytic
C401	10P		50	±0.5PF	Ceramic
C402	360P	CF-1516	50	±10	Ceramic
C403	10μ		16	+50 -10	Electrolytic
C404	47P	CF-1366	50	±10	Ceramic
C405	10μ		16	+50 -10	Electrolytic
C406	0.01μ	CF-1746	25	+80 -20	Ceramic
C407	0.01μ	CF-1746	25	+80 -20	Ceramic
C408	0.01μ	CF-1746	25	+80 -20	Ceramic
C409	0.01μ	CF-1699	50	±10	Ceramic
C410	0.1μ		50	+75 -10	Electrolytic
C411	22μ		10	+50 -10	Electrolytic
C412	0.01μ	CF-1746	25	+80 -20	Ceramic
C413	0.04μ	CF-1786	25	+80 -20	Ceramic

Ref. No.	Value (F)	R/S Part No.	Voltage (V)	Tolerance (%)	Material
C414	4.7μ		25	+75 -10	Electrolytic
C415	3.3μ		50	+75 -10	Electrolytic
C416	1000P	CF-1553	50	±10	Ceramic
C417	0.022μ		25	+80 -20	Ceramic
C418	0.04μ	CF-1786	25	+80 -20	Ceramic
C419	1μ		50	+75 -10	Electrolytic
C420	1μ		50	+75 -10	Electrolytic
C421	0.018μ		25		
C422	47μ		16	+50 -10	Electrolytic
C451	0.01μ	CF-1746	25	+80 -20	Ceramic
C701	0.01μ	CF-1746	25	+80 -20	Ceramic
C702	22μ		16	+50 -10	Electrolytic
C703	10μ		16	+50 -10	Electrolytic
C704	22μ		16	+50 -10	Electrolytic
C705	10μ		16	+50 -10	Electrolytic
C801	0.01μ	CF-1746	25	+80 -20	Ceramic
C802	1000μ		25	+50 -10	Electrolytic
C803	220μ		25	+50 -10	Electrolytic
C804	47μ		25	+50 -10	Electrolytic
C805	220μ		25	+50 -10	Electrolytic
C806	470μ		16	+50 -10	Electrolytic
C807	Not Used				
C808	Not Used				
C809	33μ		16	+50 -10	Electrolytic
C810	220μ		16	+50 -10	Electrolytic
C811	47μ		16	+50 -10	Electrolytic
*C851	0.022μ		250	±20	Polyester
*C852	0.022μ		250	±20	Polyester

* C851, C852: for European and Australian models only

CERAMIC FILTERS			
Ref. No.	Description	R/S Part No.	Mfr's Part No.
CF201	For FM 10.7ML-M8	C-0926	35300026
CF202	For FM 10.7ML-M8	C-0926	35300026
CF203	For FM 10.7ML-M8	C-0926	35300026
CF204	For FM 10.7ML-M8	C-0926	35300026
CF401	For AM SF455B	C-0869	35300023

*0.015μ for European and Australian models

COILS & TRANSFORMERS

Ref. No.	Description	R/S Part No.	Mfr's Part No.
L101	FM Ant. Coil 129A	CA-3965	35501311
L102	FM RF Coil 127B	CA-4906	35501342
L103	FM RF Coil 128B	CA-4907	35501352
L104	FM OSC Coil 115L	CA-4674	35501206
L105	Choke Coil 2.2 μ H	CB-2376	35102228
L201	Choke Coil 22 μ H		35125220
L202	Quadrature Coil 223D	CA-3948	35702234
L203	Quadrature Coil 224D	CA-3949	35702244
L204	Choke Coil 2.2 μ H	CB-2376	35102228
L301	Choke Coil 144LY-330K	CB-2402	35105330
L401	AM OSC Coil 416L	CA-4910	35504176
L402	Choke Coil 2.2 μ H	CB-2376	35102228
L403	Choke Coil		35199002
L451	AM Bar Antenna Coil	CA-0668	35400551
T201	FM IFT Coil 207A	CA-7830	35702081
T401	AM IFT 407A	CA-7854	35704081
T402	AM IFT 407B	CA-7835	35704082
T851	Power Transformer	TA-0679	35900276
T851	Power Transformer (Europe/Australia)		35900289

CR COMPONENT

Ref. No.	Description	R/S Part No.	Mfr's Part No.
CR851	Spark Killer (UL)		43000020
CR851	Spark Killer (CSA)		43000017

DIODES

Ref. No.	Type No.	R/S Part No.	Mfr's Part No.	Manufacturer
D101	1S2687	DX-0302	30600560	JRC
D201	1N60P	DX-0162	30600011	UNIZON
D202	1N60P	DX-0162	30600011	UNIZON
D203	1N60P	DX-0162	30600011	UNIZON
D204	1N60P	DX-0162	30600011	UNIZON
D205	1N60P	DX-0162	30600011	UNIZON
D206	1N60P	DX-0162	30600011	UNIZON
D207	1S2075K		30601001	Hitachi
D208	1S2075K		30601001	Hitachi
D209	1S2075K		30601001	Hitachi
D210	1N60P	DX-0162	30600011	UNIZON
D211	RD6.2E	DX-0501	30600691	NEC
D212	1S2075K		30601001	Hitachi
D213	1S2075K		30601001	Hitachi
D214	1S2075K		30601001	Hitachi
D215	1S2075K		30601001	Hitachi
D216	1S2075K		30601001	Hitachi
D301	1S2075K		30601001	Hitachi
D302	1S2075K		30601001	Hitachi
D304	BU1109G	L-0923	30601241	Stanley
D305	BU1109R	L-0922	30601221	Stanley
D701	1S2075K		30601001	Hitachi
D702	1S2075K		30601001	Hitachi
D801	S1VB-10	DX-1121	30601061	Shindengen
D802	HZ-12C1L		30601351	Hitachi

FILTERS

Ref. No.	Description	R/S Part No.	Mfr's Part No.
LPF301	Low Pass Filter BL-21E	C-0864	35000080
LPF302	Low Pass Filter BL-21E	C-0864	35000080

INTEGRATED CIRCUITS				
Ref. No.	Type No.	R/S Part No.	Part No.	Manufacturer
IC201	TA7060P	MX-3356	30900300	Toshiba
IC202	TA7060P	MX-3356	30900300	Toshiba
IC203	HA1137	MX-3546	30900450	Hitachi
IC204	NJM4558D	MX-3449	30900361	JRC
IC301	LA3350	MX-3215	30900310	Sanyo
IC401	HA1197	MX-3467	30900400	Hitachi
IC701	NJM4558D	MX-3449	30900361	JRC

LAMPS			
Ref. No.	Description	R/S Part No.	Mfr's Part No.
PL1	BF311-03030A 8V, 250mA	L-0351	37008006
PL2	BF310-03030A 8V, 250mA	D-1245	37008019
PL3	BF310-03030A 8V, 250mA	D-1245	37008019

METERS			
Ref. No.	Description	R/S Part No.	Mfr's Part No.
M1	TUNING Meter 300 μ A	M-0394	60300001
M2	MULTIPATH Meter 300 μ A	M-0395	60300002

P.C. BOARD ASSEMBLIES			
Ref. No.	Description	R/S Part No.	Mfr's Part No.
0063A	Tuner Board	X7796	97006310
0063B	Power Supply Board	X7796	97006310
0063C	Output Board	X7796	97006310
7169	Meter Lamp Board		97716910

RESISTORS					
Ref. No.	Value (Ω)	R/S Part No.	Wattage (W)	Tolerance (%)	Material
R101	75K		1/4	± 5	Carbon
R102	10K		1/4	± 5	Carbon
R103	56		1/4	± 5	Carbon
R104	100		1/4	± 5	Carbon
R105	220K		1/4	± 5	Carbon
R106	1.5K		1/4	± 5	Carbon
R107	15K		1/4	± 5	Carbon
R108	8.2K		1/4	± 5	Carbon
R109	4.7K		1/4	± 5	Carbon
R110	10K		1/4	± 5	Carbon
R111	22		1/4	± 5	Carbon
R112	100		1/4	± 5	Carbon
R113	1K		1/4	± 5	Carbon
R114	390K		1/4	± 5	Carbon
R115	180K		1/4	± 5	Carbon
R116	330K		1/4	± 5	Carbon
R117	240K		1/4	± 5	Carbon
R201	3.3K		1/4	± 5	Carbon
R202	3.3K		1/4	± 5	Carbon
R203	1.8K		1/4	± 5	Carbon
R204	430		1/4	± 5	Carbon
R205	680		1/4	± 5	Carbon
R206	3K		1/4	± 5	Carbon
R207	390		1/4	± 5	Carbon
R208	680		1/4	± 5	Carbon
R209	33		1/4	± 5	Carbon
R210	430		1/4	± 5	Carbon
R211	560		1/4	± 5	Carbon
R212	15K		1/4	± 5	Carbon
R213	1.2K		1/4	± 5	Carbon
R214	470		1/4	± 5	Carbon
R215	Not Used				
R216	1K		1/4	± 5	Carbon
R217	1.5K		1/4	± 5	Carbon
R218	120		1/4	± 5	Carbon
R219	820		1/4	± 5	Carbon
R220	1K		1/4	± 5	Carbon

Ref. No.	Value (Ω)	R/S Part No.	Wattage (W)	Tolerance (%)	Material
R221	820		1/4	±5	Carbon
R222	33		1/4	±5	Carbon
R223	1K		1/4	±5	Carbon
R224	1.5K		1/4	±5	Carbon
R225	220		1/4	±5	Carbon
R226	820		1/4	±5	Carbon
R227	330		1/4	±5	Carbon
R228	33		1/4	±5	Carbon
R229	150K		1/4	±5	Carbon
R230	430		1/4	±5	Carbon
R231	680K		1/4	±5	Carbon
R232	15K		1/4	±5	Carbon
R233	47K		1/4	±5	Carbon
R234	27K		1/4	±5	Carbon
R235	47K		1/4	±5	Carbon
R236	100K		1/4	±5	Carbon
R237	27K		1/4	±5	Carbon
R238	3.3K		1/4	±5	Carbon
R239	10M		1/4	±10	Solid
R240	33		1/4	±5	Carbon
R241	2.7K		1/4	±5	Carbon
R242	12K		1/4	±5	Carbon
R243	5.6K		1/4	±5	Carbon
R244	1.8K		1/4	±5	Carbon
R245	12K		1/4	±5	Carbon
R246	560		1/4	±5	Carbon
R247	180K		1/4	±5	Carbon
R248	5.6K		1/4	±5	Carbon
R249	56K		1/4	±5	Carbon
R250	10K		1/4	±5	Carbon
R251	27K		1/4	±5	Carbon
R252	56K		1/4	±5	Carbon
R253	56K		1/4	±5	Carbon
R254	820K		1/4	±5	Carbon
R255	820K		1/4	±5	Carbon
R256	3.3K		1/4	±5	Carbon
R257	6.8K		1/4	±5	Carbon
R258	47K		1/4	±5	Carbon
R301	1.8K		1/4	±5	Carbon
R302	5.6K		1/4	±5	Carbon
R303	8.2K		1/4	±5	Carbon
R304	3.3K		1/4	±5	Carbon
R305	68K		1/4	±5	Carbon
R306	1K		1/4	±5	Carbon
R307	1K		1/4	±5	Carbon
R308	3K		1/4	±5	Carbon
R309	3K		1/4	±5	Carbon
R310	8.2K		1/4	±5	Carbon
R311	430		1/4	±5	Carbon
R312	430		1/4	±5	Carbon
R313	3.3K		1/4	±5	Carbon
R314	3.3K		1/4	±5	Carbon

Ref. No.	Value (Ω)	R/S Part No.	Wattage (W)	Tolerance (%)	Material
R315	24K		1/4	±5	Carbon
R316	24K		1/4	±5	Carbon
R317	750K		1/4	±5	Carbon
R318	56K		1/4	±5	Carbon
R319	750K		1/4	±5	Carbon
R320	56K		1/4	±5	Carbon
R321	15K		1/4	±5	Carbon
R322	360		1/4	±5	Carbon
R323	15K		1/4	±5	Carbon
R324	360		1/4	±5	Carbon
R325	9.1K		1/4	±5	Carbon
R326	9.1k		1/4	±5	Carbon
R327	100K		1/4	±5	Carbon
R328	100K		1/4	±5	Carbon
R329	4.7K		1/4	±5	Carbon
R330	68K		1/4	±5	Carbon
R331	6.8K		1/4	±5	Carbon
R332	Not Used				
R333	3.3K		1/4	±5	Carbon
R334	2.7K		1/4	±5	Carbon
R351	1K		1/4	±5	Carbon
R352	1K		1/4	±5	Carbon
R401	220		1/4	±5	Carbon
R402	150		1/4	±5	Carbon
R403	1.5K		1/4	±5	Carbon
R404	300K		1/4	±5	Carbon
R405	1.5K		1/4	±5	Carbon
R406	220		1/4	±5	Carbon
R407	10		1/4	±5	Carbon
R408	10K		1/4	±5	Carbon
R409	10K		1/4	±5	Carbon
R410	1K		1/4	±5	Carbon
R411	680K		1/4	±5	Carbon
R412	390		1/4	±5	Carbon
R413	5.6K		1/4	±5	Carbon
R414	100K		1/4	±5	Carbon
R701	27K		1/4	±5	Carbon
R702	47K		1/4	±5	Carbon
R703	470K		1/4	±5	Carbon
R704	680		1/4	±5	Carbon
R705	560		1/4	±5	Carbon
R706	560		1/4	±5	Carbon
R707	820K		1/4	±5	Carbon
R708	2.7K		1/4	±5	Carbon
R709	15K		1/4	±5	Carbon
R710	10K		1/4	±5	Carbon
R711	3.3K		1/4	±5	Carbon
R712	10K		1/4	±5	Carbon
R713	330K		1/4	±5	Carbon
R714	3.3K		1/4	±5	Carbon
R715	1K		1/4	±5	Carbon

Ref. No.	Value (Ω)	R/S Part No.	Wattage (W)	Tolerance (%)	Material
R801	10		1/4	± 5	Carbon
R802	680		1/4	± 5	Carbon
R803	220		1/4	± 5	Carbon
R804	100		1/4	± 5	Carbon
R805	22K		1/4	± 5	Carbon
R806	200K		1/4	± 5	Carbon
R807	22K		1/4	± 5	Carbon
R808	Not Used				
R809	1.5K		1/4	± 5	Carbon
R810	2.7K		1/4	± 5	Carbon
*R851	2.2M		1/2	± 10	Solid
R852	10		2	± 10	Wire Wound

* R851: Not Used in European and Australian models

SWITCHES

Ref. No.	Description	R/S Part No.	Mfr's Part No.
SW1	POWER	S-0861	27200110
SW1	POWER (Europe/Australia)		27200112
SW2	SELECTOR	S-0862	27100157
SW3-SW7	Push 5 Keys	S-7383	27200103

THERMISTOR

Ref. No.	Description	R/S Part No.	Mfr's Part No.
TH201	TD5-C220	T-1201	30700120

TRANSISTORS

Ref. No.	Type No.	R/S part No.	Part No.	Manufacturer	Substitute	
					Type No.	Manufacturer
TR101	3SK45		30400071	Hitachi		
TR102	3SK45		30400071	Hitachi		
TR103	2SC1675(L)		30201121	NEC		
TR201	2SC930(D)		30200271	Sanyo		
TR202	2SC930(D)		30200271	Sanyo		
TR203	2SC536(F)		30200131	Sanyo	2SC945	NEC
TR204	2SC536(F)		30200131	Sanyo	2SC945	NEC
TR205	2SC536(f)		30200131	Sanyo	2SC945	NEC
TR206	2SC536(F)		30200131	Sanyo	2SC945	NEC
TR207	2SC536(F)		30200131	Sanyo	2SC945	NEC
TR301	2SA942		30000622	Toshiba		
TR302	2SC2089		30201403	Toshiba		
TR303	2SA942		30000622	Toshiba		
TR304	2SC2089		30201403	Toshiba		
TR305	2SC945		30201031	NEC		
TR306	2SC945		30201031	NEC		
TR307	2SC536(F)		30200131	Sanyo		
TR401	2SC536(F)		30200131	Sanyo	2SC945	NEC
TR701	2SC536(F)		30200131	Sanyo	2SC945	NEC
TR801	2SD325		30300151	Sanyo	2SD330	Sanyo
TR802	2SC536(F)		30200131	Sanyo	2SC945	NEC
TR803	2SB560		30100041	Sanyo	2SB631	Sanyo

VARIABLE CAPACITORS			
Ref. No.	Description	R/S Part No.	Mfr's Part No.
VC101	Tuning Capacitor (Include TC101-TC103, TC105 & TC106)	C-4652	26370111
TC104	Trimmer ECV- 6MD34 X 72G	C-0424	26010023

VARIABLE RESISTORS			
Ref. No.	Description	R/S Part No.	Mfr's Part No.
VR201	FM Signal Meter Sensitivity Adjust 50 K/B		28101503
VR202	FM Muting & Auto-Stereo Level Adjust 100 K/B	S-0863	28101104
VR301	19 kHz Adjust 5 K/B	P-0840	28101502
VR302	MPX Separation 1 K/B		28101102
VR351a,b	Tuner Output Level Control 10 K/B	P-1893	28000148
VR401	AM Signal Meter Sensitivity Adjust 1 K/B	P-0839	28101102
VR402	AM Output Level Control 50 K/B	S-0864	28101503

MISCELLANEOUS PARTS LIST

Ref. No.	Description	R/S Part No.	Mfr's Part No.
1	Jumper Wire		92000001
2	Shield Plate C	HB-7860	09089001
3	Irrax Tube 0.7 x 15 mm		31140003
4	Wire Wrap Pin 13mm		19044001
5	UL Tube 1 x 10 mm		31501062
6	Shield Plate A	HB-7858	09087001
7	Shield Plate B	HB-7859	09088001
8	Back Panel Assembly		11513A01
9	Bar Antenna Clamp	A-4413	84290001
10	Antenna Terminal Board	J-4533	53032500
11	AC Cord with Plug		62110038
	AC Cord with Plug (Europe)		62110039
	AC Cord with Plug (Australia)		62010013
12	Cord Strain Relief SR-4P4		74089001
13	Fuseholder FH002 (UL)	F-1017	34032001
	Fuseholder N3 (CSA)		34069001
	Fuseholder (Europe/Australia)		34065001
14	Plastic Rivet M3		84254001
15	Fuse 0.5A 125V (UL)	HF-0025	38337105
	Fuse 0.5A (for CSA)		38107105
	Fuse 0.3A 250V (Europe/Australia)		38444203
16	Fiber for Line Cord Ant.		75017002
17	Line Cord Antenna		63101001
18	Front Chassis	Z-4139	03083002
19	Meter Bracket-Panel	HB-7862	63406001
20	Dial Scale Assembly	D-5317	20108001
21	Dial Lamp Socket	J-6576	34072001
22	Tuning Shaft Assembly	D-3252	23056001
23	Plastic Pulley	D-0250	84085001
24	Pulley Shaft		24003002

Ref. No.	Description	R/S Part No.	Mfr's Part No.
25	Binding Head Screw tite C 3 x 5		40000091
26	Binding Head Screw tite 3 x 8		40630081
27	Rubber Sponge for Meter	HB-7864	74156001
28	Rubber for Dial Scale	HB-7863	74155001
29	Dial Scale Mounting Bracket		63412001
30	Lamp Board	D-1245	08060001
31	Screw M3 x 6		40330061
32	Ground Lug		51098002
33	Fiber Washer for Tuning Shaft		74159001
34	Pulley Shaft	HB-5101	24006001
35	Hex Nut 9M		41000004
36	Angle Bracket for Power Transformer	RT-1400	63401002
37	Spring Washer M4		42250441
38	Tapping Screw M4 x 15 Black		40640155
39	Flat Washer M4		42120421
40	Dial Pointer Assembly	D-1246	25048001
41	Mylar for Dial Pointer	RT-1194	84276001
42	Ground Terminal	HB-4106	63319001
43	Wire Clamp		63075001
44	PVC Tube for Wire Clamp		31501426
45	Tapping Screw M3 x 8 Black		40630085
46	Dial Drum	D-0400	21008003
47	Terminal Strip		51100002
48	Spring Washer M3		42250341
49	Fiber Insulator		75066001
50	Spring Coil for Dial Drum		19017001
51	Front Panel Assembly	Z-4141	10513A01
52	Push Button	K-3028	29295001
53	SELECTOR Knob	K-3026	29333001
54	Tuning Knob	K-3030	29293001
55	Plastic Foot		74074001
56	Screw M5 x 15		40350151
57	Plastic Washer for Cabinet		84092001
58	Wooden Cabinet	Z-4142	85083001
59	Brazier Head Screw tite C M3 x 8		40000120
60	Bottom Plate	Z-4135	05056001
61	Light Shield Sponge A		73256001
62	Light Shield Sponge B		73257001
63	2P Pin Jack	J-0974	33021300
64	Center Chassis		01101001
65	Pulley Fit Metal	HB-7866	63428001
66	Pulley Fit Metal	HB-7865	63404001
67	Side Chassis (Right)	Z-4133	04027001
68	Side Chassis (Left)	Z-4140	04028001

HA1197 MX-4737

RADIO SHACK  A DIVISION OF TANDY CORPORATION

U.S.A.: FORT WORTH, TEXAS 76102
CANADA: BARRIE, ONTARIO L4M 4W5

TANDY CORPORATION

AUSTRALIA	BELGIUM	U. K.
280-316 VICTORIA ROAD RYDALMERE, N.S.W. 2116	PARC INDUSTRIEL DE NANINNE 5140 NANINNE	BILSTON ROAD WEDNESBURY, WEST MIDLANDS WS10 7JN

#0063A

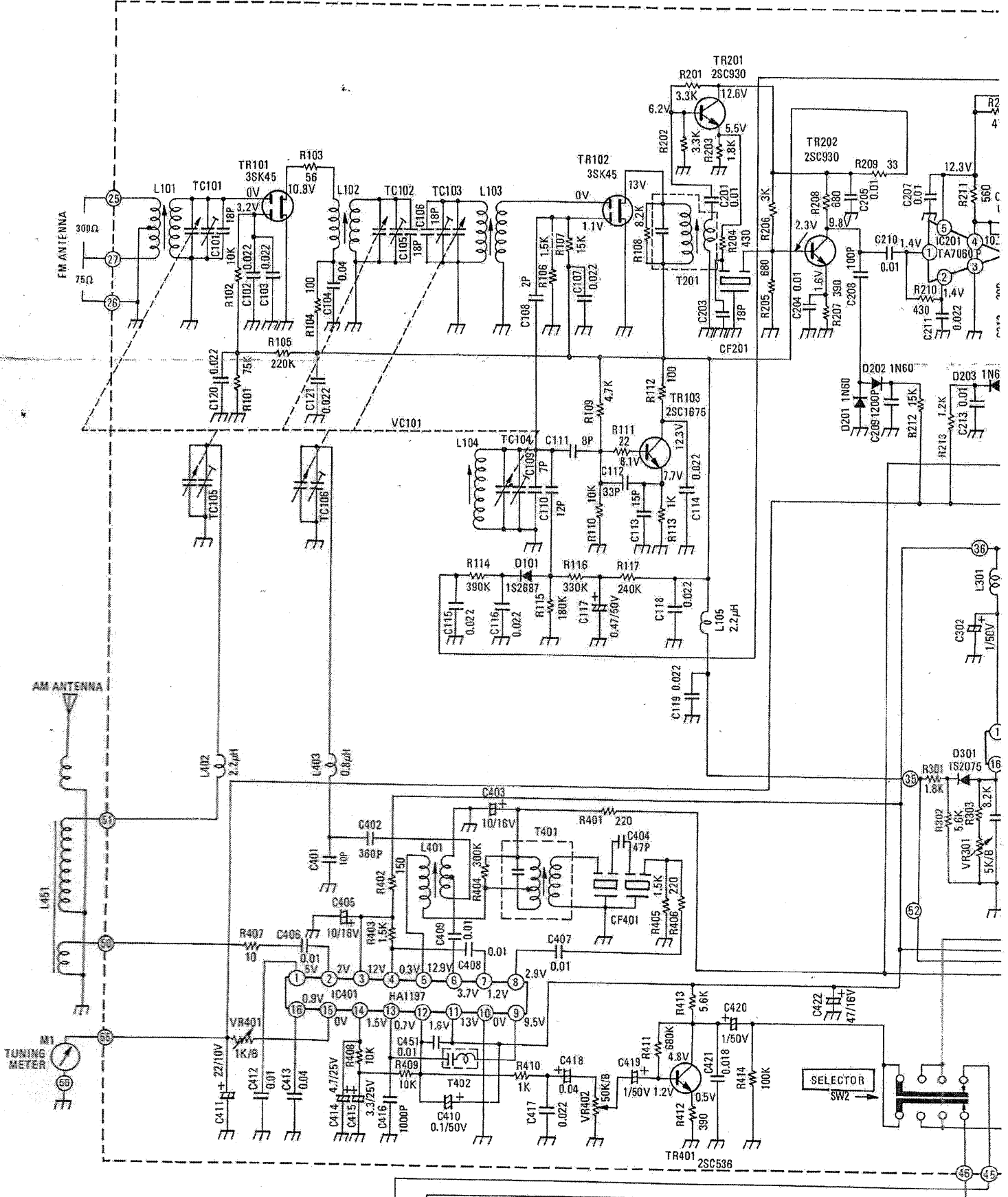

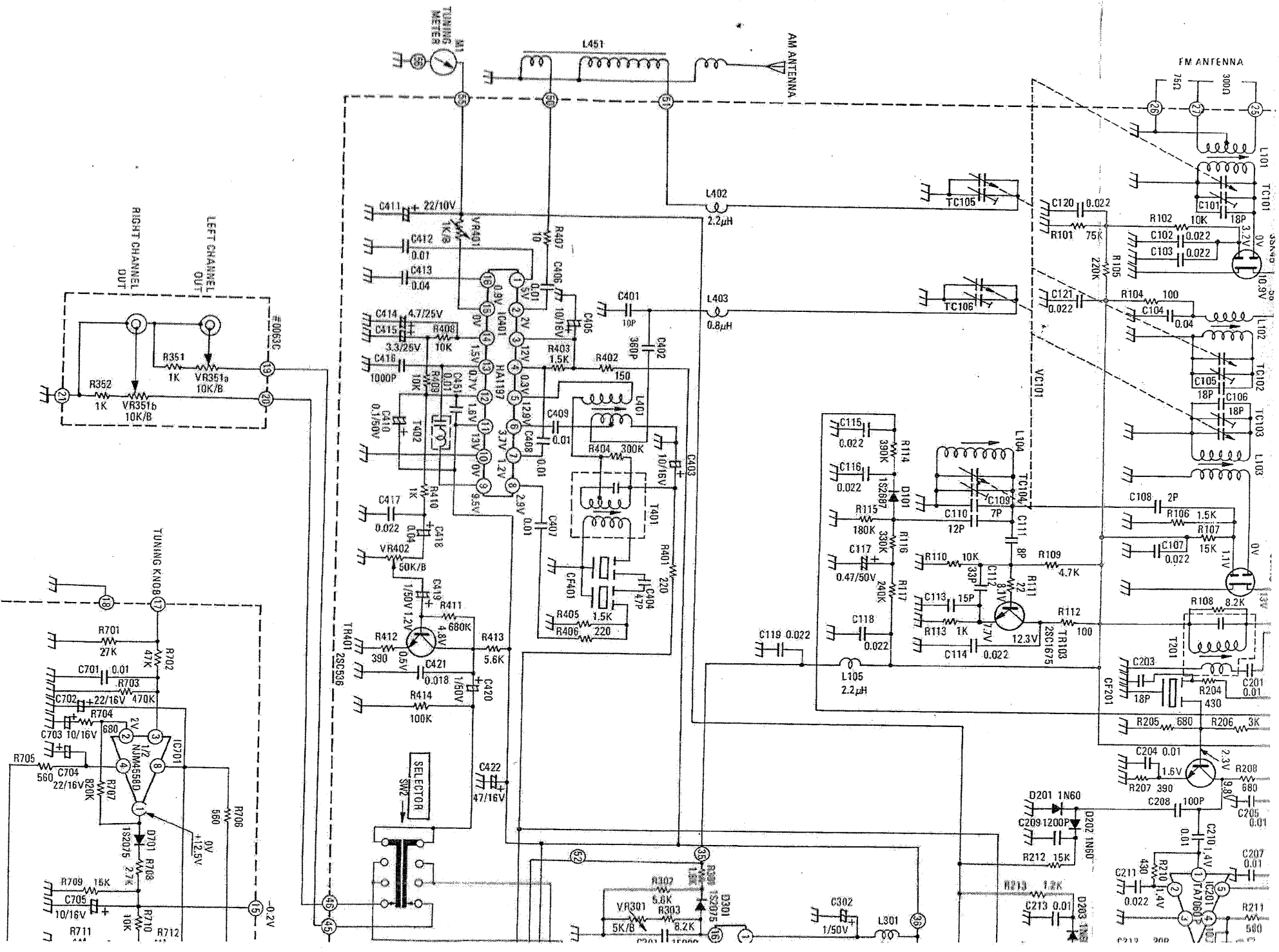

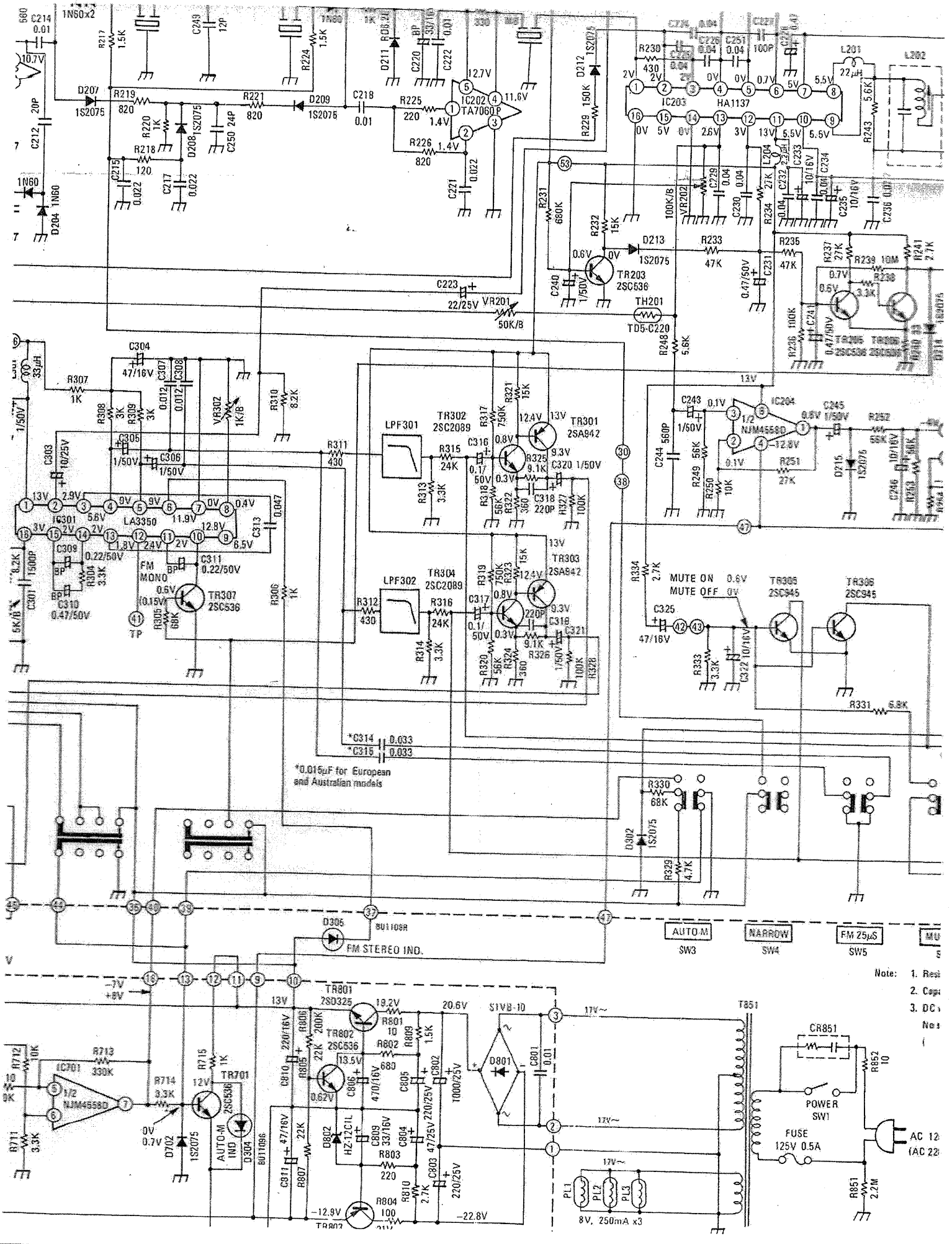

*C314, 0.033
 *C315, 0.033
 *0.015µF for European and Australian models

- Note:
1. Resistor
 2. Cap
 3. DC
- Net

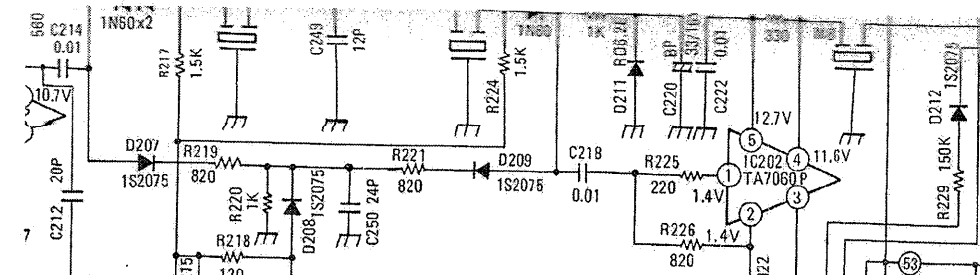
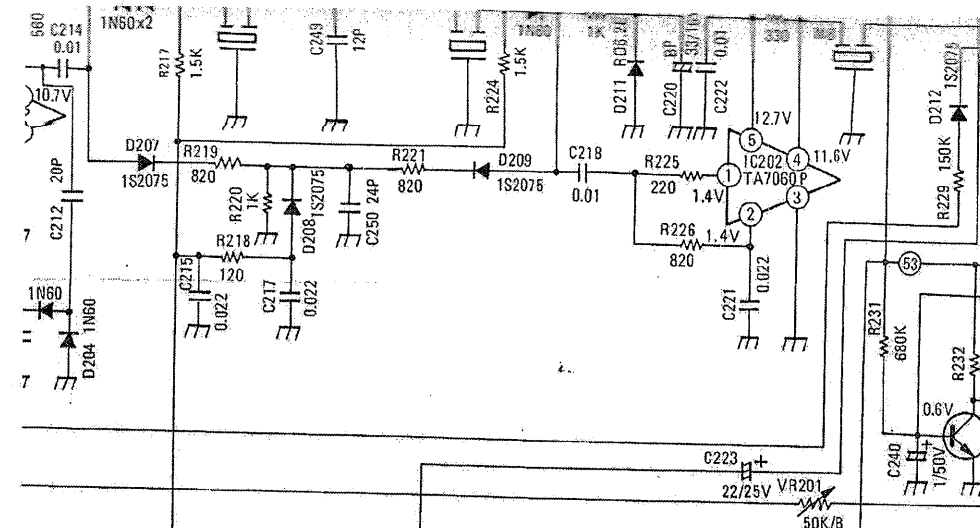
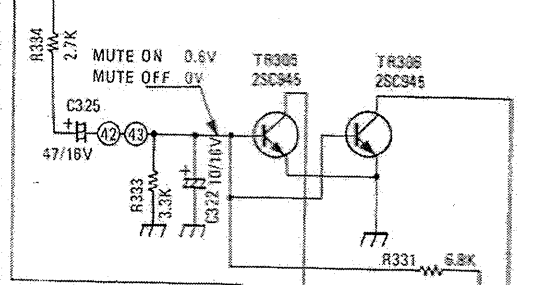
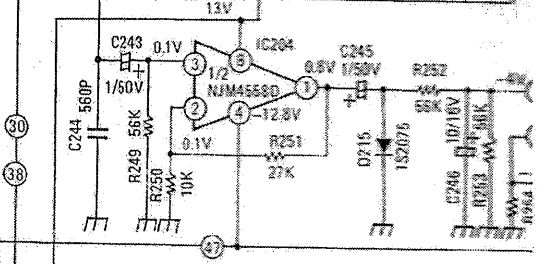
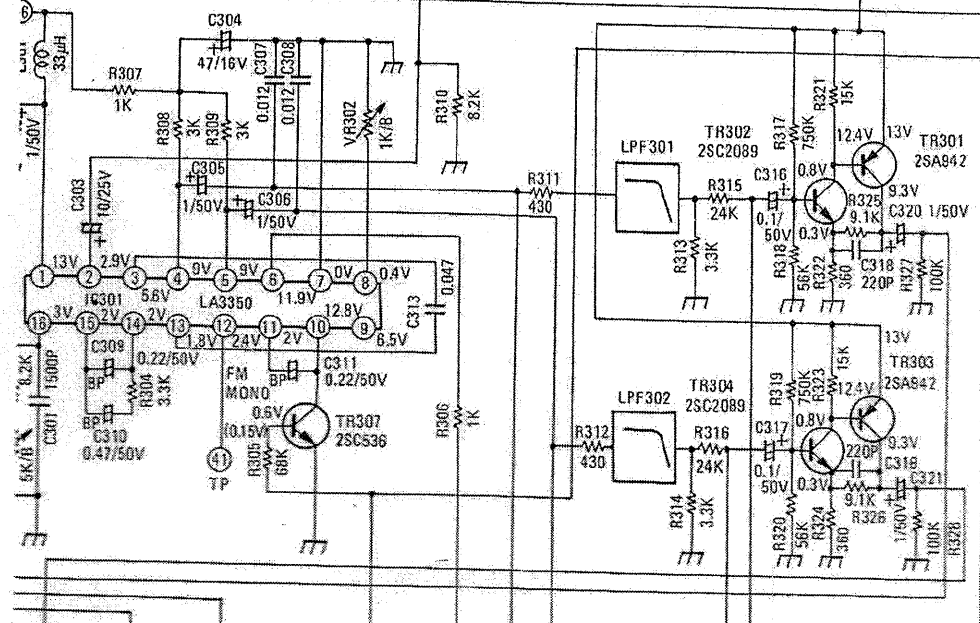
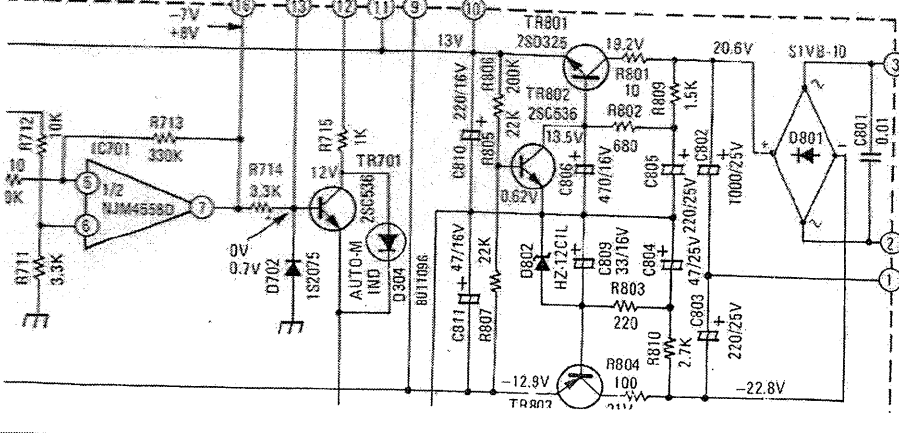
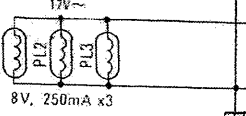
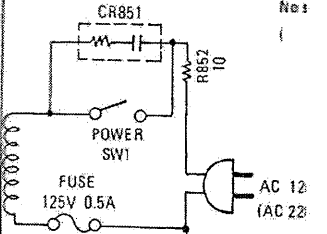

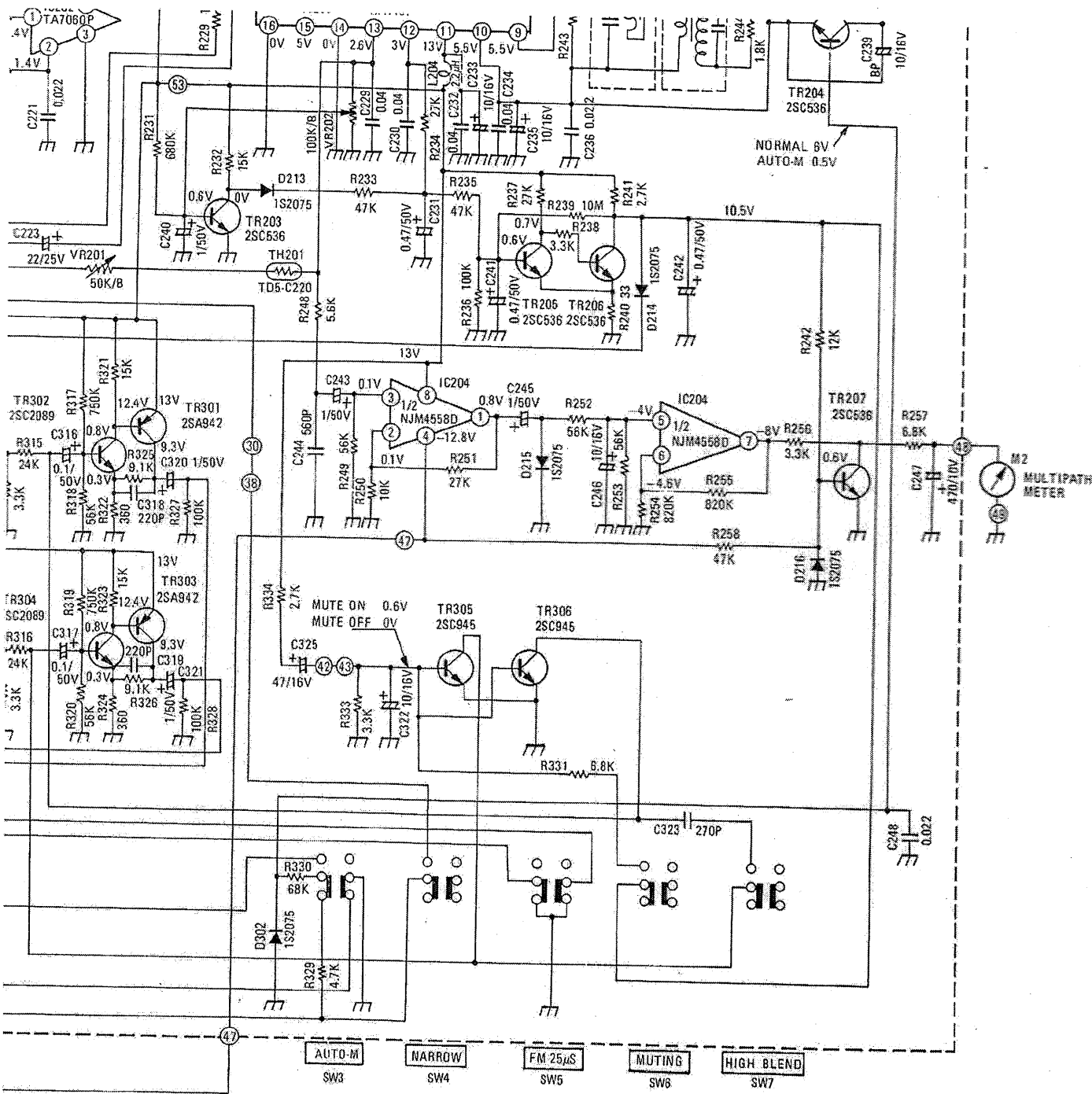

Note: 1. Resistance values are indicated in ohms unless otherwise specified (K=1,000, M=1,000,000).
 2. Capacitance values are shown in microfarads unless otherwise noted (P=micro-micro farads).
 3. DC voltages are referenced to ground under the following conditions.
 No signal.
 (): 1,000 μ V FM stereo signal.

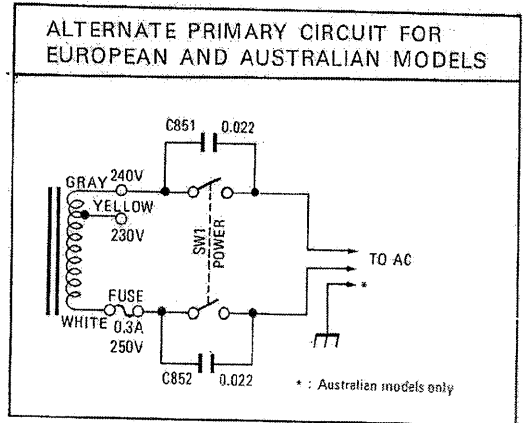
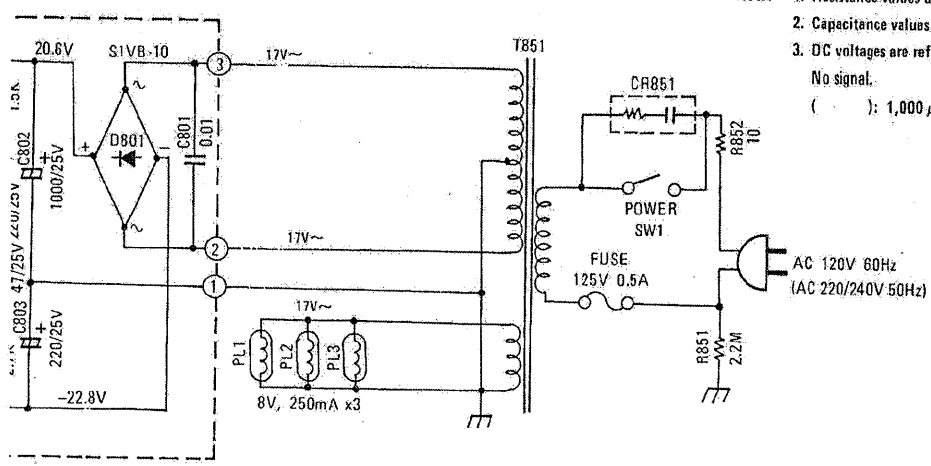

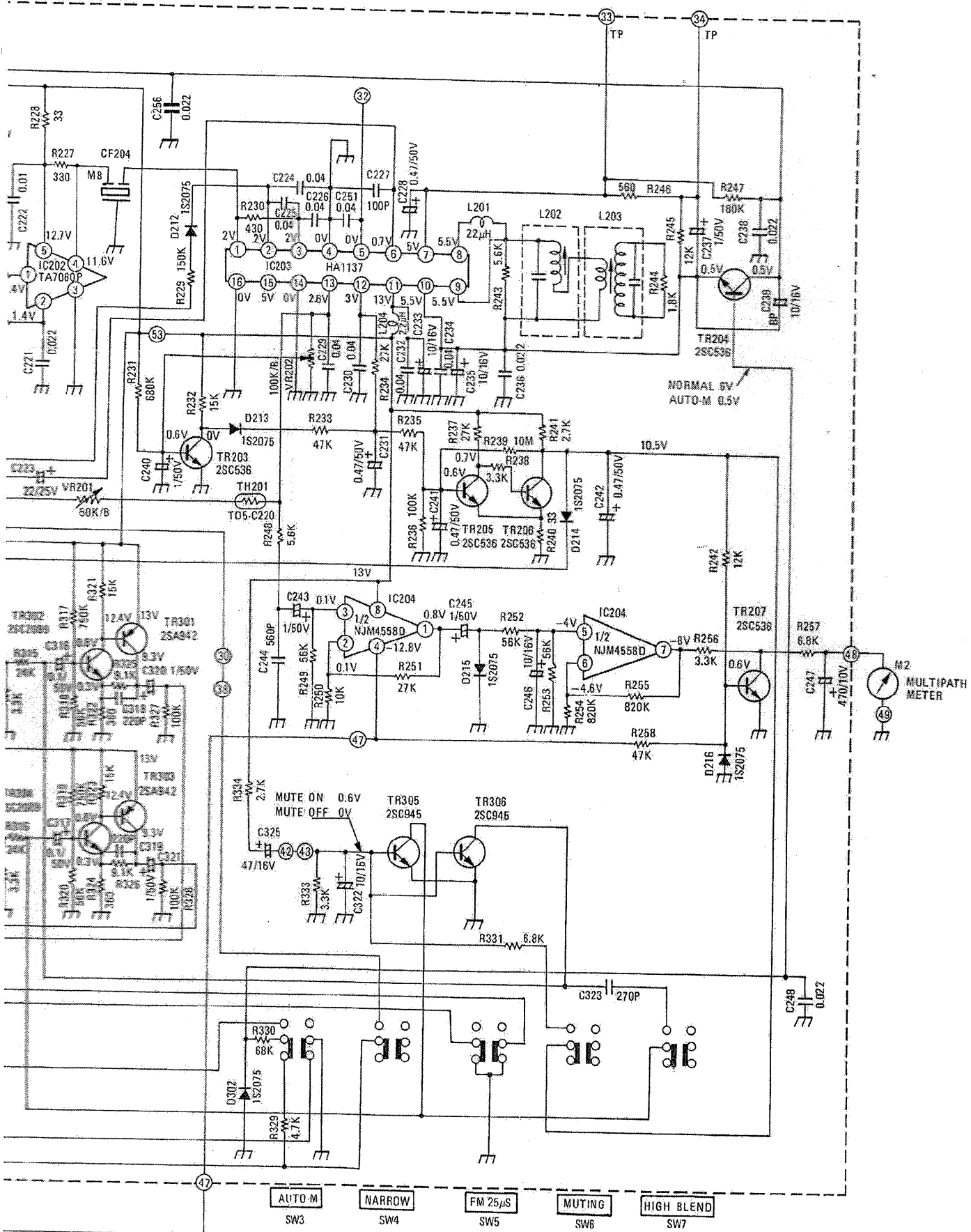

Note: 1. Resistance values are indicated in ohms unless otherwise specified (K=1,000, M=1,000,000).
 2. Capacitance values are shown in microfarads unless otherwise noted (P=micro-micro farads).
 3. DC voltages are referenced to ground under the following conditions.
 No signal.



