



SHERWOOD



MICRO/CPU 100

INSTALLATION and
OPERATION MANUAL

Dear Customer:

Your Sherwood MICROJCPU 100 Tuner represents a State-of-the-Art level in computer technology applied for the first time to a high-fidelity component. The combination of features and performance this tuner provides would be impossible to obtain using conventional technology, and we at Sherwood are confident that these unparalleled technological advances will provide you with many years of personal pleasure and enjoyment.

Thank you for choosing Sherwood!

Sincerely,

Sherwood Electronics Laboratories, Inc.

Contents

| | |
|--|----|
| Front Panel Features | 4 |
| Installation | 8 |
| Tuner Connection | 6 |
| Tuner Reception | 7 |
| Tuner Operation | 8 |
| Additional Features | 11 |
| Block Diagram | 12 |
| Specifications | 14 |
| Typical Performance Curves | 16 |
| Common Installation Problems | 19 |
| Notes | 20 |
| Warranty Information | 21 |
| Station Log | 22 |

WARNING: TO PREVENT FIRE OR SHOCK HAZARD, DO NOT EXPOSE THIS TUNER TO RAIN OR MOISTURE.

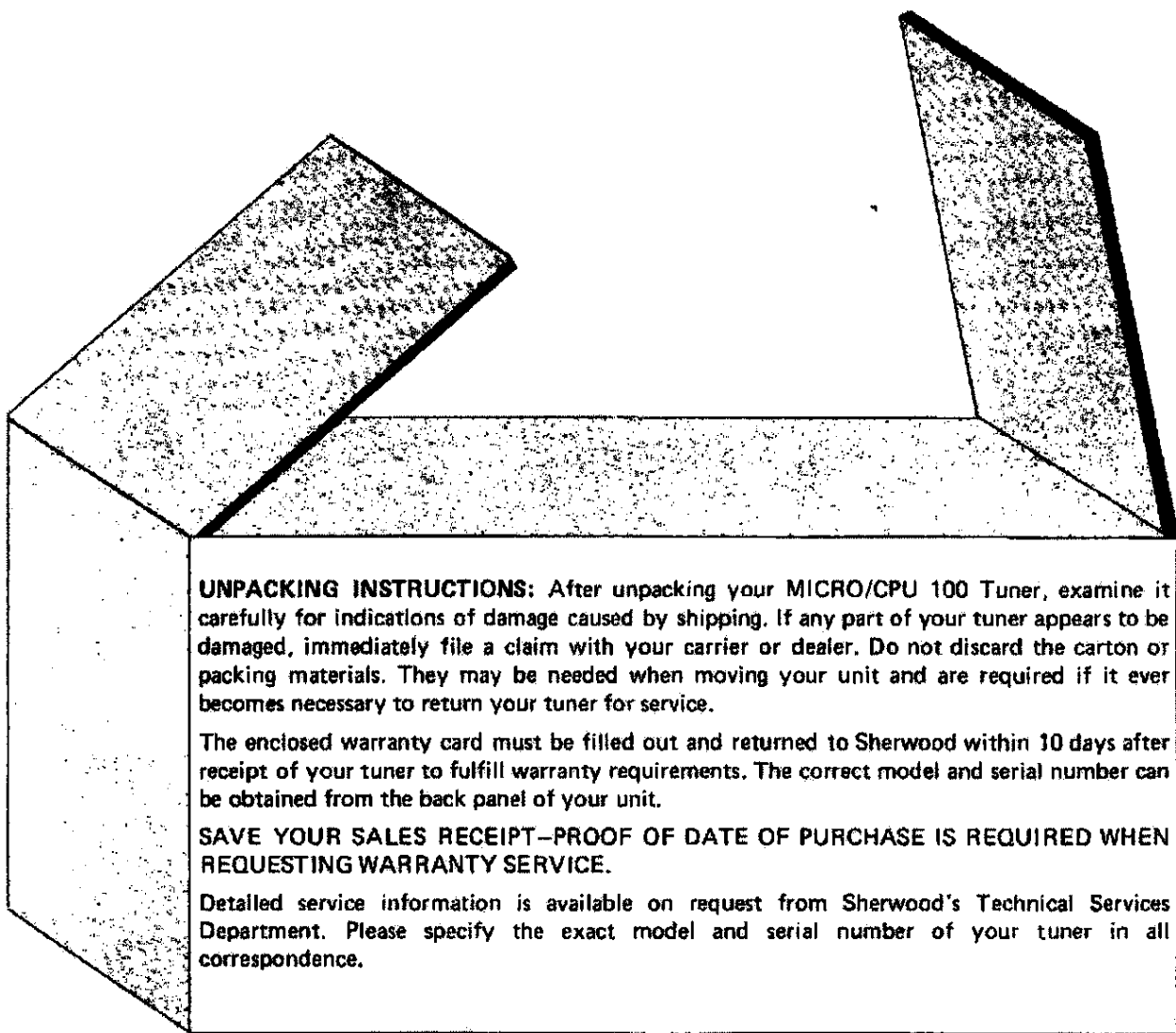

UNPACKING INSTRUCTIONS: After unpacking your MICRO/CPU 100 Tuner, examine it carefully for indications of damage caused by shipping. If any part of your tuner appears to be damaged, immediately file a claim with your carrier or dealer. Do not discard the carton or packing materials. They may be needed when moving your unit and are required if it ever becomes necessary to return your tuner for service.

The enclosed warranty card must be filled out and returned to Sherwood within 10 days after receipt of your tuner to fulfill warranty requirements. The correct model and serial number can be obtained from the back panel of your unit.

SAVE YOUR SALES RECEIPT—PROOF OF DATE OF PURCHASE IS REQUIRED WHEN REQUESTING WARRANTY SERVICE.

Detailed service information is available on request from Sherwood's Technical Services Department. Please specify the exact model and serial number of your tuner in all correspondence.

Front Panel Features

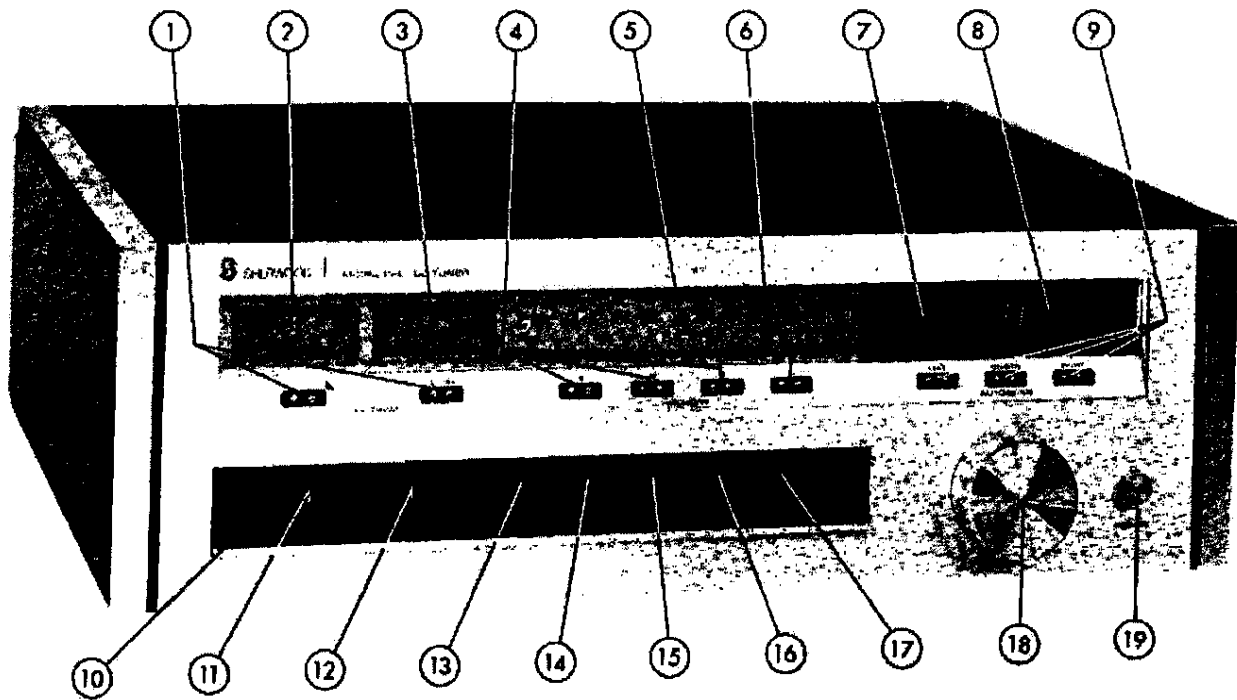

Figure 1.

1. **PROGRAM SWITCHES:** Permit programming into memory of up to 48 sets of station identification characters for readout on the Alpha Numeric LED Display. (Page 8.)
2. **SIGNAL STRENGTH METER:** Indicates the relative signal strength of the selected FM station. (Page 7.)
3. **MULTIPATH METER:** Indicates the amount of undesirable, reflected signal being received along with the main transmitter signal for best antenna orientation. (Page 7.)
4. **MEMORY SWITCHES:** 4 touch switch controls that offer convenient storage of 4 favorite stations for instant tuning. (Page 9.)
5. **ILLUMINATED TUNING SCALE.**
6. **ANALOG DIAL POINTER:** Miniature LEDs arranged in a line below the tuning scale to indicate the movement of a conventional dial pointer. (Page 8.)
7. **ALPHA NUMERIC DISPLAY:** 4-character LED readout used with the Program switches for up to 48 sets of user-programmable letter/number combinations. (Page 8.)
8. **DIGITAL FREQUENCY DISPLAY:** Large LED display that indicates the exact frequency of the station selected. (Page 8.)
9. **AUTO-SCAN SWITCHES:** Right (and Left) touch switches that scan up (and down) the FM band to the next broadcasting station or stereo broadcasting station. (Page 9.)
10. **DOOR PANEL:** For convenient access to various control functions.
11. **OUTPUT LEVEL CONTROL:** Volume control for matching the tuner output level to that of other signal sources in your system. (Page 6.)
12. **MUTING LEVEL CONTROL:** Adjusts the threshold at which interstation noise and very weak stations are muted when tuning between desired stations. (Page 10.)
13. **MUTING SWITCH:** Defeats the muting of very weak stations (and interstation noise) permitting reception of any signal strong enough to be detected by the tuner. (Page 10.)
14. **SELECTIVITY SWITCH:** 2 separate IF systems provide both a "Normal" bandwidth for superb selectivity and a "Wide" bandwidth for exceptional stereo fidelity. (Page 10.)
15. **AUTO STEREO FILTER SWITCH:** Offers maximum noise reduction on noisy stereo broadcasts with a minimum of loss of high frequency response. (Page 10.)
16. **MODE SWITCH:** Provides for the selection of either Stereo or Mono mode of operation.
17. **DEEMPHASIS SWITCH:** Selects proper deemphasis (equalization) for either normal FM transmission or 25 μ sec specially encoded broadcasts. (Page 10.)
18. **TUNING CONTROL:** Operates an electronic detection circuit that provides smooth across-the-dial tuning without the error and mechanical limitations associated with conventional flywheel systems. (Page 8.)
19. **MAIN POWER SWITCH.**

Installation

When installing the MICRO/CPU tuner, the following situations should be avoided that could possibly damage the tuner:

- Stacking components which limits ventilation;
- Places with poor ventilation;
- Places exposed to direct sunlight, close to heating units or other sources of heat;
- Excessively humid or dusty locations;
- Sloping locations or those subject to vibration.

IMPORTANT: Allow at least two inches of space behind your tuner for adequate ventilation as well as cabling convenience. Never place the unit near

radiators or in front of heating vents. Excessive heat tends to shorten the life of the internal components. (This is an important fact to remember in caring for all the elements of your high-fidelity system, including records and tapes.)

VERTICAL MOUNTING: Although your Sherwood MICRO/CPU 100 is designed to be placed in a horizontal position, it may be mounted vertically (with the face plate up). In this type of installation, do not use the enclosure. The tuner may be supported completely by its escutchcon in a custom installation; however, this type of support is not adequate to withstand shipping.

Tuner Connection

The MICRO/CPU tuner offers two main audio outputs: **FIXED** and **VARIABLE**. The fixed output offers a nominal output level that is governed by the tuner and never varies. For tape recording directly from the tuner or feeding a stereo system that requires a nonvarying signal source, this pair of outputs would be selected. The Variable output is adjustable with a front panel volume control located behind the door panel, and is usually the choice for most stereo systems since it permits adjusting the tuner output to match that of other sources (tape, phono, etc.). This will also aid taping, external processing or other components in your system that may require adjustment if a signal level varies between sources.

Using the pair of cables provided, connect the tuner output of your choice to the tuner (or aux) inputs on your control amplifier.

COMPOSITE OUTPUT: This jack is provided on the back panel for use in conjunction with an adapter (when approved by the FCC) to produce 4 discreet channels from an FM source. In the event that the Federal Communications Commission approves a standard method of 4-channel transmission, Sherwood will then offer an FM 4-Channel adapter for use with this jack.

Tuner Reception

FM ANTENNA: The 'dipole' antenna provided with your tuner should be adequate for local FM reception. Connect this antenna to the two terminals marked '300Ω' on the back of the tuner per Figure 2. Attach the antenna's 'arms' horizontally to a non-metallic surface such as a window, a wall, or the rear surface of a cabinet or shelf—whichever position renders the best overall reception. In general, the antenna is best positioned when it is as high as possible above floor level and its arms are perpendicular to the source of transmission. However, in some strong signal localities, placement under a rug or carpet may prove acceptable.

If you are located a considerable distance from the FM transmitters, an outdoor FM antenna (available from your Sherwood Dealer or TV parts distributor) may be required to reduce background noise, fading, or interference. The following notes should be helpful for any antenna installation:

1. It is always advisable to keep the antenna cable as short as possible.
2. Try and keep the antenna as far away as practical from the street to avoid ignition noise from automobiles and other vehicles.
3. Since antennas are directional, its height and direction should be adjusted while actually receiving a favorable FM station.

4. Avoid placing the antenna lead-in cable near the electrical power line that enters your home.

When using a 75 ohm antenna system, its coaxial cable should be connected as follows: The outer braid shield (ground) should be held in place with the metal bracket per Figure 2 (which also establishes a ground connection for the shield) and the inner conductor wire should be connected to the terminal marked '75Ω.'

SIGNAL STRENGTH and MULTIPATH METERS: A most important factor affecting FM signal quality is multipath reception. This is caused by signal reflections from buildings, hills, etc., that reach the tuner's antenna later in time than the original signal. Particularly with FM stereo, multipath can cause severe distortion and loss of channel separation. To help combat the effects of multipath, the MICRO/CPU 100 employs a Multipath meter—a visual readout of the strength of unwanted, reflected signals. Because antenna orientation is a big factor in minimizing multipath reception, a directional antenna equipped with a rotor to "aim" the antenna for minimum multipath would be desirable. Since the Signal Strength meter indicates the relative strength of the incoming signal in its entirety, by checking the two meters for both minimum multipath and enough

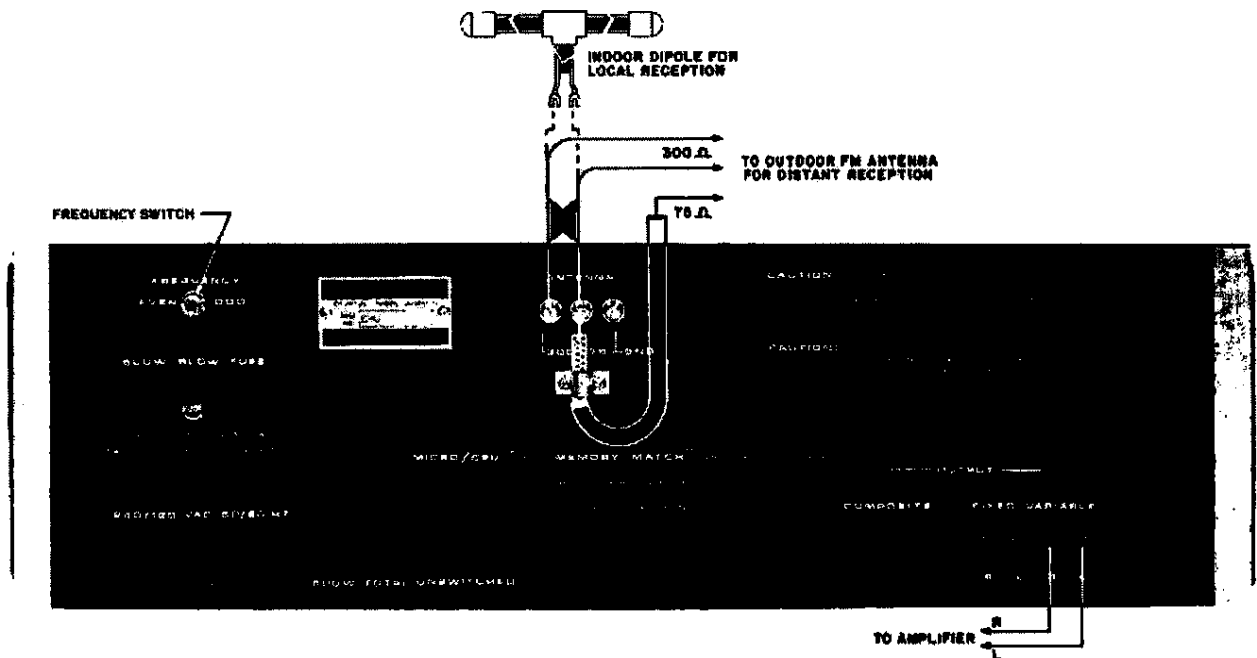

Figure 2

signal strength for noise-free stereo, you have optimized reception for any selected station. If the dipole supplied or a directional antenna without a rotor is adequate, vary the antenna direction until the best overall average of signal strength and low multipath for favorite stations is obtained.

The MICRO/CPU 100's computer has a tuning accuracy of greater than .0024%; therefore, the tuner has no need for a conventional "center-tune" meter or an oscilloscope to indicate accurate tuning. As mentioned, the two meters are provided to aid in proper antenna orientation, and should not be treated as "maximum deflection" or "center-tuning" indicators.

Tuner Operation

Once the connections outlined in the previous sections have been made, your MICRO/CPU 100 tuner is completely operational. Although the MICRO/CPU 100 is not difficult to operate, careful study of this section of the operator's manual will allow you to fully enjoy its many versatile features.

NOTE: When first operating your MICRO/CPU 100, make sure that all the flip switches are in the 'up' (normal) position. These switches are located behind the door on the front panel. To open the door, press inward at the bottom edge. The hidden latch will release and the door will open. To engage the latch, simply close the door.

Also, make sure that the Frequency switch, located on the back panel, is in the correct position. For use in the U.S., the switch must be in the odd position since all U.S. FM stations are assigned odd numbered frequencies by the Federal Communications Commission. In other countries, check with your local broadcasters to determine if they are broadcasting on odd or even numbered frequencies.

MANUAL TUNING: Your MICRO/CPU 100 tuner may be manually tuned by turning the Tuning Control to the desired station. The Digital Frequency Display gives the exact frequency in megahertz (MHz). The Analog Dial Pointer indicates relative position on a conventional FM dial scale, when attempting to locate a particular station. Once you have tuned to the desired station, there is no need to 'fine tune' as the MICRO/CPU 100's computer will 'lock in' on the desired station.

STATION CALL LETTER PROGRAMMING: To program the call letters for a particular station, manually tune to that station. To initiate the programming sequence, touch the Alpha switch located on the front panel. By turning the Tuning Control slightly, the letter "A" will appear in the first position of the Alpha Numeric Display. Rotate the Tuning Control until the desired character appears in the Alpha Numeric Display. Touch the Store switch to retain the character. The letter "A" will appear in each successive position of the Alpha Numeric Display, when the previous character is stored. Rotate the Tuning Control as described above for each position of the Alpha Numeric Display. After storing the fourth character, the computer automatically switches your MICRO/CPU 100 to its normal operating mode.

Once the call letters are programmed to a particular frequency, whenever you tune to that frequency, the associated call letters will appear in the Alpha Numeric Display. If you wish to change the call letters, use the previously outlined procedure.

If the Alpha switch is unintentionally touched (initiating the programming sequence), the programming sequence may be cancelled by touching the Alpha switch again.

NOTE: The Alpha Numeric Display of your MICRO/CPU 100 can be programmed with any four character combination of letters, numbers, and punctuation found on a standard typewriter keyboard. Since some stations have less than four call letters, a blank, or space, is also provided. Do not program all positions of the Alpha Numeric Display with blanks. Doing so will lessen the number of call letters sets that can be programmed into the computer's memory.

A maximum of 48 sets of call letters can be programmed into the computer's memory. If you attempt to program in more than 48 sets, the word "FULL" will appear in the Alpha Numeric Display for approximately two seconds. Additional sets may be programmed in, if unwanted sets are first deleted. Call letter sets may be deleted by tuning to the station whose call letters you wish to delete, touching the Alpha switch, and then touching the Memory "A" switch.

MEMORY SWITCH PROGRAMMING: Four of your favorite stations may be instantly tuned by touching the front panel Memory switches. To store a station location in a particular Memory, tune to the desired station, touch the Store switch, and then touch the desired Memory switch ("A," "B," "C," or "D").

The station can now be instantly tuned by touching the associated Memory switch. The unique Memory Match feature of your MICRO/CPU 100 will light the associated Memory switch each time that station is tuned. This alerts you to the fact that the tuned station is stored in a particular Memory. Stations in the Memory may be changed by using the previously outlined procedure.

AUTO SCAN: Touch switches allow you to scan up or down (to the right or to the left of) the entire FM band. When activated, the computer proceeds in the direction you choose; to the next broadcasting station. If used in conjunction with the Stereo Only switch, the computer will select only those stations broadcasting in stereo. If no stations are detected, your MICRO/CPU 100 scans the entire FM band once and terminates at the original frequency.

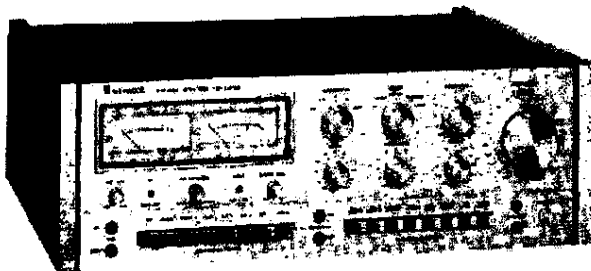

HP2000 Control Amplifier



MICRO/CPU 100 FM Tuner

SHERWOOD



SELECTIVITY SWITCH: Your MICRO/CPU 100 employs two distinct IF systems. When neighboring stations on the FM band interfere with the reception of a desired station, the Normal IF system, which provides superb selectivity, should be used. The Wide IF system provides exceptional stereo separation and low distortion. The Wide IF system should be used whenever neighboring stations do not interfere with the reception of the desired station.

The Normal or Wide IF system is selected by the front panel Selectivity switch.

MUTING: The electronic muting circuit will remove noise normally heard between stations of highly sensitive FM tuners. The Muting Level Control should be adjusted to the point at which the interstation noise is eliminated. If the Muting Level control is adjusted for higher signal level muting (more clockwise), the sound of extremely distant, weak stations may also be attenuated along with the interstation noise. Therefore, when desiring to tune in a known weak station, adjust the control more counterclockwise to reduce the signal level muting threshold, or defeat the muting circuit totally using the Muting switch.

AUTO STEREO FILTER: The Auto Stereo Filter is a noise cancelling circuit that automatically reduces background noise without affecting frequency response in proportion to the strength of the incoming signal. Since the Auto Stereo Filter is

inoperative whenever a signal is strong enough to be heard in full stereo without noise, Sherwood suggests that it be left on.

The Auto Stereo Filter may be defeated by depressing the front panel Auto Stereo Filter switch to the "OUT" position.

MODE SWITCH: When the Mode switch is depressed to the Mono position, the multiplex circuitry is bypassed and all broadcasts will be heard monophonically.

AUTOMATIC STEREO/MONO SWITCHING: The MICRO/CPU 100 incorporates a unique noise-threshold-gated automatic stereo/mono switching circuit. When the Mode switch on the front panel is set to the Stereo position, and the FM program selected is being broadcast in mono, this automatic circuit switches the tuner into a mono mode. Stereo transmission is indicated by the FM Stereo Indicator Light located in the tuning scale area, and the tuner will automatically switch to stereo or mono depending on the signal received.

FM DEEMPHASIS: The MICRO/CPU 100 tuner incorporates a front panel selectable, post-emphasis FM equalization circuit. With the switch in the "NORM" (normal) mode (75 μ sec. for domestic and 50 μ sec. for foreign), reception is equalized for standard FM transmission. When receiving a Dolby* encoded broadcast and employing a Dolby* noise reduction adapter, the deemphasis equalization should be set for 25 μ sec. (for both domestic and foreign).

* The word 'Dolby' is a trademark of Dolby Laboratories, Inc.

Additional Features

AC CONVENIENCE OUTLET: The MICRO/CPU 100 tuner offers an AC outlet on the back panel. Do not connect any component or appliance that exceeds the wattage rating specified for the outlet; to do so might damage the tuner and is a fire hazard as well.

FREQUENCY SWITCH: All FM stations in the U.S. are assigned odd numbered frequencies by the Federal Communications Commission. The Frequency switch on your MICRO/CPU 100 must be in the odd position for reception of U.S. FM stations. In other countries, check with your local broadcasters to determine if they are broadcasting on odd or even numbered frequencies and switch the Frequency switch to the appropriate position.

FUSE: The internal circuitry of your MICRO/CPU 100 is protected from excessive power by an AC line fuse. This fuse is a ½ amp slo-blo type (¾ amp slo-blo for 200-260 volts). If the fuse should blow (open), replace it with the same type fuse or contact Sherwood's Service Department. Do not replace with a higher value fuse; to do so is a fire hazard and invalidates your warranty.

VOLTAGE ADJUSTMENT: Your MICRO/CPU 100 tuner is adjusted to operate at the correct power supply voltage of your area prior to shipment from Sherwood. If you move after purchasing it or send it as a gift to a friend living in an area where the voltage is different, it may be necessary to adjust the Voltage switch.

To adjust the Voltage switch remove the walnut end panels and metal cover of your MICRO/CPU 100. Move the Voltage switch to the correct position (120 volts or 240 volts). In the 120 volt position, your tuner will function properly with a power supply voltage of 90 to 135 volts. In the 240 volt position, your tuner will function properly with a power supply voltage of 200 to 260 volts.

NORMAL FM DEEMPHASIS SWITCH: Use this switch inside the tuner only if you move to an area where the standard FM deemphasis characteristic is different. It is adjusted to the correct deemphasis of your area at Sherwood prior to shipment, so there is normally no need to touch it. The correct normal deemphasis is 75µsec. for the U.S. and 50µsec. for Europe and Japan.

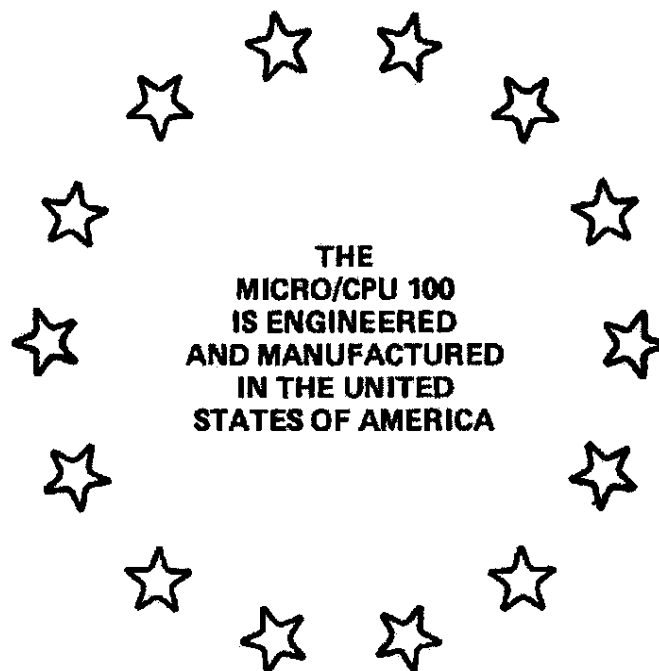

PHASE LOCKED LOOP DIGITAL FREQUENCY SYNTHESIZER

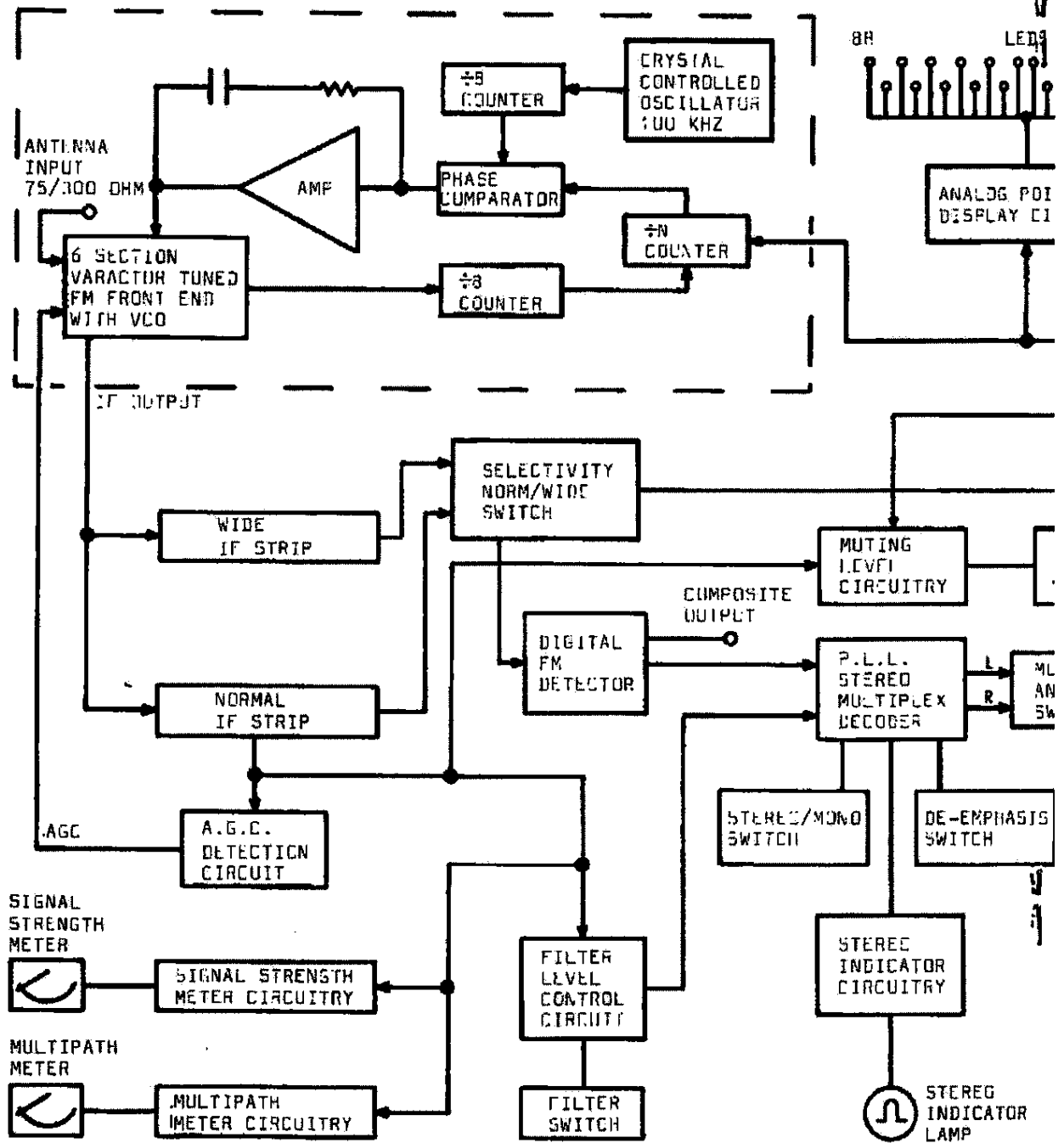

MICRO/CPU 101
BLOCK DIAG

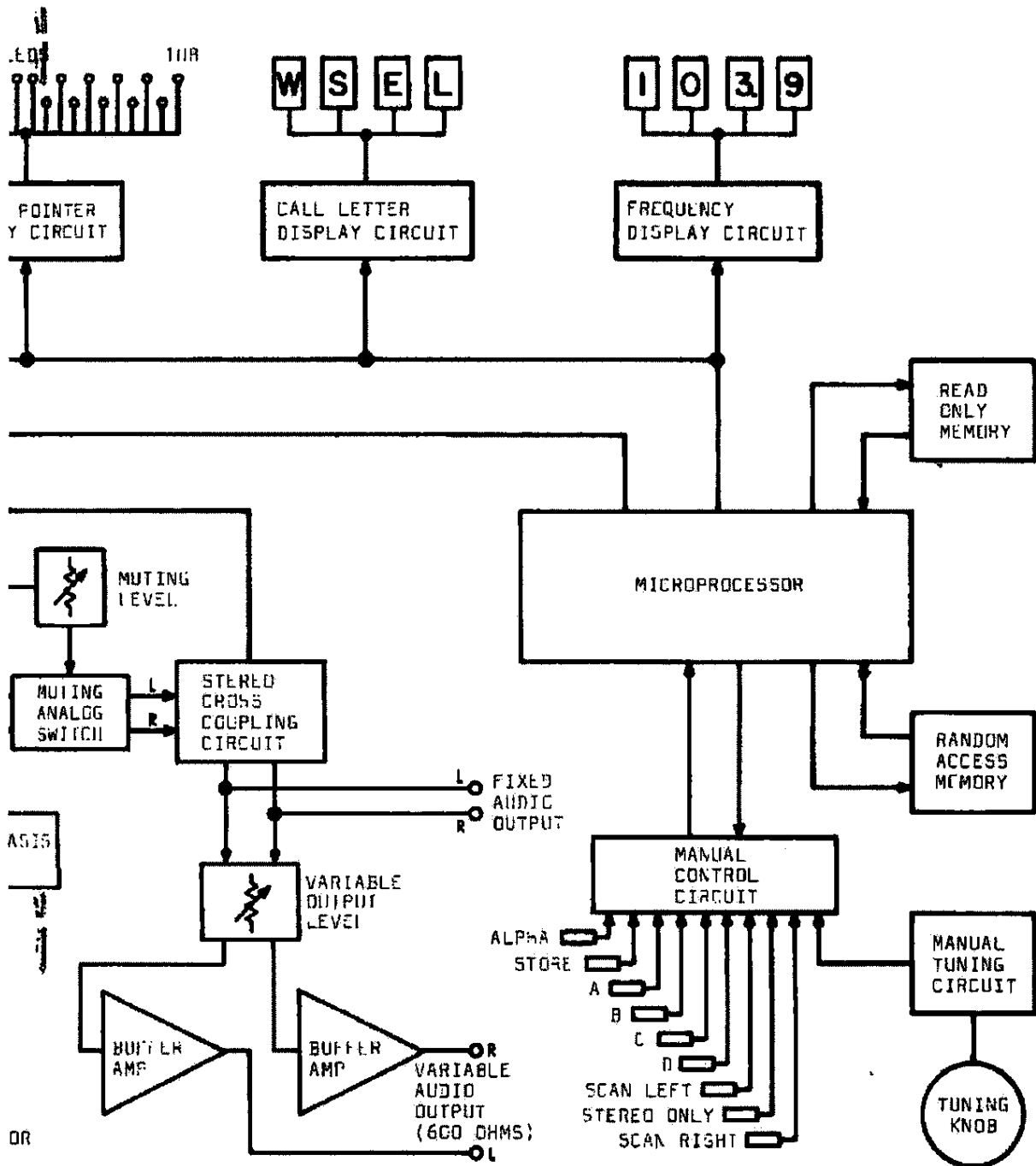

U 100 TUNER
DIAGRAM

Specifications:*

FM TUNER:

SELECTABLE TUNING RANGE:

Odd: 87.5-108.5 MHz (Domestic)

Even: 87.6-108.6 MHz (European)

TUNING ERROR: Less than .0024%

TUNING TYPE: Phase locked loop frequency synthesis micro computer locked tuning.

TUNING MODES:

Auto-Scan Left

Auto-Scan Right

Auto-Scan Stereo Only

4-Station Memory

(Auto-Scan and Memory controls are touch activated.)

READOUTS:

LED Analog Dial Pointer

LED 4-Character Frequency Display

LED 4-Character Alpha Numeric Station Identification Display

SIGNAL INDICATORS:

Signal Strength meter

Multipath meter

ANTENNA INPUTS:

300 ohm balanced

75 ohm unbalanced

| | IF NORMAL | IF WIDE |
|--|--------------------------|-------------------------|
| IHF SENSITIVITY: | 9.84dBf (1.7 μ V) | 9.84dBf 1.7 μ V) |
| 50dB QUIETING SENSITIVITY | 11.7dBf (2.1 μ V) | 13.5dBf 30 μ V) |
| STEREO SENSITIVITY (50dB S/N): | 25 μ V | 30 μ V |
| TOTAL HARMONIC DISTORTION (THD): | | |
| Mono: @100Hz: | 0.1% | .07% |
| @1000Hz: | 0.1% | .07% |
| @6000Hz: | .15% | 0.1% |
| Stereo: @100Hz: | 0.2% | .15% |
| @1000Hz: | 0.2% | .15% |
| @6000Hz: | .25% | .15% |
| SIGNAL TO NOISE RATIO: | | |
| Mono: | 75dB | 75dB |
| Stereo: | 72dB | 72dB |
| CAPTURE RATIO: | 1.0dB | 0.5dB |
| ALTERNATE-CHANNEL SELECTIVITY (IHF) | 80dB | 18dB |
| STEREO SEPARATION: | | |
| @ 100Hz: | 40dB | 45dB |
| @ 1000Hz: | 45dB | 50dB |
| @ 10KHz: | 35dB | 40dB |
| @30-15KHz: | 30dB | 35dB |
| SPURIOUS RESPONSE REJECTION: | 130dB | |

**All specifications with 120 VAC line; specifications and design subject to possible modification without notice.*

Specifications (continued)

TUNER (continued):

IMAGE REJECTION: 130dB

IF REJECTION: Greater than 120dB

MUTING THRESHOLD:

Front panel adjustable 3-1000 μ V

STEREO THRESHOLD: 4 μ V

NOISE FILTER OPERATING THRESHOLD: 25 μ V

FREQUENCY RESPONSE STEREO AND

MONO: 20-15000Hz \pm 0.5dB

19KHz REJECTION: Greater than 80dB

38KHz REJECTION: Greater than 80dB

OUTPUT VOLTAGE (AND IMPEDANCE) @100% MODULATION STEREO AND MONO:

Fixed: 1V (2200 ohms)

Variable: 0-1.5V (600 ohms)

GENERAL:

SEMICONDUCTORS:

76 ICs [8-bit CMOS microprocessor, 768x8 bit Read Only Memory (ROM), 256x8 Random Access Memory (RAM), and 1 ASCII character generator]; 48 transistors; 3 J-FETs; 3 MOS-FETs; 31 LEDs; 4 LED alpha numeric displays; 4 LED numeric displays; 6 varactor diodes; 31 signal diodes; 7 power diodes; 2 solid state infra-red interruptors.

POWER REQUIREMENTS:

Domestic: 120VAC, 50/60 Hz

Export: 240VAC, 50/60 Hz

POWER FUSE:

Domestic: $\frac{1}{2}$ A, 3AG (Slo-Blo type)

Export: $\frac{1}{4}$ A, 3AG (Slo-Blo type)

RATED POWER CONSUMPTION (DOMESTIC AND EXPORT): 30 watts

AC OUTLET: 500 watts unswitched

SHIPPING WEIGHT: 17.9 kg/39 $\frac{1}{2}$ lbs.

TUNER DIMENSIONS:

508(W), 162(H), 379(D) mm

20(W), 6-3/8(H), 14-15/16(D) inches

TUNER WEIGHT: 15.4 kg/34 lbs.

FURNISHED ACCESSORIES:

2 Shielded Audio Cables

1 FM Dipole Antenna

1 Installation and Operation Manual

Typical Performance Curves

TUNER

FM SIGNAL/NOISE RATIO VS ANTENNA INPUT

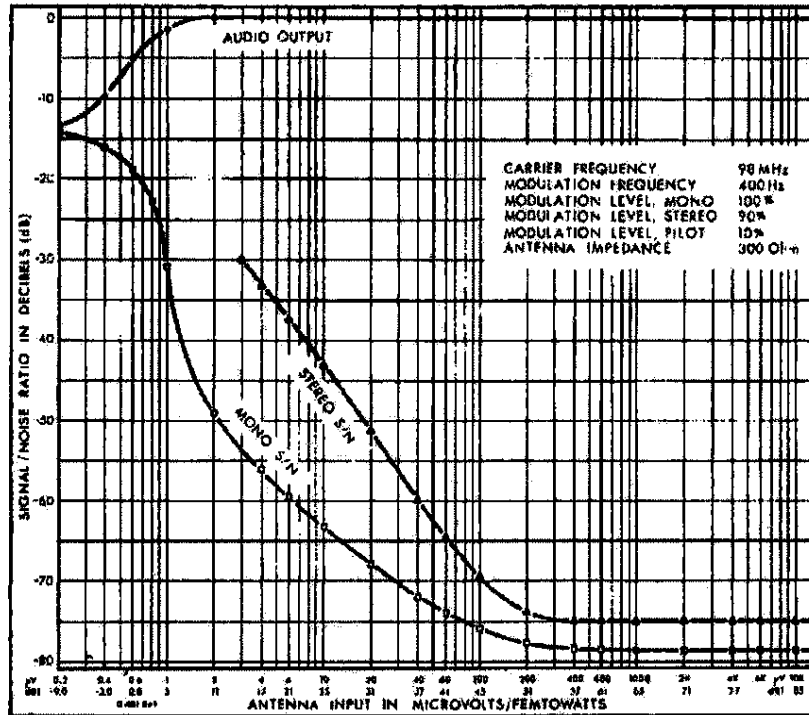

TOTAL HARMONIC DISTORTION VS ANTENNA INPUT

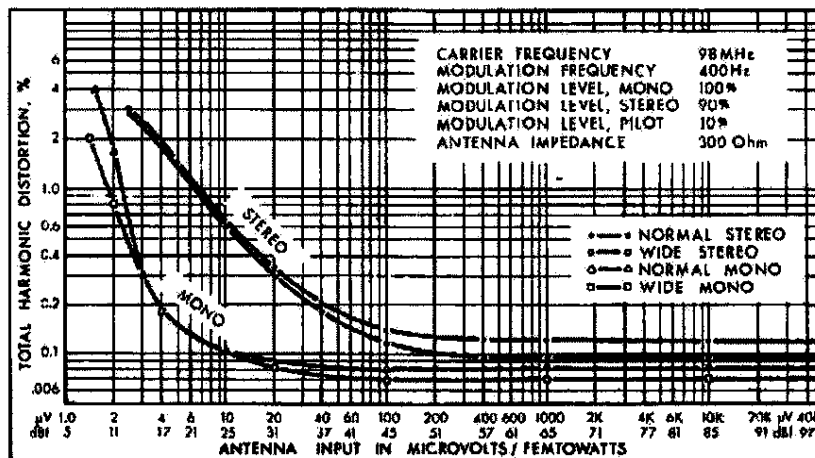

TUNER (CONTINUED)

FM FREQUENCY RESPONSE & SEPARATION VS FREQUENCY

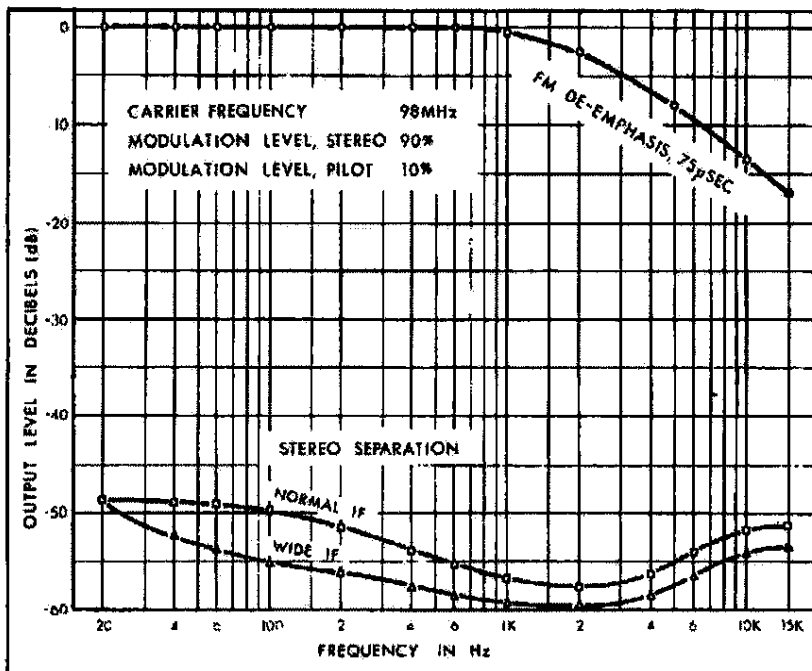

ANTENNA INPUT VS METER DEFECTION

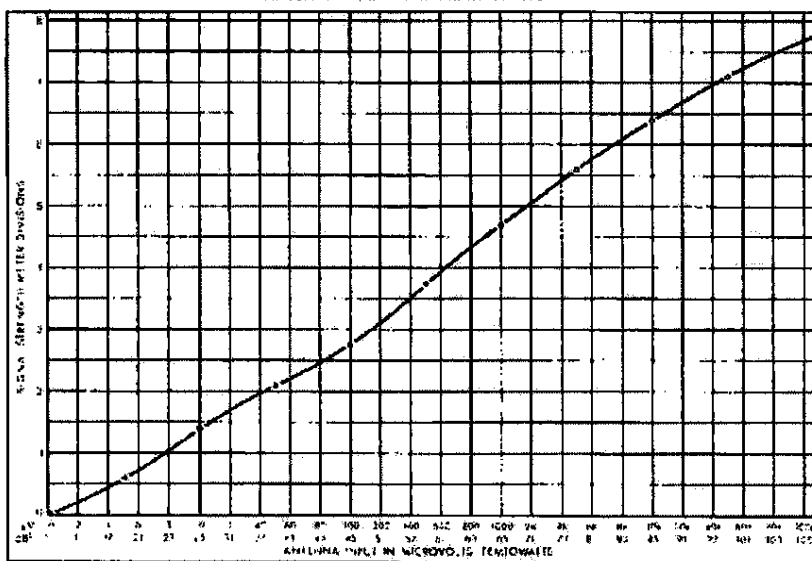

TUNER (CONTINUED)

FM IF BANDWIDTH VS FREQUENCY

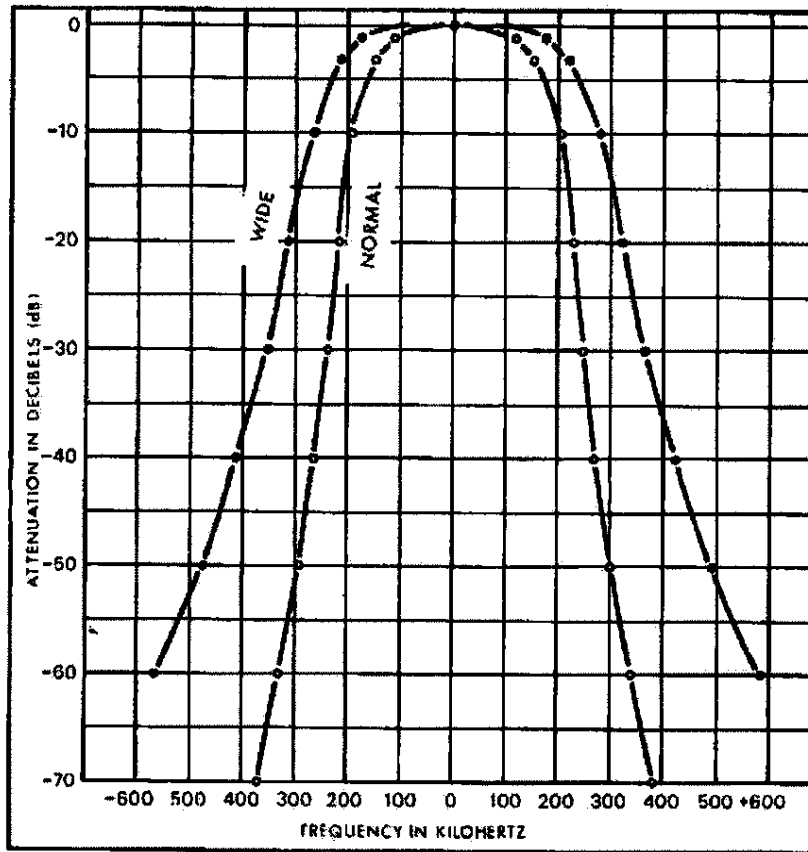

Common Installation Problems

Although your MICRO/CPU 100 is simple to operate, there are a variety of common problems which may occur. If after connection to your system the tuner does not seem to be working properly, go back and reread this manual to make sure you have accurately set all controls.

RECHECK ALL CONNECTIONS: Also check the other components in your system for proper operation according to their instruction manuals.

| PROBLEM: | PROBABLE CAUSE: |
|--|---|
| No output from either channel (no front panel LEDs are illuminated). | AC power cord accidentally disconnected or no power at AC wall outlet; Main fuse on back panel blown (open). |
| No output from either channel (some front panel LEDs are illuminated). | Speaker Selector switch incorrectly positioned on amplifier; Power Amp/Preamp Mode switch on the amplifier in the wrong position; A Tape Monitor or 4-Channel Adaptor switch on the amplifier may be accidentally depressed; Tuner output cables incorrectly connected to the amplifier. |
| Output from one channel only. | Balance control on the amplifier accidentally moved to an extreme Left or Right position; Input properly connected to one channel (possibly a shorted or open cable) between the amplifier and the MICRO/CPU 100. |
| Extreme hum, noise or distortion. | In some cases, reversing the AC plug on the line cord will eliminate a hum problem. Check for loose connections. Reread this manual to verify all hookup instructions have been accurately followed. |
| Continuous or intermittent noise like 'zzzzzz.' | Fluorescent lamp, motor, or lamp dimmer being used in the vicinity of the tuner. NOTE: In many cases it is difficult to remove the source of noise; however, increasing the input signal by using an outdoor antenna may alleviate this problem. |
| Static noise (in particular, when automobiles run close to the house). | Insufficient FM input signal; using an outdoor antenna may reduce or eliminate this type of problem. |

Notes

CLEANING THE FRONT PANEL AND ACRYLIC GLASS: Use of household or industrial cleaning agents (or any cloth that has been used to apply same) may damage or remove printing on the panel or glass. To remove dust or other atmospheric contamination use a soft, freshly laundered cloth moistened with plain lukewarm water, and gently wipe until clean.



is a trademark
of Sherwood Electronic Laboratories, Inc.

"MICRO/CPU" and Memory Match" are
trademarks of Draco Laboratories, Inc., USA.

WARRANTY INFORMATION

The warranty covering your Sherwood solid state high fidelity unit is packed with the component when shipped. Please attach the aforementioned statement to this page for a permanent record of your warranty coverage.

If your Sherwood component is not operating satisfactorily after purchase, contact your Sherwood dealer, who may be authorized to repair or refer you to the most conveniently located Sherwood Service Station. A current list of Authorized Service Stations is available upon request from Sherwood.

Sherwood reserves the right to change or improve its products without obligation to modify units previously manufactured.



TM

SHERWOOD

We have reserved this space for the attachment of your sales receipt and the customer portion of the warranty card so that you may have a permanent record of the serial number, date of purchase, and dealer's name.



SHERWOOD ELECTRONIC LABORATORIES, INC.
4300 NORTH CALIFORNIA AVENUE, CHICAGO, ILLINOIS 60618